

PAC5232/PAC5232A

Data Sheet

Power Application Controller®

Multi-Mode Power Manager™
Configurable Analog Front End™
Application Specific Power Drivers™
Arm® Cortex®-M0 Controller Core



TABLE OF CONTENTS

1	GENERAL DESCRIPTION	8
2	PAC® FAMILY APPLICATIONS.....	9
3	PRODUCT SELECTION SUMMARY	10
4	ORDERING INFORMATION.....	10
5	FEATURES	11
5.1	Feature Overview	11
6	ABSOLUTE MAXIMUM RATINGS.....	12
7	ARCHITECTURAL BLOCK DIAGRAM.....	13
8	PIN CONFIGURATION.....	14
8.1	PAC5232QX Pin Configuration (51L SLP 8x8 mm Package).....	14
9	PIN DESCRIPTION.....	15
9.1	Power and Ground Pin Description.....	15
9.2	Signal Manager Pin Description.....	15
9.3	Driver Manager Pin Description	16
9.4	I/O Ports Pin Description.....	17
10	CONFIGURABLE POWER MANAGER (CPM)	19
10.1	Features	19
10.2	Functional Description.....	19
10.3	High-Voltage Supply Controller (HV-BUCK).....	20
10.3.1	HV-BUCK Re-start Handling	21
10.4	Medium-Voltage Buck Regulator (MV-BUCK)	21
10.5	Linear Regulators	21
10.6	Power-up Sequence.....	22
10.7	Hibernate Mode.....	23
10.8	Power and Temperature Monitor	23
10.9	Voltage Reference	24
10.10	Electrical Characteristics.....	25
10.11	Typical Performance Characteristics	28
11	CONFIGURABLE ANALOG FRONT END (CAFE).....	29
11.1	Features	29
11.2	Block Diagram	30
11.3	Functional Description.....	31
11.4	Differential Programmable Gain Amplifier (DA)	31

11.5	Single-Ended Programmable Gain Amplifier (AMP).....	31
11.6	General Purpose Comparator (CMP).....	31
11.7	Phase Comparator (PHC).....	31
11.8	Protection Comparator (PCMP).....	32
11.9	Analog Output Buffer (BUF).....	32
11.10	Analog Front End I/O (AIO).....	32
11.11	Push Button (PBTN).....	32
11.12	HP DAC and LP DAC.....	33
11.13	ADC Pre-Multiplexer	33
11.14	Configurable Analog Signal Matrix (CASM).....	33
11.15	Configurable Digital Signal Matrix (CDSM).....	33
11.16	Low-Frequency Clock Output.....	33
11.17	Cycle-by-cycle Current Limit	34
11.18	Temperature Protection	34
11.19	Electrical Characteristics.....	35
12	APPLICATION SPECIFIC POWER DRIVERS (ASPD).....	39
12.1	Features	39
12.2	Block Diagram	39
12.3	Functional Description.....	39
12.4	Low-Side Gate Driver	40
12.5	High-Side Gate Driver	40
12.6	Power Drivers Control	41
12.7	Gate Driver Fault Protection.....	41
12.8	Electrical Characteristics.....	42
13	ADC WITH AUTO-SAMPLING SEQUENCER.....	43
13.1	ADC Block Diagram	43
13.2	Functional Description.....	43
13.2.1	ADC.....	43
13.2.2	Auto-Sampling Sequencer	44
13.2.3	EMUX Control	44
13.3	Electrical Characteristics.....	45
14	MEMORY SYSTEM	46
14.1	Features	46
14.2	Memory System Block Diagram.....	46

14.3	Functional Description.....	46
14.4	Program FLASH.....	46
14.5	INFO FLASH.....	46
14.6	SRAM.....	47
14.7	SWD Protection.....	47
14.8	Electrical Characteristics.....	47
15	SYSTEM AND CLOCK CONTROL.....	48
15.1	Features.....	48
15.2	Block Diagram.....	48
15.3	Functional Description.....	49
15.3.1	Free-Running Clock (FRCLK).....	49
15.3.2	Auxiliary Clock (ACLK).....	49
15.3.3	Clock Gating.....	49
15.3.4	Ring Oscillator (ROSC).....	49
15.3.5	Trimmed 4MHz RC Oscillator.....	49
15.3.6	External Clock Input.....	49
15.3.7	PLL.....	49
15.4	Electrical Characteristics.....	50
16	ARM CORTEX®-M0 MCU CORE.....	51
16.1	Features.....	51
16.2	Block Diagram.....	51
16.3	Functional Description.....	51
16.4	Electrical Characteristics.....	52
16.5	Typical Performance Characteristics.....	52
17	IO CONTROLLER.....	53
17.1	Features.....	53
17.2	Block Diagram.....	53
17.3	Functional Description.....	54
17.4	GPIO Current Injection.....	54
17.5	Electrical Characteristics.....	55
18	SERIAL INTERFACE.....	56
18.1	Block Diagram.....	56
18.2	Functional Description.....	57
18.3	I ² C Controller.....	57

18.4	UART Controller	57
18.5	SPI Controller	57
18.6	Dynamic Characteristics	58
19	TIMERS	62
19.1	Block Diagram	62
19.2	Functional Description	63
19.2.1	Timer A	63
19.2.2	Timer B	64
19.2.3	Timer C	64
19.2.4	Timer D	64
19.2.5	Watchdog Timer	64
19.2.6	SOC Bus Watchdog Timer	64
19.2.7	Wake-Up Timer	64
19.2.8	Real-Time Clock	64
20	THERMAL CHARACTERISTICS	65
21	APPLICATION EXAMPLES	66
22	PACKAGE OUTLINE AND DIMENSIONS	67
22.1	51L 8x8 QFN Package Outline and Dimensions	67

LIST OF TABLES

Table 10-1 High-Voltage Buck Controller Electrical Characteristics.....	25
Table 10-2 Medium-Voltage Buck Controller Electrical Characteristics	26
Table 10-3 Linear Regulators Electrical Characteristics	27
Table 11-1 Differential Programmable Gain Amplifier (DA) Electrical Characteristics (AIO<5:0>)	35
Table 11-2 Single-Ended Programmable Gain Amplifier (AMP) Electrical Characteristics (AIO<9:6>).....	36
Table 11-3 General Purpose Comparator (CMP) Electrical Characteristics (AIO<9:6>)	36
Table 11-4 Phase Comparator (PHC) Electrical Characteristics (AIO<9:6>)	36
Table 11-5 Special Mode Electrical Characteristics (AIO<9:7>).....	37
Table 11-6 Special Mode Electrical Characteristics (AIO6).....	37
Table 11-7 Analog Front End (AIO) Electrical Characteristics (AIO<9:0>).....	37
Table 11-8 Push Button (PBTN) Electrical Characteristics (AIO6).....	38
Table 11-9 HP DAC and LP DAC Electrical Characteristics.....	38
Table 11-10 Low-Frequency Clock Output (CLKOUT)	38
Table 11-11 Temperature Protection	38
Table 12-1 Power Driver Resources by Part Numbers.....	40
Table 12-2 Microcontroller Port and PWM to Power Driver Mapping.....	41
Table 12-3 Power Driver Propagation Delay	41
Table 12-4 Gate Driver Electrical Characteristics	42
Table 13-1 ADC and Sequencer Electrical Characteristics	45
Table 14-1 Memory System Electrical Characteristics	47
Table 15-1 CCS Electrical Characteristics.....	50
Table 16-1 MCU and Clock Control System Electrical Characteristics	52
Table 17-1 IO Controller Electrical Characteristics	55
Table 18-1 Serial Interface Dynamic Characteristics.....	58
Table 18-2 I ² C Dynamic Characteristics	59
Table 18-3 SPI Dynamic Characteristics	61
Table 20-1 Thermal Characteristics.....	65

LIST OF FIGURES

Figure 10-1 CPM Block Diagram	19
Figure 10-2 HV-BUCK Example	20
Figure 10-3 MV-BUCK Switching Regulator Example	21
Figure 10-4 Linear Regulators Example	22
Figure 10-5 Power-Up Sequence	22
Figure 10-6 VDDIO LDO Voltage vs. Current	28
Figure 10-7 VCC33 LDO Voltage vs. Current	28
Figure 10-8 VCORE LDO Voltage vs. Current	28
Figure 11-1 Configurable Analog Front End	30
Figure 12-1 Application Specific Power Drivers	39
Figure 12-2 Typical Gate Driver Connections	40
Figure 13-1 ADC with Auto-Sampling Sequencer	43
Figure 14-1 Memory System	46
Figure 15-1 Clock Control System	48
Figure 16-1 Arm® Cortex®-M0 Microcontroller Core	51
Figure 16-2 MCU Performance Characteristics	52
Figure 17-1 IO Controller Block Diagram	53
Figure 18-1 Serial Interface Block Diagram	56
Figure 18-2 I ² C Timing Diagram	60
Figure 18-3 SPI Timing Diagram	61
Figure 19-1 PWM Timers Block Diagram	62
Figure 19-2 SOC Bus Watchdog and Wake-Up Timer	63
Figure 19-3 Real-Time Clock and Watchdog Timer	63
Figure 21-1 3-Phase Motor Using PAC5232 (Simplified Diagram)	66

1 GENERAL DESCRIPTION

The PAC5232 is a Power Application Controller® (PAC) product that is optimized for high-speed motor control and driving. The PAC5232 integrates a 50MHz Arm® Cortex®-M0 32-bit microcontroller core with a highly-configurable Power manager, Active-Semi's proprietary and patent-pending Configurable Analog Front-End™ and Application Specific Power Drivers™ to form the most compact microcontroller-based power and motor control solution available.

The PAC5232 microcontroller features 32kB of embedded FLASH and 8kB of SRAM memory, a 1MSPS analog-to-digital converter (ADC) with programmable auto-sequencer, 3.3V/5V IO, flexible clock control system, PWM and general-purpose timers and several serial communications interfaces.

The Configurable Power Manager (CPM) provides “all-in-one” efficient power management solution for multiple types of power sources. It features a configurable high-voltage switching supply controller capable of operating a buck converter, a configurable medium-voltage switching regulator, and four linear regulated voltage supplies. The Application Specific Power Drivers (ASPD) are 180V power drivers designed for half bridge, H-bridge, 3-phase, and general purpose driving. The Configurable Analog Front End (CAFE) comprises differential programmable gain amplifiers, single-ended programmable gain amplifiers, comparators, digital-to-analog converters, and I/Os for programmable and inter-connectible signal sampling, feedback amplification, and sensor monitoring of multiple analog input signals.

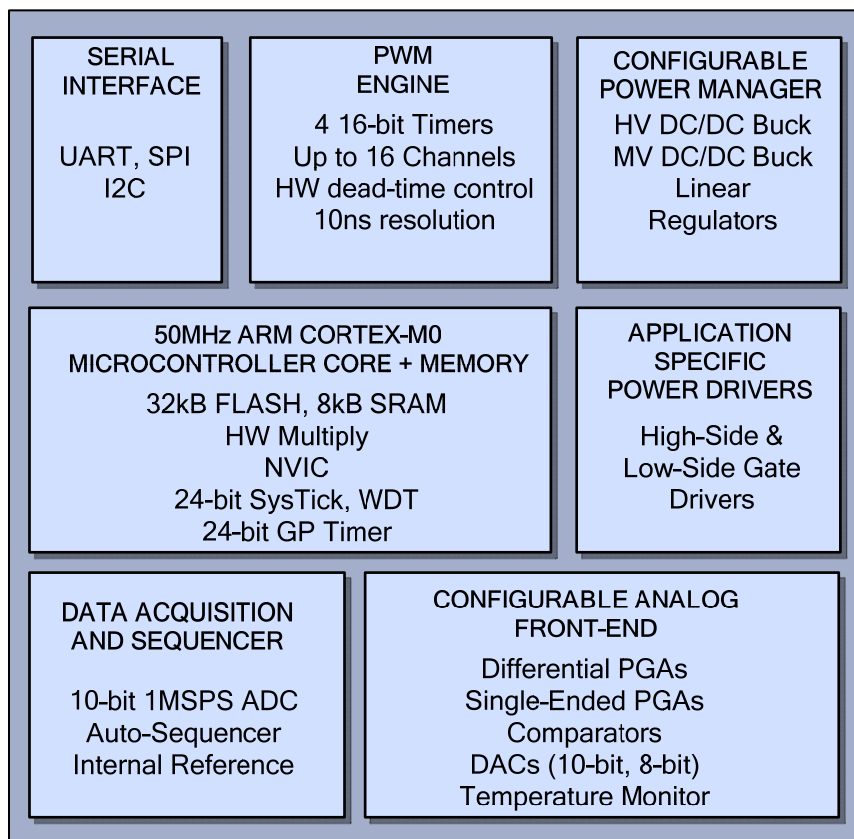

The PAC5232 is available in a 51-pin, 8x8mm TQFN package.

2 PAC® FAMILY APPLICATIONS

- Garden Tools
- Telecom Fans
- Light Electric Vehicle
- Battery Powered Motor Controllers and Drivers from 48VC – 120VDC

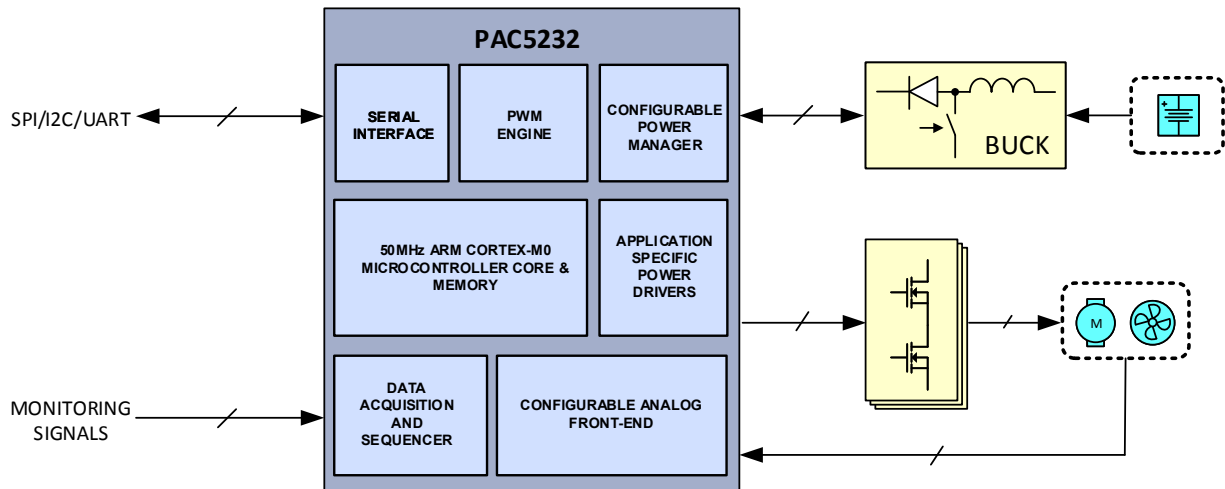

3 PRODUCT SELECTION SUMMARY

PART NUMBER	PIN PKG	POWER MANAGER		CONFIGURABLE ANALOG FRONT END					APPLICATION SPECIFIC POWER DRIVERS			MCU					APPLICATION
		INPUT VOLTAGE	DC/DC	DIFF-PGA	PGA	COMPARATOR	DAC	ADC CHANNEL	VBST/VSRC	POWER DRIVER	PWM CHANNEL	SPEED (MHz)	FLASH (kB)	SRAM (kB)	GPIO	SERIAL COMM	
PAC5232 PAC5232A	51L 8x8 QFN	25V- 160V	Y	3	4	10	2	9	180V	3 LS (2A) 3 HS (2A)	6@VP 6@VCCIO	50	32	8	29	UART SPI I2C SWD	3 half-bridge 3 phase control BEMF Trapezoidal or FOC

Notes: DIFF-PGA = differential programmable gain amplifier; HS = high-side, LS = low-side, PGA = programmable gain amplifier, VSRC = Bootstrap Voltage Source

4 ORDERING INFORMATION

PART NUMBER	TEMPERATURE RANGE	PACKAGE	PINS	PACKING
PAC5232QX PAC5232AQX	-40°C to 105°C	51L 8x8 QFN	51 + Exposed Pad	Tray

5 FEATURES

5.1 Feature Overview

- **Configurable Power Manager**
 - High-voltage buck switching supply controller
 - Input Voltage: 25V – 160V
 - Configurable Output Voltage: 12V or 15V
 - 5V medium-voltage switching supply regulator
 - 3 Linear regulators with power and hibernate management
 - Power and temperature monitor, warning, fault detection
- **Proprietary Configurable Analog Front-End**
 - 10 Analog Front-End IO pins
 - 3 Differential Programmable Gain Amplifiers
 - 4 Single-ended Programmable Gain Amplifiers
 - Programmable Over-Current Protection
 - 10 Comparators
 - 2 10-bit DACs
- **Proprietary Application Specific Power Drivers**
 - 3 180V high-side gate drivers with 2A gate driving capability
 - 3 low-side gate drivers with 2A gate driving capability
 - Configurable propagation delay and fault protection
- **3.3V I/Os**
 - 2 general-purpose I/Os with tri-state and dedicated analog input to ADC
- **True 5V I/Os**
 - 11 general-purpose I/Os with tri-state, pull-up, pull-down and dedicated I/O supply
 - Configurable as true 5V or 3.3V I/Os
- **50MHz Arm® Cortex®-M0 32-bit Microcontroller Core**
 - Single-cycle 32-bit x 32-bit hardware multiplier
 - Integrated sleep and deep sleep modes
 - Nested Vectored Interrupt Controller (NVIC) with 20 Interrupts with 3 levels of priority
 - 24-Bit SysTick Timer
 - Wake-up Interrupt Controller (WIC) allowing power-saving sleep modes
 - Clock-gating allowing low-power operation
- **Memory**
 - 32kB FLASH
 - 8kB SRAM
- **Analog to Digital Converter (ADC)**
 - 10-bit resolution
 - 1MSPS
 - Dual Programmable ADC Auto-Sequencers
- **Flexible clock and PLL from internal 1.25% oscillator, ring oscillator, external clock or crystal**
- **9 Timing Generators**
 - Four 16-bit timers with up to 16 PWM/CC blocks and 7 independent dead-time controllers
 - 24-bit watchdog timer
 - 4s or 8s watchdog timer
 - 24-bit real time clock
 - 24-bit SysTick timer
 - Wake-up timer for sleep modes from 0.125s to 8s
- **SPI, I2C, and UART serial communication interfaces**
- **SWD debug interface with interface disable function**

6 ABSOLUTE MAXIMUM RATINGS

The table below shows the absolute maximum ratings for this device.

To prevent damage to the device, do not exceed these limits. Exposure to the absolute maximum rating conditions for long periods of time may affect device reliability.

The device is not guaranteed to function properly outside of the operating conditions.

PARAMETER	VALUE	UNIT	
VM to VSS	-0.3 to 160	V	
BST to VSS	-0.3 to 180	V	
BST to SRC	-0.3 to 20	V	
SRC to VSS	-10 to VM + 15	V	
DRM to SRC	-0.3 to BST + 0.3	V	
VP to VSS	-0.3 to 20	V	
SW to VSS	-0.3 to V _P + 0.3	V	
CSM to VP	-0.3 to 0.3	V	
VSYS to VSS	-0.3 to 6	V	
AIO<9:7>, AIO<5:0>, VCCIO, AIO6 to VSS	-0.3 to V _{SYS} + 0.3	V	
PD<x>, PE<x> to VSS	-0.3 to V _{CCIO} + 0.3	V	
PC<x> to VSS	-0.3 to V _{CC33} + 0.3	V	
PA<x>, PB<x>, PC<x>, PD<x>, PE<x> pin injection current	7.5	mA	
PA<x>, PB<x>, PC<x>, PD<x>, PE<x> sum of all pin injection current	25	mA	
VCC33 to VSS	-0.3 to 4.1	V	
VCORE to VSS	-0.3 to 2.5	V	
DRL0, DRL1, DRL2 to VSS	-0.3 to V _P + 0.3	V	
DRB3, DRB4, DRB5 to VSS	-0.3 to 180	V	
DRS3, DRS4, DRS5 to VSS	-10 to VM + 15	V	
DRB3 to DRS3, DRB4 to DRS4, DRB5 to DRS5	-0.3 to 20	V	
DRH3 to DRS3, DRH4 to DRS4, DRH5 to DRS5	-0.3 to V _{DRBx} + 0.3	V	
VSS RMS Current ¹	0.2	A _{RMS}	
Operating temperature range	-40 to 105	°C	
Electrostatic Discharge (ESD)	Human body model (JEDEC)	2	kV
	Charge device model (JEDEC)	1	kV

¹ Peak current may be 10 times higher than the RMS value for pulses shorter than 10µs.

7 ARCHITECTURAL BLOCK DIAGRAM

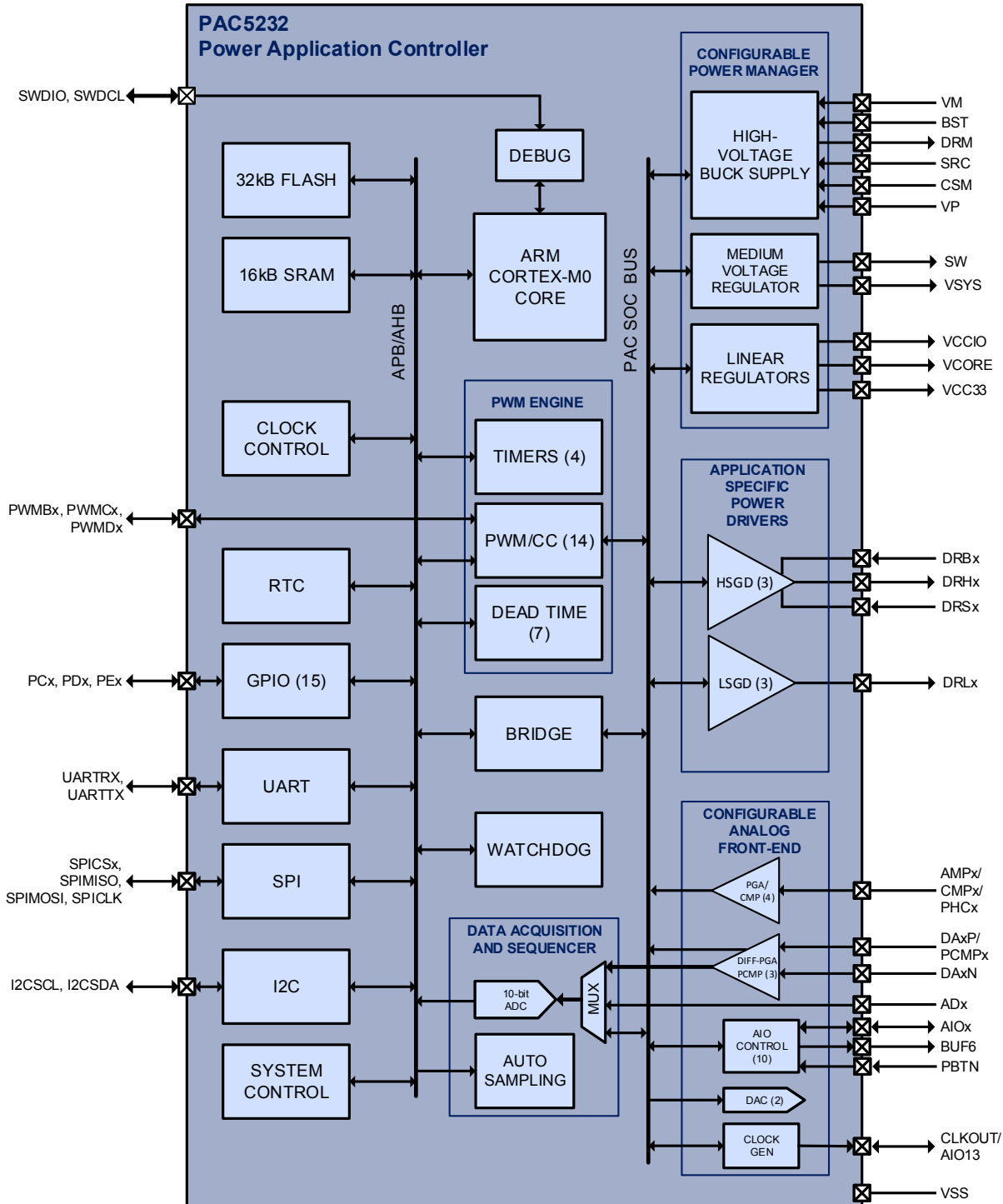

8 PIN CONFIGURATION

8.1 PAC5232QX Pin Configuration (51L SLP 8x8 mm Package)

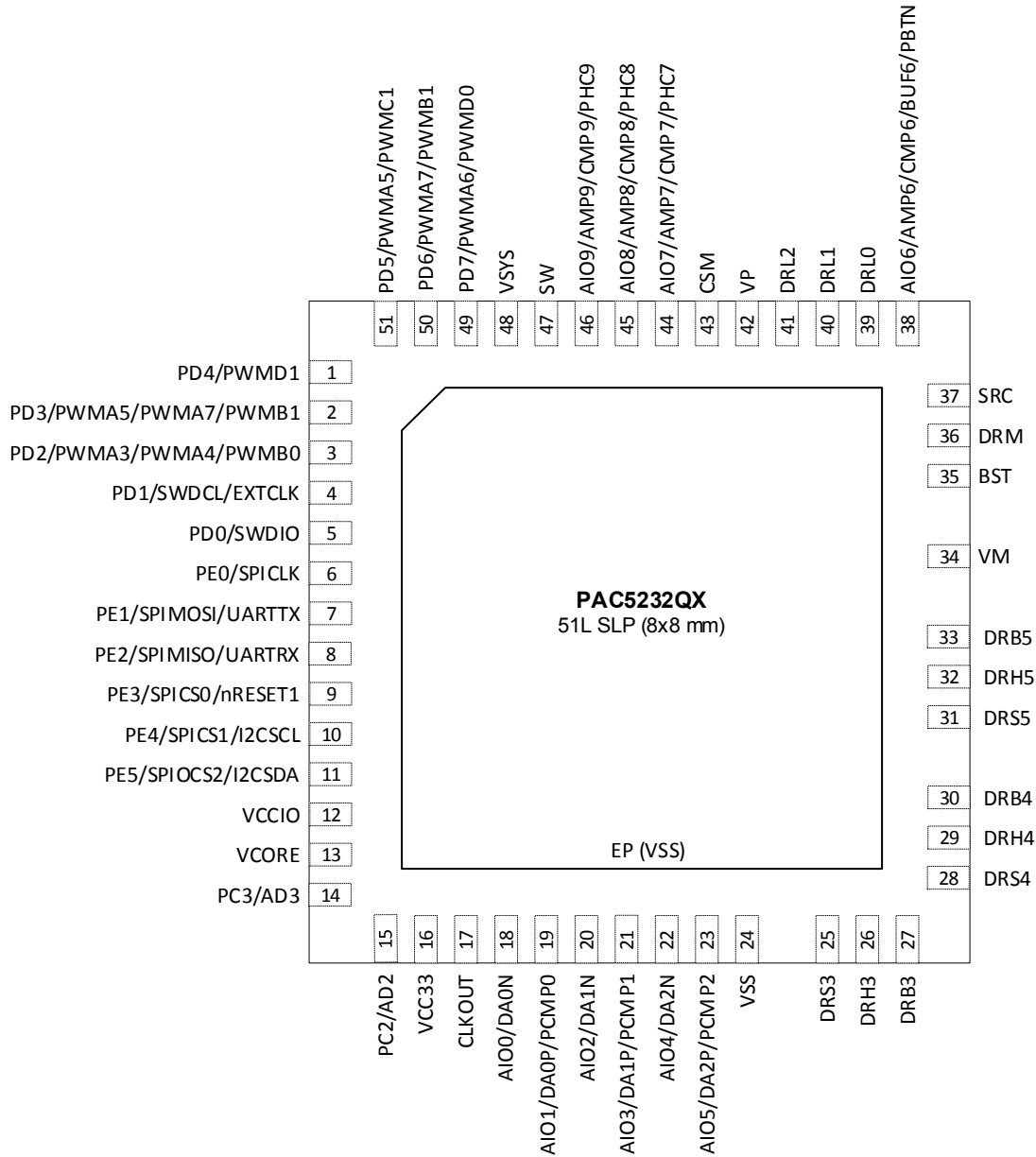

9 PIN DESCRIPTION

9.1 Power and Ground Pin Description

PIN NAME	PIN NUMBER	TYPE	DESCRIPTION
VCCIO	12	Power	Internally generated digital I/O 3.3V power supply. Connect a 2.2μF or higher value ceramic capacitor from V _{CCIO} to V _{SSA} .
VCORE	13	Power	Internally generated digital I/O 1.8V power supply. Connect a 2.2μF or higher value ceramic capacitor from V _{CC18} to V _{SSA} .
VCC33	16	Power	Internally generated 3.3V power supply. Connect to a 2.2μF or higher value ceramic capacitor from V _{CC33} to V _{SSA} .
VSS	24	Power	Ground.
VM	34	Power	High-Voltage Buck Regulator supply controller input. Connect a high value electrolytic capacitor in parallel with a 0.1μF ceramic capacitor from VM to VSS. This pin requires good capacitive bypass to V _{SS} , so the ceramic capacitor must be connected with a shorter than 10mm trace from the pin.
BST	35	Power	High-Voltage Buck Regulator bootstrap input. Connect a 2.2μF or higher value ceramic capacitor from BST to SRC with a shorter than 10mm trace from the pin.
DRM	36	Power	High-Voltage Buck Regulator Switching supply driver output. Connect to the gate of the external power N-channel MOSFET.
SRC	37	Power	High-Voltage Buck Regulator Source. Connect to the source of the high-side power MOSFET of the high-voltage buck regulator.
VP	42	Power	Main power supply. Provides power to the power drivers as well as voltage feedback path for the switching supply. Connect a properly sized supply bypass capacitor in parallel with a 10μF ceramic capacitor in parallel with a 100μF aluminum capacitor from V _P to V _{SS} for voltage loop stabilization. If the switching frequency of the HV-BUCK is >= 200kHz, then the 100μF aluminum capacitor can be replaced with 47μF, but the efficiency will be worse. This pin requires good capacitive bypassing to V _{SS} , so the ceramic capacitor must be connected with a shorter than 10mm trace from the pin.
CSM	43	Power	High-Voltage Buck Regulator Switching supply current sense input. Connect to the positive side of the current sense resistor.
SW	47	Power	Switch node for the medium-voltage buck regulator.
VSYS	48	Power	5V System power supply. Connect to a 22μF/6.3V (20%) or higher ceramic capacitor from V _{SYS} to V _{SS} .
EP (VSS)	EP	Power	Exposed pad. Must be connected to V _{SS} in a star ground configuration. Connect to a large PCB copper area for power dissipation heat sinking.

9.2 Signal Manager Pin Description

PIN NAME	PIN NUMBER	FUNCTION	TYPE	DESCRIPTION
CLKOUT	17	CLKOUT	I/O	Low-frequency clock reference output (250Hz – 2kHz), or GPIO.
AIO0	18	AIO0	I/O	Analog front end I/O 0.
		DA0N	Analog	Differential PGA 0 negative input.
AIO1	19	AIO1	I/O	Analog front end I/O 1.
		DA0P	Analog	Differential PGA 0 positive input.
AIO2	20	AIO2	I/O	Analog front end I/O 2.
		DA1N	Analog	Differential PGA 1 negative input.

AIO3	21	AIO3	I/O	Analog front end I/O 3.
		DA1P	Analog	Differential PGA 1 positive input.
AIO4	22	AIO4	I/O	Analog front end I/O 4.
		DA2N	Analog	Differential PGA 2 negative input.
AIO5	23	AIO5	I/O	Analog front end I/O 5.
		DA2P	Analog	Differential PGA 2 positive input.
AIO6	38	AIO6	I/O	Analog front end I/O 6.
		AMP6	Analog	PGA input 6.
		CMP6	Analog	Comparator input 6.
		BUF6	Analog	Buffer output 6.
		PBTN	Analog	Push button input.
AIO7	44	AIO7	I/O	Analog front end I/O 7.
		AMP7	Analog	PGA input 7.
		CMP7	Analog	Comparator input 7.
		PHC7	Analog	Phase comparator input 7.
AIO8	45	AIO8	I/O	Analog front end I/O 8.
		AMP8	Analog	PGA input 8.
		CMP8	Analog	Comparator input 8.
		PHC8	Analog	Phase comparator input 8.
AIO9	46	AIO9	I/O	Analog front end I/O 9.
		AMP9	Analog	PGA input 9.
		CMP9	Analog	Comparator input 9.
		PHC9	Analog	Phase comparator input 9.

9.3 Driver Manager Pin Description

PIN NAME	PIN NUMBER	TYPE	DESCRIPTION
DRS3	25	Analog	High-side gate driver source 3.
DRH3	26	Analog	High-side gate driver 3.
DRB3	27	Analog	High-side gate driver bootstrap 3. Connect a 1µF or higher value ceramic capacitor from DRB3 to DRS3 with a 10mm or shorter trace from the pin.
DRS4	28	Analog	High-side gate driver source 4.
DRH4	29	Analog	High-side gate driver 4.
DRB4	30	Analog	High-side gate driver bootstrap 4. Connect a 1µF or higher value ceramic capacitor from DRB4 to DRS4 with a 10mm or shorter trace from the pin.
DRS5	31	Analog	High-side gate driver source 5.
DRH5	32	Analog	High-side gate driver 5.
DRB5	33	Analog	High-side gate driver bootstrap 5. Connect a 1µF or higher value ceramic capacitor from DRB5 to DRS5 with a 10mm or shorter trace from the pin.
DRL0	39	Analog	Low-side gate driver 0.
DRL1	40	Analog	Low-side gate driver 1.
DRL2	41	Analog	Low-side gate driver 2.

9.4 I/O Ports Pin Description

PIN NAME	PIN NUMBER	FUNCTION	TYPE	DESCRIPTION ²
PD4	1	PD4	I/O	I/O port D4.
		PWMD1	I/O	Timer D PWM/capture 1.
PD3	2	PD3	I/O	I/O port D3.
		PWMA5	I/O	Timer A PWM/capture 5.
		PWMA7	I/O	Timer A PWM/capture 7.
		PWMB1	I/O	Timer B PWM/capture 1.
PD2	3	PD2	I/O	I/O port D2.
		PWMA3	I/O	Timer A PWM/capture 3.
		PWMA4	I/O	Timer A PWM/capture 4.
		PWMB0	I/O	Timer B PWM/capture 0.
PD1	4	PD1	I/O	I/O port D1.
		SWDCL	I	Serial wire debug clock.
		EXTCLK	I	External clock input.
PD0	5	PD0	I/O	I/O port D0.
		SWDIO	I/O	Serial wire debug I/O.
PE0	6	PE0	I/O	I/O port E0.
		SPICLK	I/O	SPI clock.
PE1	7	PE1	I/O	I/O port E1.
		SPIMOSI	I/O	SPI master out, slave in (MOSI)
		UARTTX	O	UART transmit output.
PE2	8	PE2	I/O	I/O port E2.
		SPI MISO	I/O	SPI master in, slave out (MISO)
		UARTRX	I	UART receive input.
PE3	9	PE3	I/O	I/O port E3.
		SPICS0	O	SPI chip select 0.
		nRESET1	I	Reset input 1.
PE4	10	PE4	I/O	I/O port E4.
		SPICS1	O	SPI chip select 1.
		I2CSCL	I/O	I2C clock
PE5	11	PE5	I/O	I/O port E5.
		SPICS2	O	SPI chip select 2.
		I2CSDA	I/O	I2C data.
PC3	14	PC3	I/O	I/O port C3.
		AD3	Analog	ADC input 3.
PC2	15	PC2	I/O	I/O port C2.
		AD2	Analog	ADC input 2.

² For a full description of all of the pin configurations for each digital I/O, see the PAC5232 User Guide for the Peripheral MUX.



PAC5232/PAC5232A Power Application Controller®

PD7	49	PD7	I/O	I/O port D7.
		PWMA6	I/O	Timer A PWM/capture 6.
		PWMD0	I/O	Timer D PWM/capture 0.
PD6	50	PD6	I/O	I/O port D6.
		PWMA7	I/O	Timer A PWM/capture 7.
		PWMB1	I/O	Timer B PWM/capture 1.
PD5	51	PD5	I/O	I/O port D5.
		PWMA5	I/O	Timer A PWM/capture 5.
		PWMC1	I/O	Timer C PWM/capture 1.

10 CONFIGURABLE POWER MANAGER (CPM)

10.1 Features

- 160V Buck DC/DC Controller (HV Buck)
 - 25V – 160V input
- 5V Switching Regulator (MV Buck)
- 3 linear regulators with power and hibernate management, including V_{REF} for ADC
- Power and temperature monitor, warning, and fault detection

Figure 10-1 CPM Block Diagram

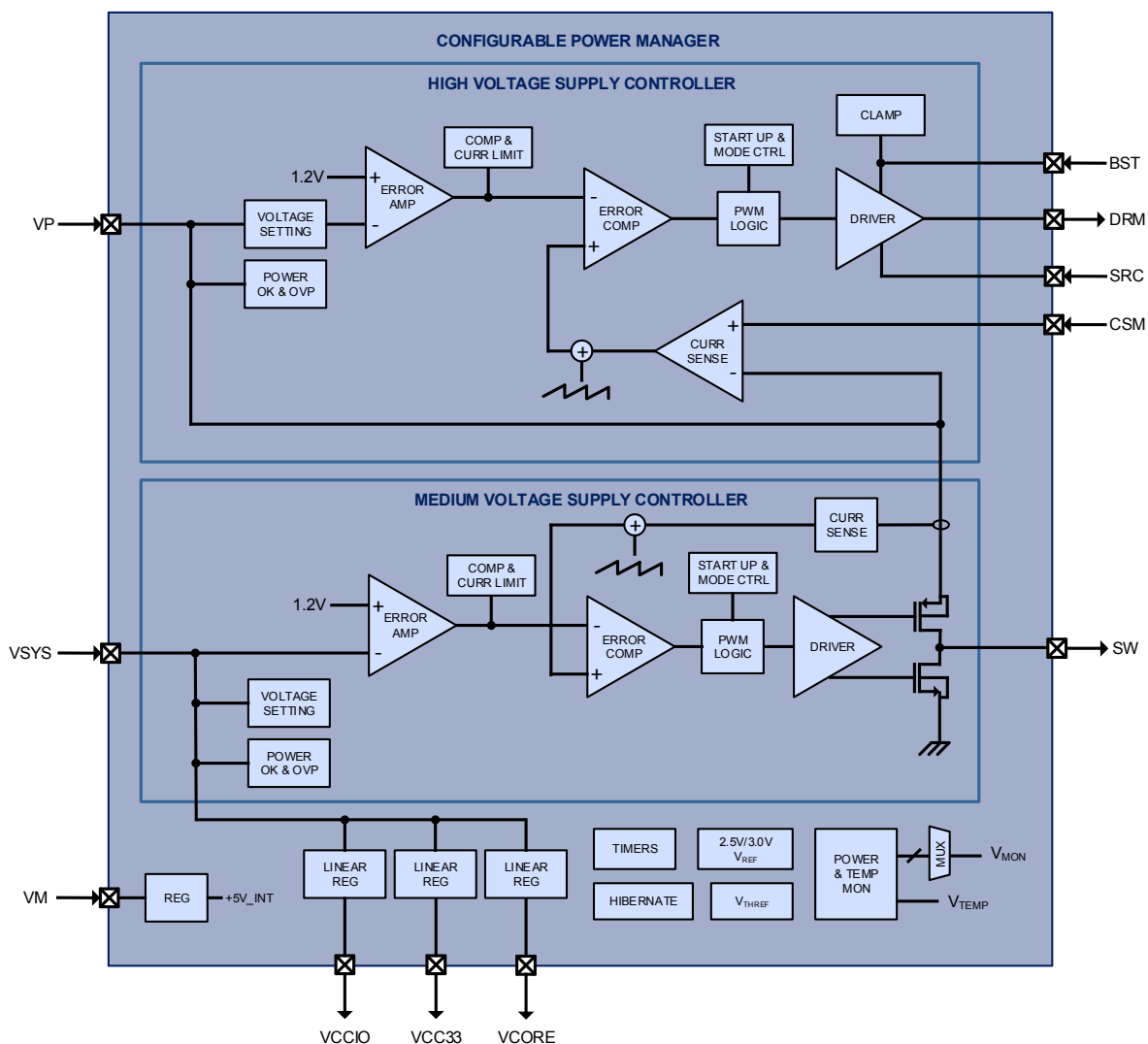

10.2 Functional Description

The Configurable Power Manager (Figure 10-1) is optimized to efficiently provide “all-in-one” power management required by the PAC® and associated application circuitry. It incorporates a high-voltage

power supply controller that is used to convert power from a DC input source to generate a main supply output V_P . There is also an integrated medium-voltage buck DC/DC regulator to generate V_{SYS} .

Three other linear regulators provide V_{CCIO} , V_{CC33} , and V_{CORE} supplies for 3.3V I/O, 3.3V mixed signal, and 1.9V microcontroller core circuitry. The power manager also handles system functions including internal reference generation, timers, hibernate mode management, and power and temperature monitoring.

10.3 High-Voltage Supply Controller (HV-BUCK)

The PAC5232 contains a High-Voltage Supply Controller for a Buck DC/DC. This power supply is used to supply the various regulators in the PAC5232, as generating the V_P gate drive voltage for the Application Specific Driver Manager (ASPD).

The HV-BUCK controller drives an external power MOSFET for pulse-width modulation switching of an inductor or transformer for power conversion. The VM is the HV-BUCK supply controller input. The DRM output drives the gate of the N-CH MOSFET between the V_M on state and V_{SS} off state at proper duty cycle and switching frequency to ensure that the main supply voltage V_P is regulated. The gate of the high-side power MOSFET is connected to the DRM pin and the source of the high-side power MOSFET is connected to SRC.

The V_P regulation voltage is initially set to 12V during start up, and can be reconfigured to be 15V by the microcontroller after initialization. When V_P is lower than the target regulation voltage, the internal feedback control circuitry causes the inductor current to increase to raise V_P . Conversely, when V_P is higher than the regulation voltage, the feedback loop control causes the inductor current to decrease to lower V_P . The feedback loop is internally stabilized. The output current capability of the switching supply is determined by the external current sense resistor. The inductor current signal is sensed differentially between the CSM pin and V_P , and has a peak current limit threshold of 0.2V.

Figure 10-2 HV-BUCK Example

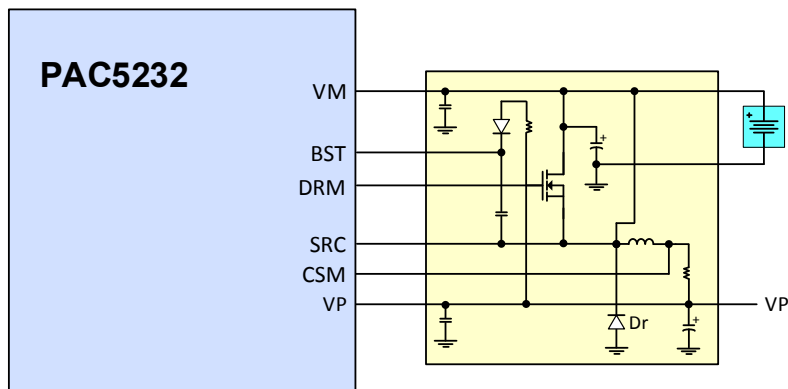

The switching frequency and output voltage of the HV-BUCK can be reconfigured by the MCU. The switching frequency can be configured to be between 50kHz and 400kHz and the gate drive output voltage can be configured to either 12V or 15V to work for a range of MOSFET or IGBT based inverters.

The Rectifier Diode (Dr) must be a low QRR diode.

10.3.1 HV-BUCK Re-start Handling

The HV-BUCK has a safety re-start mechanism that protects the device and external components in case of a DC/DC failure. This mechanism samples VM and VP when the MV-BUCK is re-started and may insert a delay before it allows the power supply to be re-started, in case of some type of short or damage with the power supply components on the PCB.

The re-start handling operates as described below.

In PAC5232, if the DC/DC has been disabled due to VM falling below $V_{UVLOF;VM}$, VM is sampled and if $VM > 10V$, then a 350ms delay is inserted, before sampling VM again and attempting a re-start of the DC/DC. Once the delay has expired and $VM > V_{UVLOR;VM}$, then the DC/DC will re-start. If VM falls below 8V, the DC/DC will re-start as an initial start-up without the 350ms delay.

In PAC5232A, if the DC/DC has been disabled due to VM falling below $V_{UVLOF;VM}$, VM is sampled and as soon as $VM > V_{UVLOR;VM}$, then the DC/DC will re-start. In this case, there is no delay before the re-start of the DC/DC.

In both PAC5232 and PAC5232A, if VM is $> VM$ UVLO falling ($V_{UVLOF;VM}$) but $VP < VP$ UVLO falling ($V_{UVLOF;VP}$) then the DC/DC is disabled and a 350ms delay is inserted. After this delay, the DC/DC is re-started.

10.4 Medium-Voltage Buck Regulator (MV-BUCK)

The PAC5232 contains a Medium-Voltage Buck Switching Regulator that generates a 5V, 200mA supply for the device, as well as PCB functions.

The SW pin is the switch node of the Buck regulator. The Power MOSFET is integrated, so connect this pin to VSYS through an external inductor. The VSYS pin is the 5V regulator output, which should be bypassed to ground.

Figure 10-3 MV-BUCK Switching Regulator Example

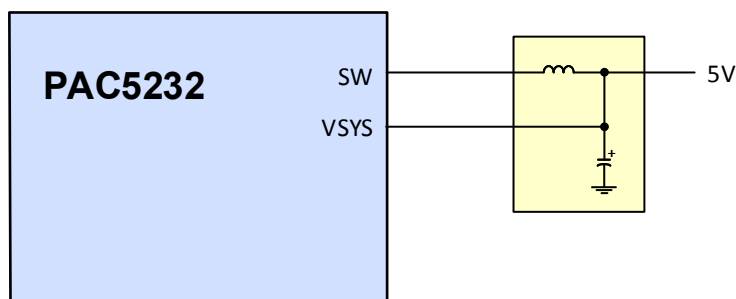

The output of VSYS is fixed at 5V and the switching frequency is 1.33MHz. This regulator supplies at least 200mA. This buck regulator offers better thermal and efficiency performance.

10.5 Linear Regulators

The CPM includes three additional linear regulators. VSYS supplies these three regulators. Once VSYS is above 4.5V, these three additional 40mA linear regulators for VCCIO, VCC33, and VCORE supplies sequentially power up.

Figure 10-4 Linear Regulators Example

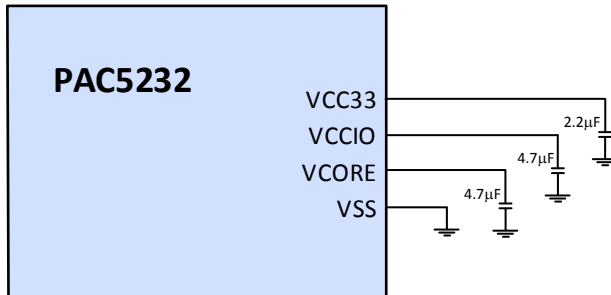

The figure above shows typical circuit connections for the linear regulators. The VCCIO regulator generates a dedicated 3.3V supply for IO. The VCC33 and VCORE regulators generate 3.3V and 1.9V, respectively. When VSYS, VCCIO, VCC33, and VCORE are all above their respective power good thresholds, and the configurable power on reset duration has expired, the microcontroller is initialized.³

10.6 Power-up Sequence

The CPM follows a typical power up sequence as in the Figure 10-5 below.

Figure 10-5 Power-Up Sequence

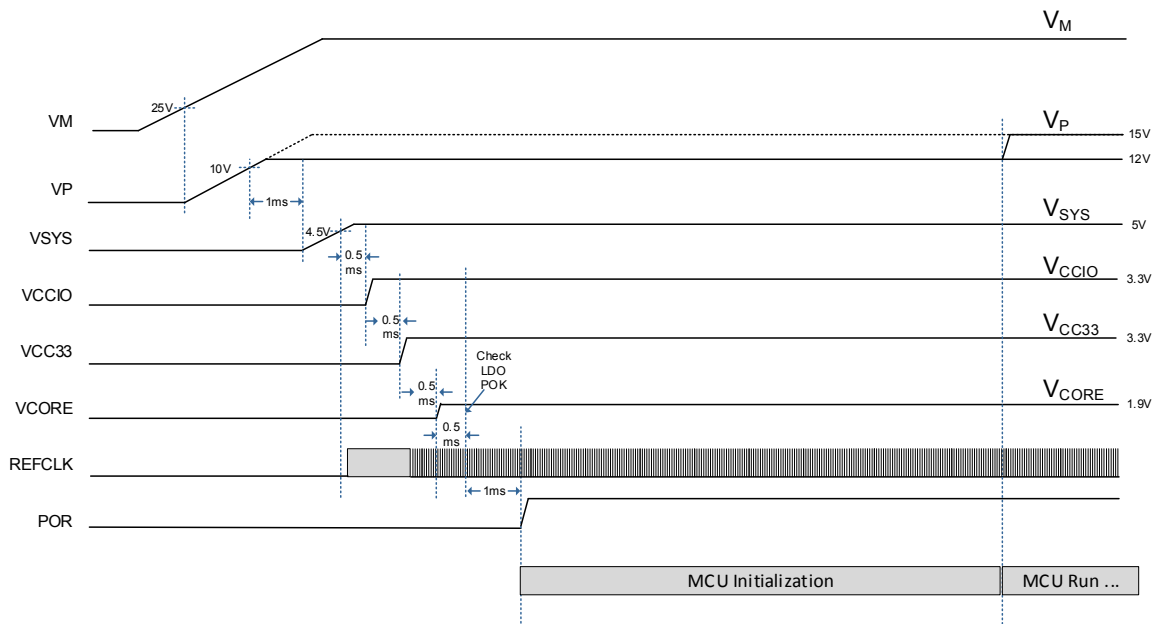

A typical sequence begins with motor power supply (VM) being applied and rising to 25V. When VM rises to 25V, the HV-BUCK controller is started and VP starts to rise. When VP rises over the UVLO rising threshold, then there is a 1ms delay and then the MV-BUCK is enabled. When VSYS rises to 4.5V, then

³ Note that the VCORE LDO may not have any addition load on it from the PCB. The only components connected to VCORE should be a bypass capacitor to ground.

there is a 0.5ms delay and the VCCIO LDO is enabled. Then there is a 0.5ms delay and the VCC33 LDO is enabled. Then there is a 0.5ms delay and the VCORE LDO is enabled.

There is then a 0.5ms delay and the power good threshold of all LDOs is checked. If all are OK, then there is an additional 1ms delay, then the POR signal is asserted to the MCU and it begins executing firmware.

During the firmware initialization process, the MCU may change the VP output voltage setting from the 12V default to 15V.

10.7 Hibernate Mode

The IC can go into an ultra-low power hibernate mode via the microcontroller firmware or via the optional push button (PBTN, see *Push Button* description in *Configurable Analog Front End*). In hibernate mode, only a minimal amount (typically 19µA at 56V) of current is used by V_M , and the CPM controller and all internal regulators are shut down to eliminate power drain from the output supplies. The system exits hibernate mode after a wake-up timer duration (configurable from 125ms to 8s or infinite) has expired or, if push button enabled, after an additional push button event has been detected. When exiting the hibernate mode, the power manager goes through the start up cycle and the microcontroller is reinitialized. Only the persistent power manager status bits (resets and faults) are retained during hibernation.

10.8 Power and Temperature Monitor

Whenever any of the V_{SYS} , V_{CCIO} , V_{CC33} , or V_{CORE} power supplies falls below their respective power good threshold voltage, a fault event is detected and the microcontroller is reset. The microcontroller stays in the reset state until V_{SYS} , V_{CCIO} , V_{CC33} , and V_{CC18} supply rails are all good again and the reset time has expired. A microcontroller reset can also be initiated by a maskable temperature fault event that occurs when the IC temperature reaches 165°C. The fault status bits are persistent during reset, and can be read by the microcontroller upon re-initialization to determine the cause of previous reset.

A power monitoring signal V_{MON} is provided onto the ADC pre-multiplexer for monitoring various internal power supplies. V_{MON} can be set to be V_{CORE} , $0.4 \cdot V_{CORE}$, $0.4 \cdot V_{CC33}$, $0.4 \cdot V_{CCIO}$, $0.4 \cdot V_{SYS}$, $0.1 \cdot V_P$, or the internal compensation voltage V_{COMP} for switching supply power monitoring.

For power and temperature warning, an IC temperature warning event at 140°C are provided as a maskable interrupt to the microcontroller. This warning allows the microcontroller to safely power down the system.

In addition to the temperature warning interrupt and fault reset, a temperature monitor signal is provided onto the ADC pre-multiplexer for IC temperature measurement.

This value has a compensation coefficient available in INFO FLASH that can be used to obtain an accurate temperature. The parameter VT300K will be stored in INFO FLASH and will indicate the compensation factor.

The temperature can then be obtained by the following formula:

$$V_{TEMP_KELVIN} = 300 * (V_M + 0.075) / (VT300K + 0.075)$$

For information on the location of this temperature coefficient, see the PAC5232 User Guide.

10.9 Voltage Reference

The reference block includes a 1.2V high-precision reference voltage used internally and for all the LDOs. There is also a high-accuracy 2.5V reference for the ADC V_{REF} on the MCU. There is also a 4-level programmable threshold voltage V_{THREF} (0.1V, 0.2V, 0.5V, and 1.25V).

10.10 Electrical Characteristics

Table 10-1 High-Voltage Buck Controller Electrical Characteristics

($V_M = 30V$, $V_P = 12V$ and $T_J = 25^\circ C$ unless otherwise specified)

SYMBOL	PARAMETER	CONDITIONS	MIN	TYP	MAX	UNIT
$I_{HIB;VM}$	V_M hibernate mode supply current	Hibernate mode, $V_M = 56V$		19	26	μA
		Hibernate mode, $V_M = 80V$		22.5		μA
$V_{UVLOR;VM}$	V_M UVLO rising		23	25	27	V
$V_{UVLOF;VM}$	V_M UVLO hysteresis			8		V
$V_{REF;VP}$	V_P output regulation voltage	Set to 12V	-5%	12	-5%	V
$k_{POKR;VP}$	V_P power OK threshold	V_P rising		91		%
$k_{POKF;VP}$		V_P falling		87		%
$k_{OVR;VP}$	V_P OV protection threshold	V_P rising, blanking = 10 μs		130		%
$t_{ONMIN;DRM}$	DRM minimum on time		90	200	300	ns
$t_{OFFMIN;DRM}$	DRM minimum off time		390	600	1150	ns
$V_{UVLOR;VP}$	V_P UVLO rising			10		V
$V_{UVLOF;VP}$	V_P UVLO falling			8		V
$V_{CSM;ILIM}$	CSM current limit threshold		-12%	0.2	12%	V
$F_{S;DRM}$	Switching frequency	Frequency setting: 50kHz, 100kHz (default), 200kHz, 400kHz	-5		5	%
$I_{SOURCE;DRM}$	DRM output high source current			100		mA
$I_{SINK;DRM}$	DRM output low sink current			200		mA
	HV-BUCK inductor value			100		μH
I_{DSG}	Discharge current			10		mA
V_M	Motor voltage range		0		160	V
$V_{SRC;VSS}$	SRC to ground range		-10		$V_M + 10$	V
$V_{SRC;VM}$	SRC to VM range				10	V
$V_{BST;VSS}$	BST to ground range				175	V

Table 10-2 Medium-Voltage Buck Controller Electrical Characteristics

($V_M = 30V$, $V_P = 12V$ and $T_J = 25^\circ C$ unless otherwise specified)

SYMBOL	PARAMETER	CONDITIONS	MIN	TYP	MAX	UNIT
V_{SYS}	V_{SYS} output voltage accuracy		-3%	5	3%	V
F_{SW}	Switching frequency		-5%	1.33	5%	MHz
$I_{V_{SYS,LIM}}$	V_{SYS} current limit		420		550	mA
$I_{V_{SYS}}$	V_{SYS} output current	$V_{SYS} > 3V$	200			mA
		$V_{SYS} < 2.5V$	100			mA
$V_{POK:V_{SYS}}$	V_{SYS} power OK threshold	Rising	4.25	4.5	4.75	V
		Falling		4.2		V
	V_{SYS} power OK blanking delay			10		μs
	MV-BUCK inductor value	Current rating of at least 750mA	6.8 – 20%		10 + 20%	μH
$V_{UVLO:V_{SYS}}$	V_{SYS} UVLO	Rising		4.5		V
		Falling		4.2		V
$V_{OVP:V_{SYS}}$	V_{SYS} OVP	Rising		5.5		V
		Falling		5.2		V

Table 10-3 Linear Regulators Electrical Characteristics

($V_P = 12V$ and $T_A = -40^\circ C$ to $105^\circ C$ unless otherwise specified)

SYMBOL	PARAMETER	CONDITIONS	MIN	TYP	MAX	UNIT
V_{CCIO}	V_{CCIO} output voltage	Load = 1mA	-3%	3.3	3%	V
V_{CCIO}	V_{CCIO} output voltage	Load = 1mA	-3%	3.3	3%	V
V_{CORE}^4	V_{CORE} output voltage	Load = 1mA	-3%	1.9	3%	V
$I_{LIM,VCCIO}$	V_{CCIO} current limit		40	65		mA
$I_{LIM,VCC33}$	V_{CC33} current limit		40	65		mA
$I_{LIM,VCORE}$	V_{CORE} current limit		40	65		mA
	LDO current fold back			50		%
$t_{POK,BLANK}$	Power OK blanking delay	$V_{CCIO}, V_{CC33}, V_{CORE}$		10		μs
R_{DISCH}	Output discharge resistance	LDO off		300		Ohm
C_{VCCIO}	V_{CCIO} stable output capacitance		1		4.7	μF
C_{VCC33}	V_{CC33} stable output capacitance		1		4.7	μF
C_{VCORE}	V_{CORE} stable output capacitance		1		4.7	μF
$V_{LDO,POK}$	LDO power OK rising threshold	Hysteresis = 10%	85	90	95	%

⁴ Note that the V_{CORE} LDO may not have any other loads. The only connection to the V_{CORE} pin should be a bypass capacitor to ground.

10.11 Typical Performance Characteristics

(T_A = 25°C unless otherwise specified)

Figure 10-6 VDDIO LDO Voltage vs. Current

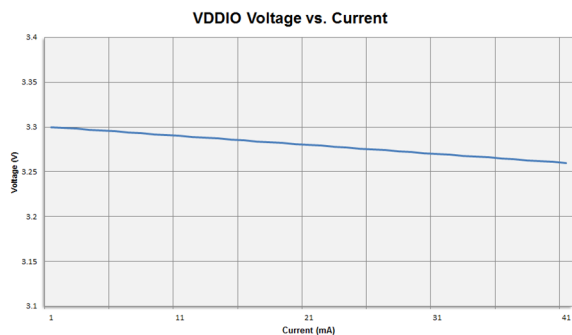

Figure 10-8 VCORE LDO Voltage vs. Current

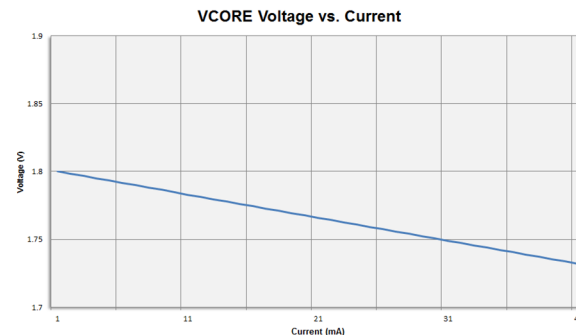
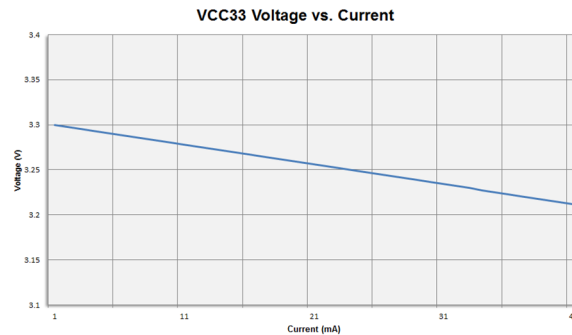

Figure 10-7 VCC33 LDO Voltage vs. Current



11 CONFIGURABLE ANALOG FRONT END (CAFE)

11.1 Features

- 10 Configurable Analog I/O signals
 - Gain mode, comparator mode, I/O mode, special mode
- 3 High-Performance, Configurable Differential Amplifiers
- 4 High-Performance, Configurable Single-Ended Amplifiers
- Two high-speed comparators with protection functions
- Phase to phase, phase to center-tap modes
- Bi-directional, asymmetric configurable comparator hysteresis
- Push-button input for entering/exiting hibernate mode
- Low-frequency Clock Output for safety applications

11.2 Block Diagram

Figure 11-1 Configurable Analog Front End

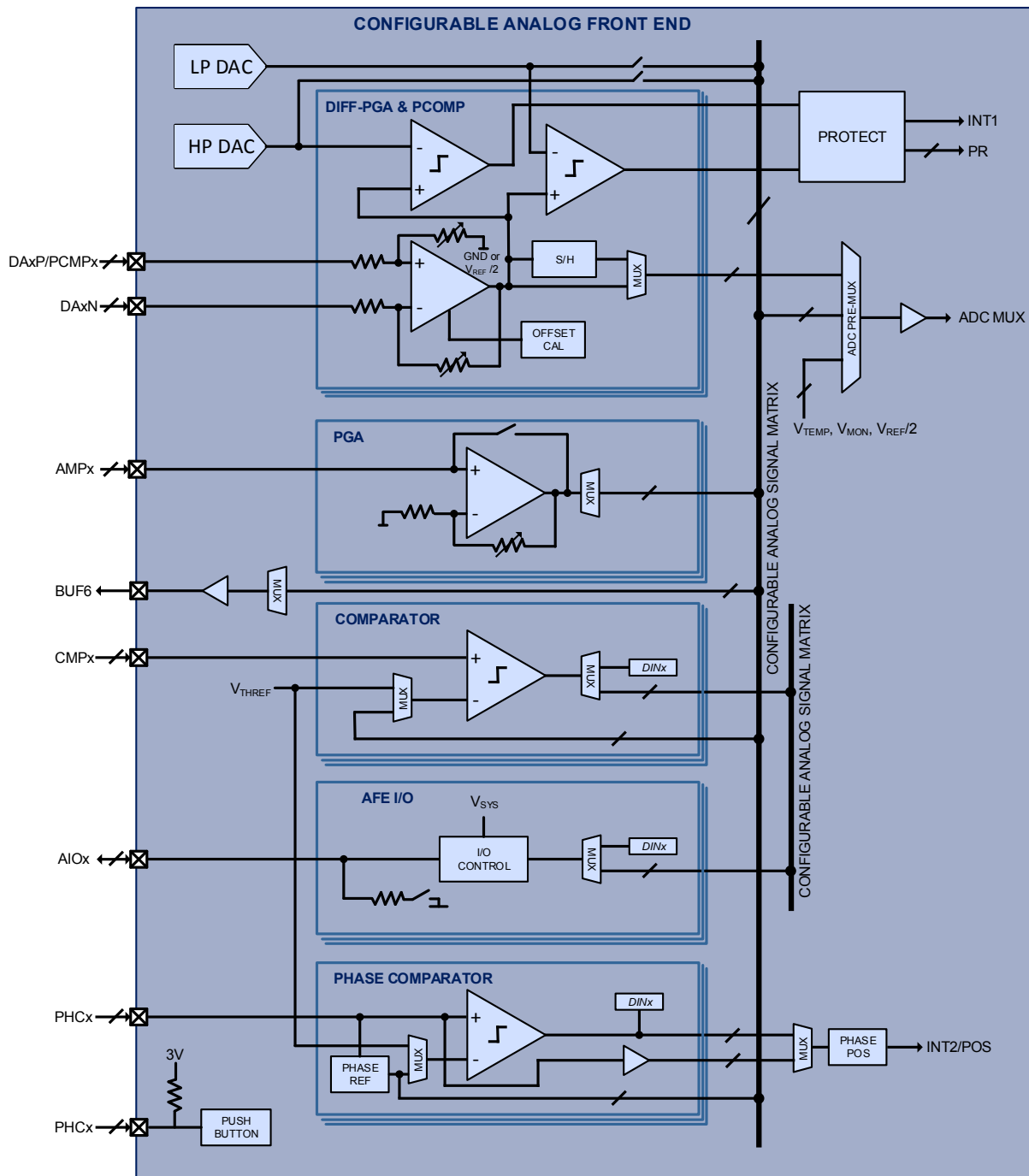

11.3 Functional Description

The device includes a Configurable Analog Front End (CAFE, Figure 11-1) accessible through 8 analog and I/O pins. These pins can be configured to form flexible interconnected circuitry made up of 3 differential programmable gain amplifiers, 4 single-ended programmable gain amplifiers, 4 general purpose comparators, 3 phase comparators, 10 protection comparators, and one buffer output. These pins can also be programmed as analog feed-through pins, or as analog front end I/O pins that can function as digital inputs or digital open-drain outputs. The PAC® proprietary configurable analog signal matrix (CASM) and configurable digital signal matrix (CDSM) allow real time asynchronous analog and digital signals to be routed in flexible circuit connections for different applications. A push button function is provided for optional push button on, hibernate, and off power management function.

11.4 Differential Programmable Gain Amplifier (DA)

The DAXP and DAXN pin pair are positive and negative inputs, respectively, to a differential programmable gain amplifier. The differential gain can be programmable to be 1x, 2x, 4x, 8x, 16x, 32x, and 48x for zero ohm signal source impedance. The differential programmable gain amplifier has -0.3V to 2.5V input common mode range, and its output can be configured for routing directly to the ADC pre-multiplexer, or through a sample-and-hold circuit synchronized with the ADC auto-sampling mechanism. Each differential amplifier is accompanied by offset calibration circuitry, and two protection comparators for protection event monitoring. The programmable gain differential amplifier is optimized for use with signal source impedance lower than 500Ω and with matched source impedance on both positive and negative inputs for minimal offset. The effective gain is scaled by $13.5k / (13.5k + R_{SOURCE})$, where R_{SOURCE} is the matched source impedance of each input.

11.5 Single-Ended Programmable Gain Amplifier (AMP)

Each AMPx input goes to a single-ended programmable gain amplifier with signal relative to V_{SS} . The amplifier gain can be programmed to be 1x, 2x, 4x, 8x, 16x, 32x, and 48x, or as analog feed-through. The programmable gain amplifier output is routed via a multiplexer to the configurable analog signal matrix CASM.

11.6 General Purpose Comparator (CMP)

The general purpose comparator takes the CMPx input and compares it to either the programmable threshold voltage (V_{THREF}) or a signal from the configurable analog signal matrix CASM. The comparator has 0V to V_{SYS} input common mode range, and its polarity-selectable output is routed via a multiplexer to either a data input bit or the configurable digital signal matrix CDSM. Each general purpose comparator has two mask bits to prevent or allow rising or falling edge of its output to trigger second microcontroller interrupt INT2, where INT2 can be configured to active protection event PR.

11.7 Phase Comparator (PHC)

The phase comparator takes the PHCx input and compares it to either the programmable threshold voltage (V_{THREF}) or a signal from the configurable analog signal matrix CASM. The comparison signal can be set to a phase reference signal generated by averaging the PHCx input voltages. In a three-phase motor control application, the phase reference signal acts as a virtual center tap for BEMF detection. The PHCx inputs are optionally fed through to the CASM. The PHC inputs can be compared to the virtual center-tap, or phase to phase for the most efficient BEMF zero-cross detection.

The phase comparator signals can also be configured to the other two phase comparators (between AIO7, AIO8 and AIO9), to perform phase to phase comparisons.

The comparator blanking time is configurable. The blanking time configuration supports bi-directional and asymmetric configurations, which enables hysteresis for rising and falling signals.

The phase comparator has 0V to V_{SYS} input common mode range, and its polarity-selectable output is routed to a data input bit and to the phase/position multiplexer synchronized with the auto-sampling sequencers.

11.8 Protection Comparator (PCMP)

Two protection comparators are provided in association with each differential programmable gain amplifier, with outputs available to trigger protection events and accessible as read-back output bits. The HP comparator compares the amplifier output to the 10-bit HP DAC output voltage, with full scale voltage of 2.5V. The limit protection (LP) comparator compares the differential programmable gain amplifier output to the 10-bit LP DAC output voltage, with full scale voltage of 2.5V.

Each protection comparator has a mask bit to prevent or allow it to trigger the main microcontroller interrupt INT1. Each protection comparator also has one mask bit to prevent or allow it to activate protection event PR. These two protection events can be used directly by protection circuitry in the Application Specific Power Drivers (ASPD) to protect devices being driven.

11.9 Analog Output Buffer (BUF)

A subset of the signals from the configurable analog signal matrix CASM can be multiplexed to the BUF6 pin for external use. The buffer offset voltage can be minimized with the built-in swap function.

11.10 Analog Front End I/O (AIO)

The PAC5232 has 10 AIOx pins that are available. In the analog front end I/O mode, the pin can be configured to be a digital input or digital open-drain output. The AIOx input or output signal can be set to a data input or output register bit, or multiplexed to one of the signals in the configurable digital signal matrix CDSM. The signal can be set to active high (default) or active low, with V_{SYS} supply rail. Where AIO_{6,7,8,9} supports microcontroller interrupt for external signals. Each has two mask bits to prevent or allow rising or falling edge of its corresponding digital input to trigger second microcontroller interrupt INT2.

11.11 Push Button (PBTN)

The push button PBTN, when enabled, can be used by the MCU to detect a user active-low push button event and to put the system into an ultra-low-power hibernate mode. Once the system is in hibernate mode, PBTN can be used to wake up the system.

In addition, PBTN can also be used as a hardware reset for the microcontroller when it is held low for longer than 8s during normal operation. The PBTN input is active low and has a 55kΩ pull-up resistor to 3V.

11.12 HP DAC and LP DAC

The 10-bit HP DAC can be used as the comparison voltage for the high-speed protection (HP) comparators, or routed for general purpose use via the AB2 signal in the CASM. The HP DAC output full scale voltage is 2.5V.

The 10-bit LP DAC can be used as the comparison voltage for the limit protection (LP) comparators, or routed for general purpose use via the AB3 signal in the CASM. The LP DAC output full scale voltage is 2.5V.

11.13 ADC Pre-Multiplexer

The ADC pre-multiplexer is a 16-to-1 multiplexer that selects between the 3 differential programmable gain amplifier outputs, AB1 through AB9, temperature monitor signal (V_{TEMP}), power monitor signal (V_{MON}), and offset calibration reference ($V_{REF} / 2$). The ADC pre-multiplexer can be directly controlled or automatically scanned by the auto-sampling sequencer.

When the ADC pre-multiplexer is automatically scanned, the unbuffered or sensitive signals should be masked by setting appropriate register bits.

11.14 Configurable Analog Signal Matrix (CASM)

The CASM has 9 general purpose analog signals labeled AB1 through AB9 that can be used for:

- Routing the single-ended programmable gain amplifier or analog feed-through output to AB1 through AB9
- Routing an analog signal via AB1, AB2, or AB3 to the negative input of a general purpose comparator or phase comparator
- Routing the 10-bit HP DAC output to AB2
- Routing the 10-bit LP DAC output to AB3
- Routing analog signals via AB1 through AB12 to the ADC pre-multiplexer
- Routing phase comparator feed-through signals to AB7, AB8, and AB9, and averaged voltage to AB1

11.15 Configurable Digital Signal Matrix (CDSM)

The CDSM has 7 general purpose bi-directional digital signals labeled DB1 through DB7 that can be used for:

- Routing the AIOx input to or output signals from DB1 through DB7
- Routing the general purpose comparator output signals to DB1 through DB7

11.16 Low-Frequency Clock Output

The PAC5232 has a configurable low-frequency clock output. When enabled, the device will output a 250Hz, 50% duty cycle clock to the CLKOUT pin.

The supported clock frequencies are 250Hz, 500Hz, 1kHz or 2kHz.

11.17 Cycle-by-cycle Current Limit

The PAC5232 contains hardware support for cycle by cycle current limit. The user may configure this feature to use the LPCOMP DAC as the current threshold. The CAFE will automatically perform duty cycle truncation to lower current at any time the associated phase current is greater than the setting of the LPCOMP DAC.

11.18 Temperature Protection

The PAC5232 contains an internal temperature sensor that detects temperature warnings and faults.

When the device temperature reaches the temperature warning threshold (140°C), the device sets an over-temperature warning condition. The user may configure a mask-able interrupt the MCU for this condition.

When the device temperature reaches the temperature fault threshold (165 °C), the device is shut down. There is no interrupt for this condition.

For more details on the register settings for over-temperature protection see the PAC5232 User Guide and related application notes.

11.19 Electrical Characteristics

Table 11-1 Differential Programmable Gain Amplifier (DA) Electrical Characteristics (AIO<5:0>)

(T_A = -40°C to 105°C unless otherwise specified.)

SYMBOL	PARAMETER	CONDITIONS	MIN	TYP	MAX	UNIT
V _{ICMR,DA}	Input common mode range		-0.3		2.5	V
V _{OLR,DA}	Output linear range		0.1		V _{sys} - 0.1	V
V _{SHR,DA}	Sample and hold range		0.1		3.5	
I _{CC,DA}	Operating supply current	Each enabled amplifier		150		μA
V _{OS,DA}	Input offset voltage	Gain = 8x	-8		8	mV
K _{CMRR,DA}	Common mode rejection ratio		50	80		dB
	Slew rate	Gain = 8x	10			V/μs
R _{INDIF,DA}	Differential input impedance			27		kΩ
t _{ST,DA}	Settling time	To 1% of final value			360	ns
A _{VZI,DA}	Differential amplifier gain (zero ohm source impedance)	Gain = 1x		1		%
		Gain = 2x		2		
		Gain = 4x		4		
		Gain = 8x, V _{DAXP} =V _{DAXN} =0V, T _A = 25°C	-2		2	
		Gain = 16x		16		
		Gain = 32x		32		
		Gain = 48x		48		

Table 11-2 Single-Ended Programmable Gain Amplifier (AMP) Electrical Characteristics (AIO<9:6>)

(V_{SYS} = 5V, V_{CCIO} = 3.3V and T_A = -40°C to 105°C unless otherwise specified.)

SYMBOL	PARAMETER	CONDITIONS	MIN	TYP	MAX	UNIT
V _{ICMR,AMP}	Input common mode range		0		V _{SYS}	V
V _{OLR,AMP}	Output linear range		0.1		V _{SYS} - 0.1	V
I _{CC,AMP}	Operating supply current	Each enabled amplifier		80	120	μA
V _{OS,AMP}	Input offset voltage	Gain = 8x	-10		10	mV
	Slew rate	Gain = 1x	10			V/μs
t _{ST,AMP}	Settling time	To 1% of final value			360	ns
A _{V,AMP}	Amplifier gain	Gain = 1x		1		%
		Gain = 2x		2		
		Gain = 4x		4		
		Gain = 8x, V _{AMPX} =125mV, T _A = 25°C	-2		2	
		Gain = 16x		16		
		Gain = 32x		32		
		Gain = 48x		48		
t _{ST,AMP}	Settling time	To 1% of final value			350	ns

Table 11-3 General Purpose Comparator (CMP) Electrical Characteristics (AIO<9:6>)

(T_A = -40°C to 105°C unless otherwise specified.)

SYMBOL	PARAMETER	CONDITIONS	MIN	TYP	MAX	UNIT
V _{ICMR,CMP}	Input common mode range		0		V _{SYS}	V
I _{CC,CMP}	Operating supply current	Each enabled comparator		35		μA
V _{OS,CMP}	Input offset voltage		-10		10	mV
V _{HYS,CMP}	Hysteresis			22		mV
t _{DEL,CMP}	Comparator delay				1	μs
t _{DELMODE,CMP}	Mode change blanking delay			10		μs

Table 11-4 Phase Comparator (PHC) Electrical Characteristics (AIO<9:6>)

(V_{SYS} = 5V, V_{CC33} = 3.3V and T_A = -40°C to 105°C unless otherwise specified.)

SYMBOL	PARAMETER	CONDITIONS	MIN	TYP	MAX	UNIT
V _{ICMR,PHC}	Input common mode range					V
I _{CC,PHC}	Operating supply current	Each enabled comparator		35		μA
V _{OS,PHC}	Input offset voltage		-10		10	mV
V _{HYS,PHC}	Hysteresis			23		mV
t _{DEL,PHC}	Comparator delay	10mV difference input			1	μs

Table 11-5 Special Mode Electrical Characteristics (AIO<9:7>)

(T_A = -40°C to 105°C unless otherwise specified.)

SYMBOL	PARAMETER	CONDITIONS	MIN	TYP	MAX	UNIT	
V _{ICMR:SPEC}	Input common mode range		0		V _{sys}	V	
I _{CC:SPEC}	Operating supply current	Each enabled comparator		80	120	μA	
V _{HYSYS:SPEC}	Comparator Hysteresis, HYSMODE = 0	AIO<9:7>HYS = 00b (0mV)		0		mV	
		AIO<9:7>HYS = 01b (6mV)	4	6	8	mV	
		AIO<9:7>HYS = 10b (12mV)	9	12	15	mV	
		AIO<9:7>HYS = 11b (24mV)	18	24	30	mV	
	Comparator Hysteresis, HYSMODE = 1	AIO<9:7>HYS = 00b (0mV)			0		mV
		AIO<9:7>HYS = 01b (24mV)	18	24	30	mV	
		AIO<9:7>HYS = 10b (48mV)	36	48	60	mV	
		AIO<9:7>HYS = 11b (96mV)	72	96	120	mV	

Table 11-6 Special Mode Electrical Characteristics (AIO6)

(T_A = -40°C to 105°C unless otherwise specified.)

SYMBOL	PARAMETER	CONDITIONS	MIN	TYP	MAX	UNIT
V _{ICMR:SPEC}	Input common mode range		0		V _{sys}	V
I _{CC:SPEC6}	Operating supply current			60		μA
V _{INOFF:SPEC6}	Input offset voltage		-20		20	mV
I _{OUT:SPEC6}	Output current			2		mA

Table 11-7 Analog Front End (AIO) Electrical Characteristics (AIO<9:0>)

(T_A = -40°C to 105°C unless otherwise specified.)

SYMBOL	PARAMETER	CONDITIONS	MIN	TYP	MAX	UNIT
V _{AIO}	Pin voltage range		0		5	V
V _{IH:AIO}	High-level input voltage		2.2			V
V _{IL:AIO}	Low-level input voltage				0.8	V
R _{PD:AIO}	Pull-down resistance	Input mode		1		MΩ
V _{OL:AIO}	Low-level output voltage	I _{AIOx} = 7mA, open-drain output mode			0.3	V
I _{OL:AIO}	Low-level output sink current	V _{AIOx} = 0.4V, open-drain output mode	6	14		mA
I _{LK:AIO}	High-level output leakage current	V _{AIOx} = 5V, open-drain output mode		0	10	μA

Table 11-8 Push Button (PBTN) Electrical Characteristics (AIO6)

(T_A = -40°C to 105°C unless otherwise specified.)

SYMBOL	PARAMETER	CONDITIONS	MIN	TYP	MAX	UNIT
V _{I,PBTN}	Input voltage range		0		5	V
V _{IH,PBTN}	High-level input voltage		2.2			V
V _{IL,PBTN}	Low-level input voltage				0.8	V
R _{PU,PBTN}	Pull-up resistance	To 3V, push-button input mode		50		kΩ

Table 11-9 HP DAC and LP DAC Electrical Characteristics

(T_A = -40°C to 105°C unless otherwise specified.)

SYMBOL	PARAMETER	CONDITIONS	MIN	TYP	MAX	UNIT
V _{DACREF}	DAC reference voltage	T _A = 25°C	-0.5%	2.5	0.5%	V
		T _A = -40°C to 105°C	-0.9%	2.5	0.9%	
	HP 10-bit DAN INL		-2		2	LSB
	HP 10-bit DAC DNL		-1		1	LSB
	LP 10-bit DAC INL		-2		2	LSB
	LP 10-bit DAC DNL		-1		1	LSB

Table 11-10 Low-Frequency Clock Output (CLKOUT)

(T_A = -40°C to 105°C unless otherwise specified.)

SYMBOL	PARAMETER	CONDITIONS	MIN	TYP	MAX	UNIT
F _{CLKOUT}	Low-speed clock output frequency	CLKOUT 250Hz		250		Hz
F _{CLKOUT,ERR}	Low-speed clock output frequency error	T _A = 25°C	-10		10	%
		T _A = -40°C - 105°C	-15		15	%

Table 11-11 Temperature Protection

SYMBOL	PARAMETER	CONDITIONS	MIN	TYP	MAX	UNIT
T _{WARN}	Temperature warning threshold			140		°C
T _{WARN,HYS}	Temperature warning hysteresis			10		°C
T _{WARN,BLANK}	Temperature warning blanking			10		μs
T _{FAULT}	Temperature fault threshold			165		°C
T _{FAULT,HYS}	Temperature fault hysteresis			10		°C
T _{FAULT,BLANK}	Temperature fault blanking			10		μs

12 APPLICATION SPECIFIC POWER DRIVERS (ASPD)

12.1 Features

- 3 low-side and 3 high-side gate drivers
- 2A sink/source gate driving capability
- Configurable propagation delays
- Fast fault protection
- Cycle-by-cycle current limit function
- Configurable driver break-before-make (BBM) safety function

12.2 Block Diagram

Figure 12-1 Application Specific Power Drivers

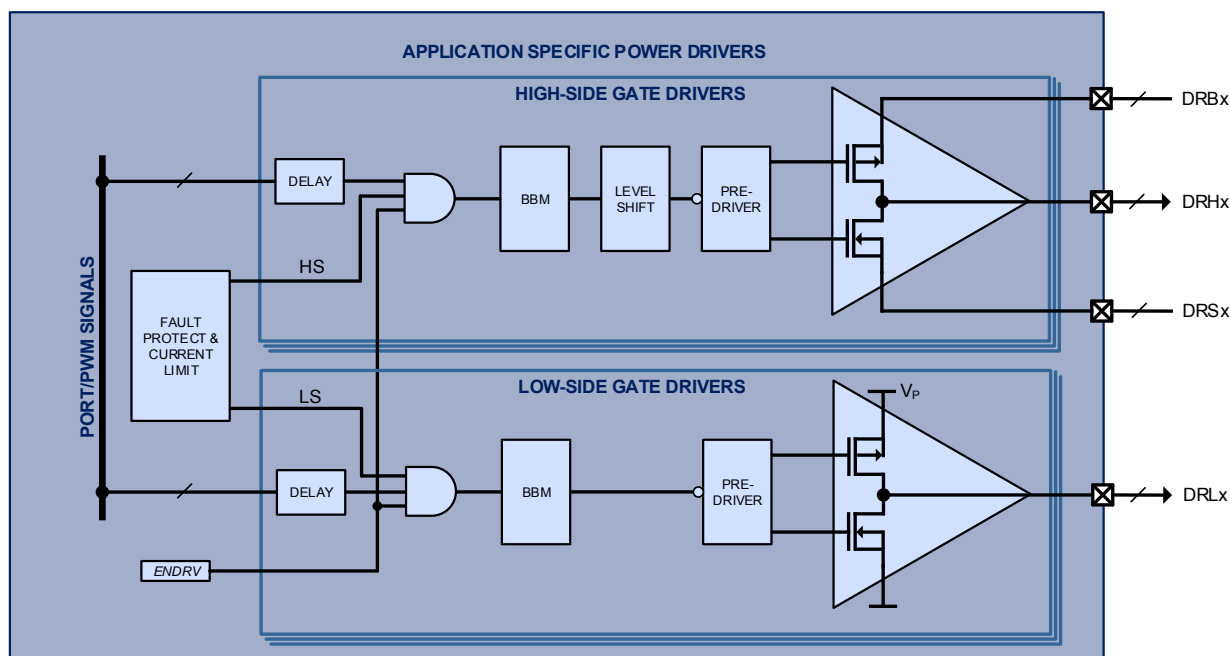

12.3 Functional Description

The Application Specific Power Drivers (ASPD, Figure 12-1) module handles power driving for power and motor control applications. The ASPD contains three low-side gate drivers (DRLx), three high-side gate drivers (DRHx). Each gate driver can drive an external MOSFET or IGBT switch in response to high-speed control signals from the microcontroller ports, and a pair of high-side and low-side gate drivers can form a half-bridge driver.

Figure 12-2 below shows typical gate driver connections and Table 12-1 shows the ASPD available resources. The ASPD gate drivers support up to a 180V source supply.

Figure 12-2 Typical Gate Driver Connections

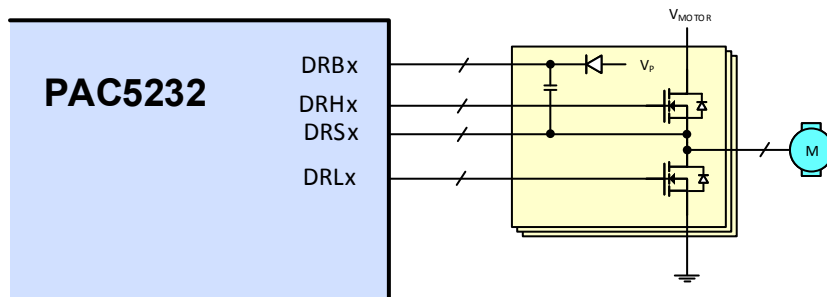

Table 12-1 Power Driver Resources by Part Numbers

PART NUMBER	LOW-SIDE GATE DRIVER		HIGH-SIDE GATE DRIVER		
	DRLx	SOURCE/SINK CURRENT	DRHx	SOURCE/BOOTSTRAP SUPPLY	SOURCE/SINK CURRENT
PAC5232	3	2A/2A	3	165V/180V	2A/2A

The ASPD includes built-in configurable fault protection for the internal gate drivers.

12.4 Low-Side Gate Driver

The DRLx low-side gate driver drives the gate of an external MOSFET or IGBT switch between the low-level power ground rail and high-level V_P supply rail. The DRLx output pin has sink and source output current capability of 2A. Each low-side gate driver is controlled by a microcontroller port signal with 4 configurable levels of propagation delay.

12.5 High-Side Gate Driver

The DRHx high-side gate driver drives the gate of an external MOSFET or IGBT switch between its low-level DRSx driver source rail and its high-level DRBx bootstrap rail. The DRSx pin can go up to 160V steady state ($V_M + 15V$ maximum). The DRHx output pin has sink and source output current capability of 2A.

The DRBx bootstrap pin can have a maximum operating voltage of 15V relative to the DRSx pin, and up to 175V steady state. The DRSx pin can have a maximum operating voltage of 10V relative to the VM pin. The DRSx pin is designed to tolerate momentary switching negative spikes down to -10V without affecting the DRHx output state. Each high-side gate driver is controlled by a microcontroller port signal with 4 configurable levels of propagation delay.

For bootstrapped high-side operation, connect an appropriate capacitor between DRBx and DRSx and a properly rated bootstrap diode from V_P to DRBx. To operate the DRHx output as a low-side gate driver, connect its DRBx pin to V_P and its DRSx pin to V_{SS} .

12.6 Power Drivers Control

All power drivers are initially disabled from power-on-reset. To enable the power drivers, the MCU must first enable the ASPD block. The gate drivers are controlled by the microcontroller ports and/or PWM signals according to Table 12-2, with configurable delays as shown in Table 12-3 Power Driver Propagation Delay.

Refer to the PAC5232 User Guide and PAC® application notes and user guide for additional information on power drivers control programming.

Table 12-2 Microcontroller Port and PWM to Power Driver Mapping

PART NUMBER	DRL0	DRL1	DRL2	DRH3	DRH4	DRH5
PAC5232	PWMA0	PWMA1	PWMA2	PWMA3/ PWMA4/ PWMB0	PWMA5/ PWMC0	PWMA6/ PWMD0

Table 12-3 Power Driver Propagation Delay

DRLx	DRHx
135ns	155ns

12.7 Gate Driver Fault Protection

The ASPD incorporates a configurable fault protection mechanism using protection signal from the Configurable Analog Front End (CAFE), designated as protection event 1 (PR) signal. The DRL0/DRL1/DRL2 drivers are designated as low-side group 1. The DRH3/DRH4/DRH5 gate drivers are designated as high-side group 1. The PR signal from the CAFE can be used to disable low-side group 1, high-side group 1, or both depending on the PR mask bit settings.

12.8 Electrical Characteristics

Table 12-4 Gate Driver Electrical Characteristics

($V_P = 12V$, and $T_A = -40^\circ C$ to $105^\circ C$ unless otherwise specified.)

SYMBOL	PARAMETER	CONDITIONS	MIN	TYP	MAX	UNIT
Low-Side Gate Drivers (DRLx pins)						
$V_{OH;DRL}$	High-level output voltage	$I_{DRLx} = -50mA$	$V_P - 0.3$			V
$V_{OL;DRL}$	Low-level output voltage	$I_{DRLx} = 50mA$			0.3	V
$I_{OHPK;DRL}$	Output high source current	10 μs pulse		2		A
$I_{OLPK;DRL}$	Output low sink current	10 μs pulse		2		A
High-Side Gate Drivers (DRHx, DRBx and DRSx pins)						
V_{DRS}	Level-shift driver source voltage range		-10		$V_M + 10$	V
V_{DRB}	Bootstrap pin voltage range	Relative to V_{DRS}	10		20	V
		Relative to VSS			175	V
$V_{UVLO;DRB}$	Bootstrap UVLO threshold	V_{DRBx} rising	8.5			V
		Hysteresis		1		V
$I_{BS;DRB}$	Bootstrap supply current	Current from DRBx to DRSx		28		μA
$I_{OS;DRB}$	Offset supply current	Current from DRBx to ground		10		μA
$V_{OH;DRH}$	High-Level output voltage	$I_{DRHx} = -50mA$	$V_{DRBx} - 0.3$			V
$V_{OL;DRH}$	Low-level output voltage	$I_{DRHx} = 50mA$			$V_{DRSx} + 0.3$	V
$I_{OHPK;DRH}$	Output high source current	10 μs pulse		2		A
$I_{OLPK;DRL}$	Output low sink current	10 μs pulse		2		A
High-Side and Low-Side Gate Driver Propagation Delay						
t_{PD}	Propagation Delay ⁵	Delay setting 00b	-50%	Delay + 0	50%	ns
		Delay setting 01b	-50%	Delay + 50	50%	ns
		Delay setting 10b	-50%	Delay + 100	50%	ns
		Delay setting 11b	-50%	Delay + 200	50%	ns

⁵ Delay from Table 12-3 Power Driver Propagation Delay

13 ADC WITH AUTO-SAMPLING SEQUENCER

13.1 ADC Block Diagram

Figure 13-1 ADC with Auto-Sampling Sequencer

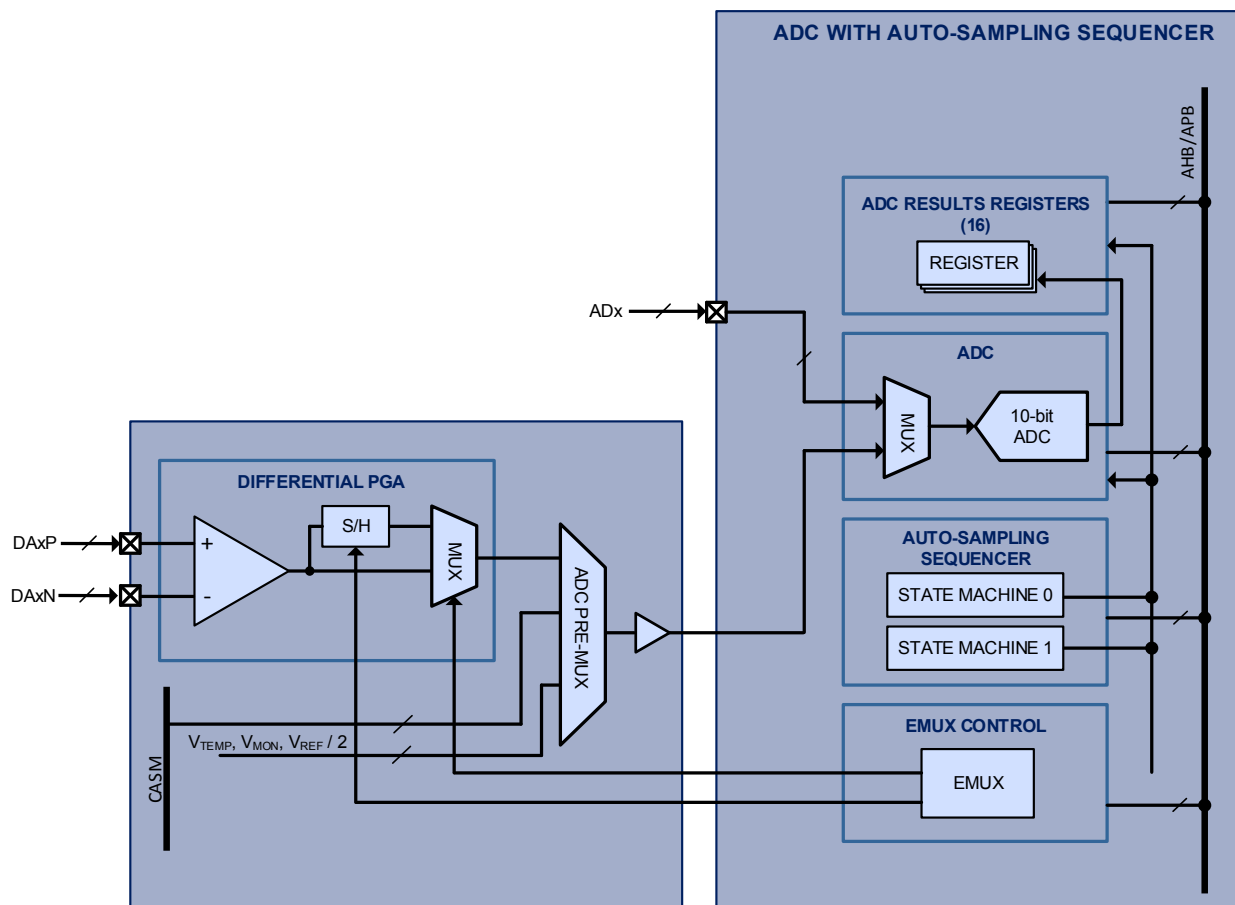

13.2 Functional Description

13.2.1 ADC

The analog-to-digital converter (ADC) is a 10-bit successive approximation register (SAR) ADC with 1 μ s conversion time and up to 1MSPS capability. The ADC input clock has a user-configurable divider from /1 to /8 of the system clock. The integrated analog multiplexer allows selection from up to 6 direct ADx inputs, and from up to 10 analog inputs signals in the Configurable Analog Front End (CAFE), including up to 3 differential input pairs. The ADC can be configured for repeating or non-repeating conversions and can interrupt the microcontroller when a conversion is finished.

13.2.2 Auto-Sampling Sequencer

Two independent and flexible auto-sampling sequencer state machines allow signal sampling using the ADC without interaction from MCU. Each auto-sampling sequencer state machine can be programmed to take and store up to 8 samples each in the ADC result registers from different analog inputs, is able to control the ADC MUX and ADC Pre-mux as well as the precise timing of the S/H in the Configurable Analog Front-End (CAFE). The sampling start of the auto-sampling sequencer can be precisely triggered using timers A, B, C, or D or any of their associated PWM edges (high-to-low or low-to-high). It also supports manual start or a ping-pong-scheme, where one auto-sampling sequencer state machine triggers the other when it finishes sampling.

The auto-sampling sequencer can interrupt the microcontroller when either conversion sequence is finished.

13.2.3 EMUX Control

A dedicated low latency interface controllable by the auto-sampling sequencer or register control allows changing the ADC pre-multiplexer and asserting/de-asserting the S/H circuit in the Configurable Analog Front-End (CAFE), allowing back to back conversions of multiple analog inputs without MCU interaction.

For more information on the ADC and Auto-Sequencer, see the PAC5232 User Guide.

13.3 Electrical Characteristics

Table 13-1 ADC and Sequencer Electrical Characteristics

(V_{CCIO} = 5V and T_A = -40°C to 105°C unless otherwise specified.)

SYMBOL	PARAMETER	CONDITIONS	MIN	TYP	MAX	UNIT
ADC						
f _{ADCCLK}	ADC conversion clock input				16	MHz
f _{ADCCONV}	ADC conversion time	f _{ADCCLK} = 16MHz			1	μs
	ADC resolution			10		bits
	ADC effective resolution		9.2			bits
	ADC differential non-linearity (DNL)			±0.5		LSB
	ADC integral non-linearity (INL)			±1		LSB
	ADC offset error			0.6		%FS
	ADC gain error			0.12		%FS
REFERENCE VOLTAGE						
V _{REFADC}	ADC reference voltage input	V _{REF} = 2.5V		2.5		V
	ADC reference voltage input error	T _A = 25°C	-0.5		0.5	%
SAMPLE AND HOLD						
t _{ADCSH}	ADC sample and hold time	f _{ADCCLK} = 16MHz		188		μs
C _{ADCIC}	ADC input capacitance	ADC MUX input		1.3		pF
INPUT VOLTAGE RANGE						
V _{ADCIN}	ADC input voltage range	ADC MUX input	0		V _{REFADC}	V
EMUX CLOCK SPEED						
f _{EMUXCLK}	EMUX engine clock input				50	MHz

14 MEMORY SYSTEM

14.1 Features

- 32kB Embedded FLASH
 - 100,000 program/erase cycles
 - 10 years data retention
- 256B INFO Embedded FLASH
 - Device ID, calibration data
 -
- 8kB SRAM
 - 50MHz read/write
 - Data storage or code execution
- SWD code protection

14.2 Memory System Block Diagram

Figure 14-1 Memory System

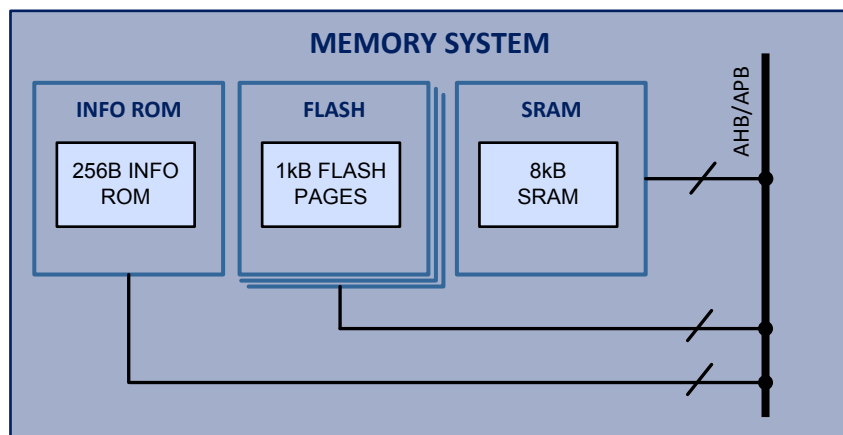

14.3 Functional Description

The PAC5232 has multiple banks of embedded FLASH memory, SRAM memory as well as peripheral control registers that are program-accessible in a flat memory map.

14.4 Program FLASH

The PAC5232 Memory Controller provides access to 32 1kB pages of main program FLASH for a total of 32kB of FLASH through the system AHB bus. Each page may be individually erased or written while the MCU is executing instructions from SRAM.

14.5 INFO FLASH

The PAC5232 Memory Controller contains a 256B read-only INFO memory. This memory contains device-specific information such as the device ID and calibration data for the device.

14.6 SRAM

The PAC5232 Memory Controller provides access to the 8kB SRAM for non-persistent data storage. The SRAM memory supports word (4B), half-word (2B) and byte addresses with aligned access.

The PAC5232 Memory Controller can read or write data from RAM up to 50MHz. This can be a benefit for time-critical applications. This memory can also be used for program execution when modifying the contents of FLASH.

For more information on the PAC5232 Memory Controller, see the PAC5232 User Guide.

14.7 SWD Protection

The PAC5232 allows the user to blow a fuse that prohibits use of the SWD serial interface.

This will prevent unauthorized users from accessing the contents of the device after customer production.

14.8 Electrical Characteristics

Table 14-1 Memory System Electrical Characteristics

(V_{CCIO} = 5V, T_A = -40°C to 105°C unless otherwise specified.)

SYMBOL	PARAMETER	CONDITIONS	MIN	TYP	MAX	UNIT
Embedded FLASH						
t _{READ,FLASH}	FLASH read time		40			ns
t _{WRITE,FLASH}	FLASH write time		20			µs
t _{PERASE,FLASH}	FLASH page erase time				10	ms
N _{PERASE,FLASH}	FLASH program/erase cycles			100k		cycles
t _{DR,FLASH}	FLASH data retention		10			years
SRAM						
t _{ACC,SRAM}	SRAM access time	Word (32-bits), aligned	20			ns

15 SYSTEM AND CLOCK CONTROL

15.1 Features

- Ring oscillator with 7.5MHz, 9.6MHz, 13.8MHz, and 25.7MHz settings
- High accuracy 1.25% trimmed 4MHz RC oscillator
- External clock input up to 40MHz
- PLL with 1MHz to 25 MHz input, and 3.5MHz to 100MHz output
- /1 to /8 clock divider for HCLK
- /1 to /128 clock divider for ACLK

15.2 Block Diagram

Figure 15-1 Clock Control System

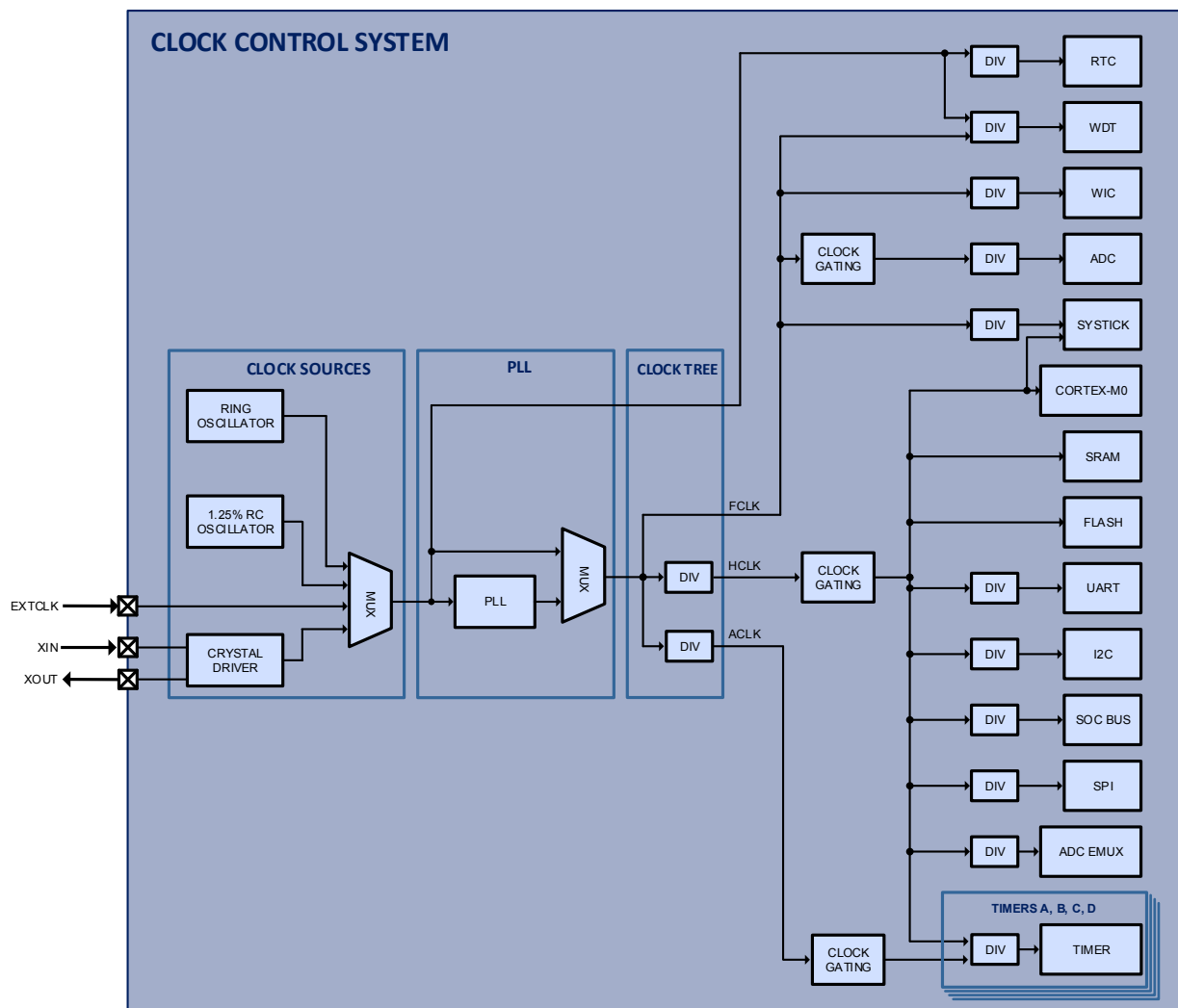

15.3 Functional Description

15.3.1 Free-Running Clock (FRCLK)

The free running clock (FRCLK) is generated from one of the 4 clock sources: ring oscillator, trimmed RC oscillator, crystal driver or external clock input. The FRCLK is used for the real-time clock (RTC), watchdog timer (WDT), input to the PLL, or FCLK source to clock the system in low power and sleep mode.

15.3.2 Auxiliary Clock (ACLK)

The auxiliary clock (ACLK) is derived from FCLK with a /1, /2, to /128 divider, and supplies the timer and dead-time blocks. It can be clocked faster or slower than HCLK and can go as high as 100MHz.

15.3.3 Clock Gating

The clock tree supports clock gating in deep-sleep mode for the timer block, ADC, SPI interface, I²C interface, UART interface, memory subsystem and the Arm® Cortex®-M0 itself.

15.3.4 Ring Oscillator (ROSC)

The integrated ring oscillator provides 4 different clocks with 7.5MHz, 9.6MHz, 13.8MHz, and 25.7MHz settings. After reset, the clock tree always defaults to this clock input with the lowest frequency setting.

15.3.5 Trimmed 4MHz RC Oscillator

The 1.25% trimmed 4MHz RC oscillator provides an accurate clock suitable for many applications. It is also used to derive the clock for the Multi-Mode Power Manager.

15.3.6 External Clock Input

The clock tree can be supplied with an external clock up to 40MHz.

15.3.7 PLL

The integrated PLL input clock is supplied by the FRCLK with an input frequency range of 1MHz to 25MHz. The PLL output frequency is adjustable from 3.5MHz to 100MHz.

15.4 Electrical Characteristics

Table 15-1 CCS Electrical Characteristics

(T_A = -40°C to 105°C unless otherwise specified.)

SYMBOL	PARAMETER	CONDITIONS	MIN	TYP	MAX	UNIT
Clock Tree (FRCLK, FCLK, ACLK, and HCLK)						
f _{FRCLK}	Free-running clock frequency				50	MHz
f _{FCLK}	Fast clock frequency				100	MHz
f _{ACLK}	Auxiliary clock frequency	After divider			100	MHz
f _{HCLK}	System clock frequency	After divider			50	MHz
Internal Oscillators						
f _{ROSC}	Ring oscillator frequency	Frequency setting = 11b		7.5		MHz
		Frequency setting = 10b		9.6		
		Frequency setting = 01b		13.8		
		Frequency setting = 00b		25.7		
f _{TRIM}	Trimmed RC oscillator frequency	T _A = 25°C	3.96	4	4.05	MHz
		T _A = -40°C to 105°C	3.92	4	4.08	MHz
	Trimmed RC oscillator clock jitter	T _A = -40°C to 105°C		0.5		%
External Clock Input (EXTCLK)						
f _{EXTCLK}	External Clock Input Frequency				40	MHz
t _{HIGH;EXTCLK}	External Clock High Time		10			ns
t _{LOW;EXTCLK}	External Clock Low Time		10			ns
V _{IH;EXTCLK}	External Clock Input high-level input voltage		2.1			V
V _{IL;EXTCLK}	External Clock Input low-level input voltage				0.825	V
PLL						
f _{INPLL}	PLL input frequency range		2		25	MHz
f _{OUTPLL}	PLL output frequency range		3.5		100	MHz
	PLL setting time			0.5		ms
	PLL period jitter	RMS		30		ps
		Peak to peak		±150		ps

16 ARM CORTEX®-M0 MCU CORE

16.1 Features

- Arm® Cortex®-M0 core
- Fast single-cycle 32-bit x 32-bit multiplier
- 24-bit SysTick timer
- Up to 50MHz operation
- Serial wire debug (SWD), with 4 break-point and 2 watch-point unit comparators
- Nested vectored interrupt controller (NVIC) with 25 external interrupts
- Wake-up interrupt controller (WIC) with GPIO, real-time clock (RTC) and watchdog timer (WDT) interrupts enabled
- Sleep and deep-sleep mode with clock gating

16.2 Block Diagram

Figure 16-1 Arm® Cortex®-M0 Microcontroller Core

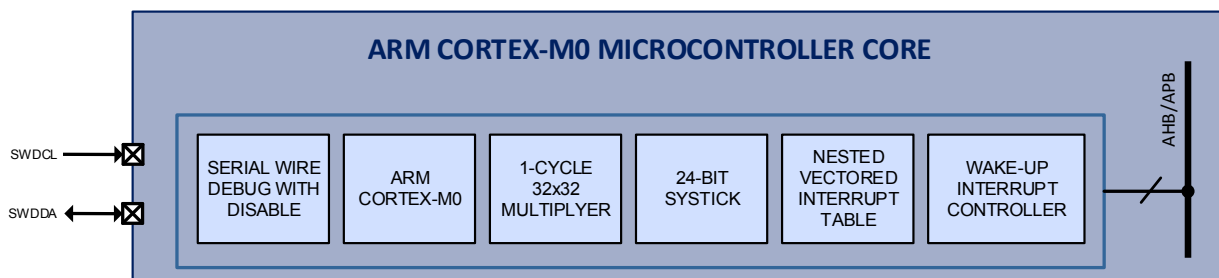

16.3 Functional Description

The Arm® Cortex®-M0 microcontroller core is configured for little endian operation and includes the fast single-cycle 32-bit multiplier and 24-bit SysTick timer and can operate at a frequency of up to 50MHz.

The microcontroller nested vectored interrupt controller (NVIC) supports 25 external interrupts for the device's peripherals and sub-systems. For low-latency interrupt processing, the NVIC also supports interrupt tail-chaining. The wake-up interrupt controller (WIC) is able to wake up the device from low-power modes using any GPIO interrupt, as well as from the RTC or WDT. The Arm® Cortex®-M0 supports both sleep and deep-sleep low-power modes. The deep-sleep mode supports clock gating to limit standby power even further.

Firmware debug support includes 4 break-point and 2 watch-point unit comparators using the serial wire debug (SWD) protocol. The serial wire debug mechanism can be disabled to prevent device access to the firmware in the field.

For more information on the detailed operation of the Microcontroller Core in the PAC5232, see the PAC5232 User Guide.

16.4 Electrical Characteristics

Table 16-1 MCU and Clock Control System Electrical Characteristics

(T_A = -40°C to 105°C unless otherwise specified.)

SYMBOL	PARAMETER	CONDITIONS	MIN	TYP	MAX	UNIT
f _{HCLK}	Microcontroller Clock	HCLK			50	MHz
I _{OP,VSYS}	V _{sys} operating supply current	f _{FRCLK} = f _{HCLK} = f _{ACLK} = ROSC 11b, PLL disabled, CPU halt; other clock sources, ADC, timers, and serial interfaces disabled		3.4		mA
		f _{FRCLK} = f _{HCLK} = f _{ACLK} = ROSC 10b, PLL disabled, CPU halt; other clock sources, ADC, timers, and serial interfaces disabled		4		
		f _{FRCLK} = f _{HCLK} = f _{ACLK} = ROSC 01b, PLL disabled, CPU halt; other clock sources, ADC, timers, and serial interfaces disabled		5.3		
		f _{FRCLK} = f _{HCLK} = f _{ACLK} = ROSC 00b, PLL disabled, CPU halt; other clock sources, ADC, timers, and serial interfaces disabled		9		
		f _{FRCLK} = f _{HCLK} = f _{ACLK} = CLKREF, PLL disabled, CPU halt; other clock sources, ADC, timers, and serial interfaces disabled		2.3		
		f _{FRCLK} = f _{HCLK} = f _{ACLK} = 10MHz XTAL, PLL disabled, CPU halt; other clock sources, ADC, timers, and serial interfaces disabled		4.5		
		f _{FRCLK} = 4MHz CLKREF, f _{HCLK} = 50MHz, f _{ACLK} = f _{OUTPLL} = 100MHz, CPU halt; other clock sources, ADC, timers, and serial interfaces disabled		23.3		
I _{Q,VCCIO}	V _{CCIO} quiescent supply current			0.02		mA

16.5 Typical Performance Characteristics

(V_{sys} = V_{CCIO} = 5V, T_A = -40°C to 105°C unless otherwise specified.)

Figure 16-2 MCU Performance Characteristics

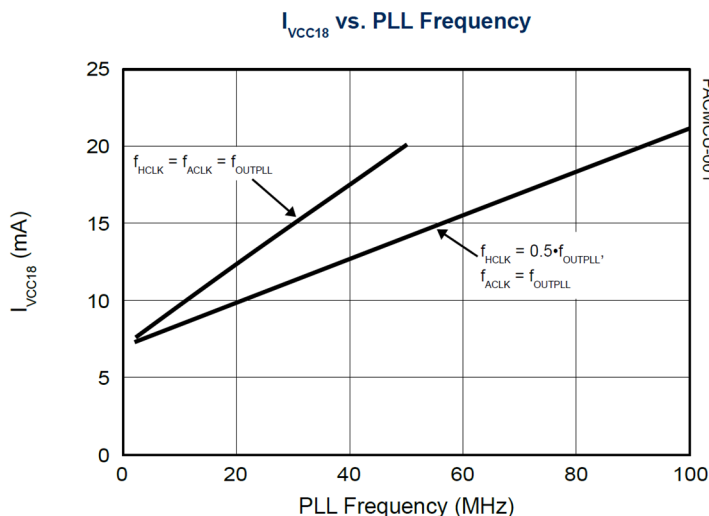

17 IO CONTROLLER

17.1 Features

- 5V-compliant I/O PAX, PDx, PEx
- 3.3V-compliant I/O PCx
- Configurable drive strength on PAX, PDx, PEx
- Configurable pull-up or pull-down on PAX, PDx, PEx

17.2 Block Diagram

Figure 17-1 IO Controller Block Diagram

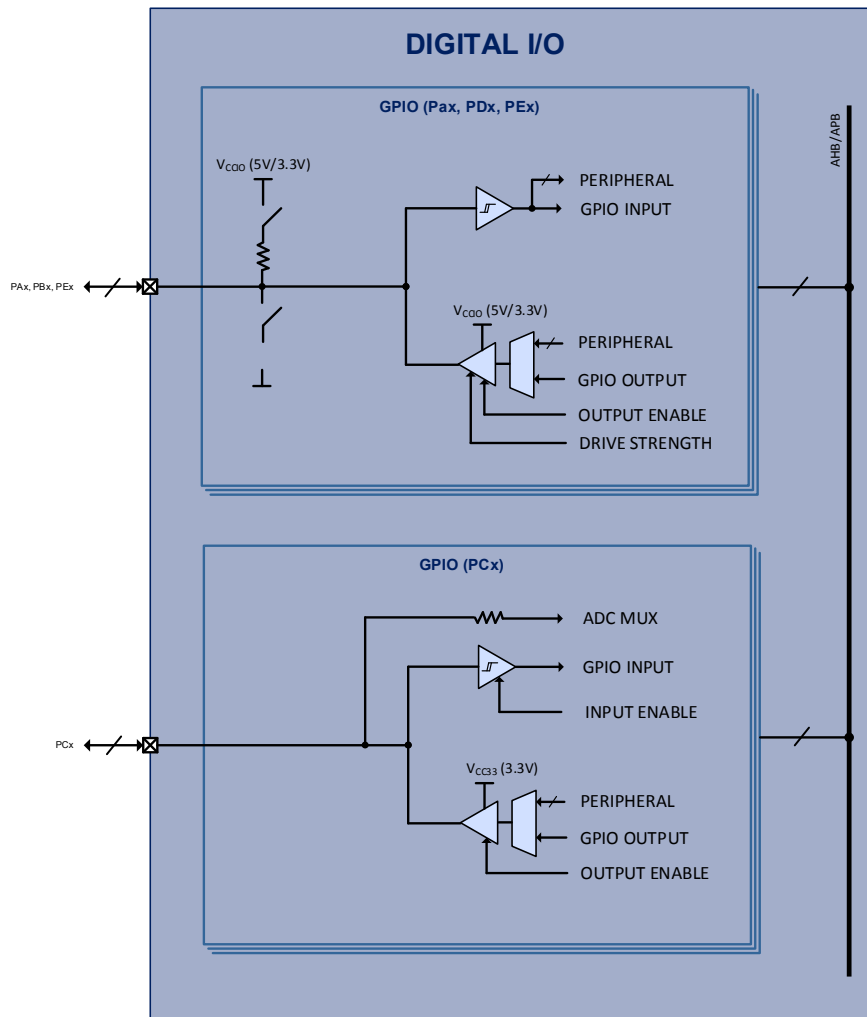

17.3 Functional Description

The PAC® can support up to 4 ports with 8 I/Os each from PAX, PCx, PDx, and PEx, in addition to the I/Os on the analog front end. All PAX, PCx, PDx, and PEx ports have interrupt capability with configurable interrupt edge.

PAX, PDx, and PEx I/Os use V_{CCIO} as the I/O supply voltage that is set to 3.3V. To drive these IOs t 5V, the user may short VCCIO and VSYS on the PCB, then 5V will be the supply for these IOs.

The drive current can be configured as 8mA or 16mA. They also support weak pull-up and pull-down to save external components.

PCx uses V_{CC33} as its I/O supply voltage. The drive current is fixed to 8mA. PC0 to PC5 are also associated with analog inputs AD0 to AD5 to the ADC.

17.4 GPIO Current Injection

Under normal operation, there should not be current injected into the GPIOs on the device due to the GPIO voltage below ground or above the GPIO supply⁶. Current will be injected into the GPIO when the GPIO pin voltage is less than -0.3V or when greater than GPIO supply + 0.3V.

In order provide a robust solution when this situation occurs, the PAC52XX family of products allows a small amount of injected current into the GPIO pins, to avoid excessive leakage or device damage.

For information on the GPIO current injection thresholds, see the absolute maximum parameters for this device.

Sustained operation with the GPIO pin voltage greater than the GPIO supply or when the GPIO pin voltage is less than -0.3V may result in reduced lifetime of the device. GPIO current injection should only be a temporary condition.

⁶ VCC33 is the supply for any PC GPIO pin and VCCIO is the supply for any other GPIO pins.

17.5 Electrical Characteristics

Table 17-1 IO Controller Electrical Characteristics

($V_{SYS} = V_{CCIO} = 5V$, and $T_A = -40^{\circ}C$ to $105^{\circ}C$ unless otherwise specified.)

SYMBOL	PARAMETER	CONDITIONS	MIN	TYP	MAX	UNIT
PAx, PDx, PEx (5V Operation)						
V_{IH}	High-level input voltage		3			V
V_{IL}	Low-level input voltage				0.8	V
I_{OL}	Low-level output sink current (Limited by $I_{V_{SYS}}$)	$V_{OL} = 0.4V$	Drive Strength = 0b	7		mA
			Drive Strength = 1b	15		
I_{OH}	High-level output source current (Limited by $I_{V_{SYS}}$)	$V_{OH} = 2.4V$	Drive Strength = 0b		-7	mA
			Drive Strength = 1b		-15	
R_{PU}	Weak pull-up resistance	$V_{CCIO} = 3.3V$, pull-up enabled	47	74	104	k Ω
R_{PD}	Weak pull-down resistance	$V_{CCIO} = 3.3V$, pull-down enabled	50	84	121	k Ω
I_{IL}	Input leakage current		-10		10	μA
PCx (3.3V Operation)						
V_{IH}	High-level input voltage	$V_{CC33} = 3.3V$	2			V
V_{IL}	Low-level input voltage	$V_{CC33} = 3.3V$			0.8	V
I_{OL}	Low-level output sink current	$V_{CC33} = 3.3V$, $V_{OL} = 0.4V$	7			mA
I_{OH}	High-level output source current	$V_{CC33} = 3.3V$, $V_{OH} = 2.4V$			-7	mA
I_{IL}	Input leakage current	$T_A = 125^{\circ}C$	-10	0	10	μA

18 SERIAL INTERFACE

18.1 Block Diagram

Figure 18-1 Serial Interface Block Diagram

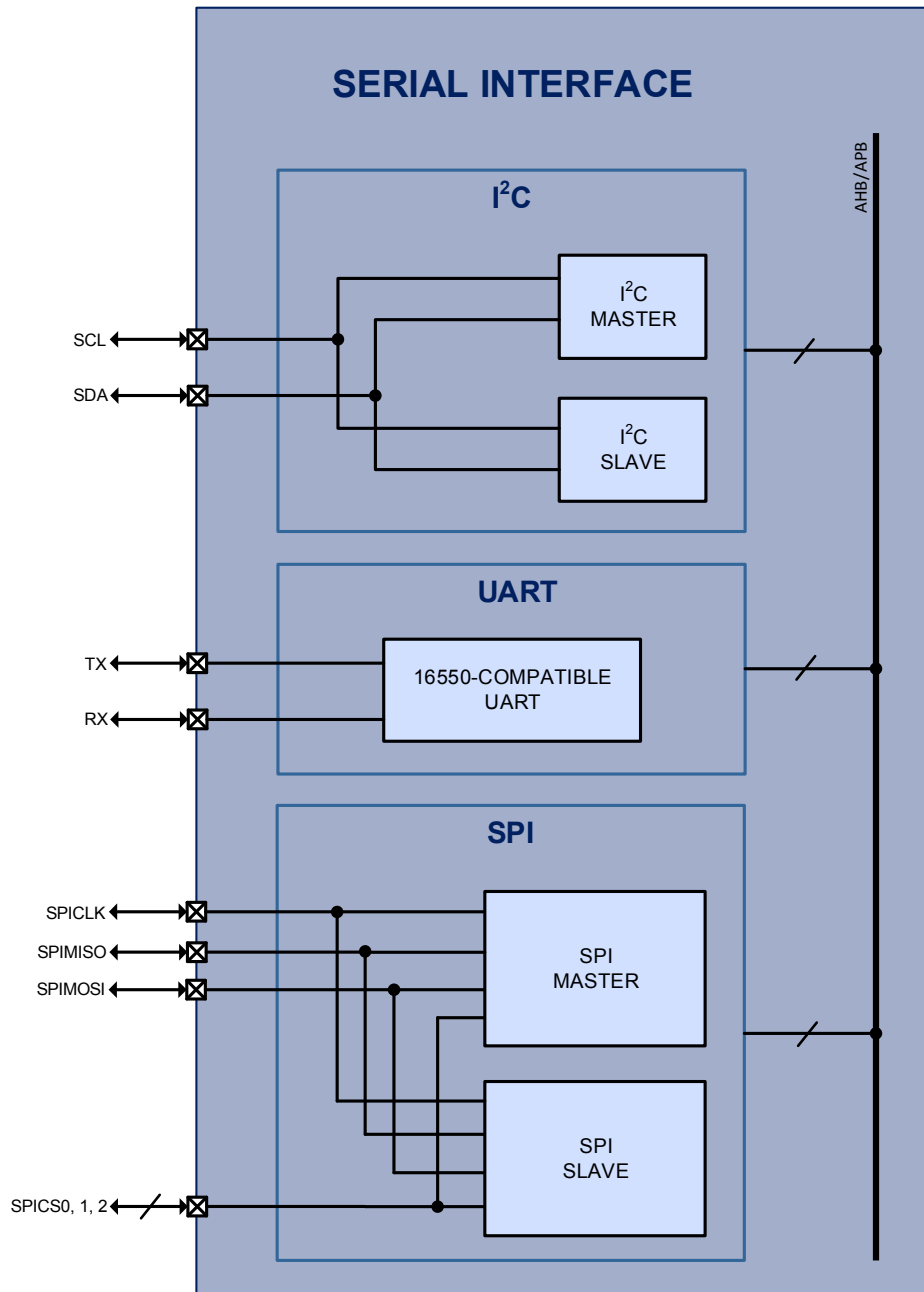

18.2 Functional Description

The PAC5232 has up to three serial interfaces: I²C, UART and SPI.

18.3 I²C Controller

The I²C controller is a configurable peripheral that can support various modes of operation:

- I²C master operation
 - Normal mode (100kHz), fast mode (400kHz), or fast mode plus (1MHz)
 - Single and multi-master
 - Synchronization (multi-master)
 - Arbitration (multi-master)
 - 7-bit or 10-bit slave addressing
- I²C slave operation
 - Normal mode (100kHz), fast mode (400kHz), or fast mode plus (1MHz)
 - Clock stretching
 - 7-bit or 10-bit slave addressing

The I²C peripheral may operate either by polling, or can be configured to be interrupt driven for both receive and transmit data.

18.4 UART Controller

The UART peripheral is a configurable peripheral that can support various features and modes of operation:

- Programmable clock selection
- National Instruments PC16550D compatible
- 16-deep transmit and receive FIFO and fractional clock divisor
- Up to 3.125Mbps communication speed (with HCLK = 50MHz)

The UART peripheral may operate either by polling, or can be configured to be interrupt driven for both receive and transmit data.

18.5 SPI Controller

The device contains an SPI controller that can each be used in either master or slave operation, with the following features:

- SPI master operation
 - Control of up to three different SPI slaves
 - Operation up to 25MHz
 - Flexible multiple transmit mode for variable-size SPI data with user-defined chip-select behavior
 - Chip select “shaping” through programmable additional delay for chip-select setup, hold and wait time
 - for back-to-back transfers

- SPI master or slave operation
 - Supports clock phase and polarity control
 - Data transmission/reception can be on 8-, 16-, 24- or 32-bit boundary
 - Selectable data bit ordering (LSB or MSB first)
 - Programmable chip select polarity
 - Selectable “auto-retransmit” mode

The SPI peripheral may operate either by polling, or can be configured to be interrupt driven for both receive and transmit data.

18.6 Dynamic Characteristics

Table 18-1 Serial Interface Dynamic Characteristics

(V_{sys} = V_{CCIO} = 5V, and T_A = -40°C to 105°C unless otherwise specified.)

SYMBOL	PARAMETER	CONDITIONS	MIN	TYP	MAX	UNIT
I²C						
f _{I2CCLK}	I ² C input clock frequency	Standard mode (100kHz)	2.8			MHz
		Full-speed mode (400kHz)	2.8			MHz
		Fast mode (1MHz)	6.14			MHz
UART						
f _{UARTCLK}	USART input clock frequency				f _{HCLK} /16	MHz
	UART baud rate	f _{HCLK} = 50MHz			3.125	Mbps
SPI						
f _{SPICLK}	USART input clock frequency	Master mode			f _{HCLK} /2	MHz
		Slave mode			f _{HCLK} /2	MHz

Table 18-2 I²C Dynamic Characteristics

(V_{SYS} = V_{CCIO} = 5V, and T_A = -40°C to 105°C unless otherwise specified.)

SYMBOL	PARAMETER	CONDITIONS	MIN	TYP	MAX	UNIT
f _{SCL}	SCL clock frequency	Standard mode	0		100	kHz
		Full-speed mode	0		400	kHz
		Fast mode	0		1000	kHz
t _{LOW}	SCL clock low	Standard mode	4.7			μs
		Full-speed mode	1.3			μs
		Fast mode	0.5			μs
t _{HIGH}	SCL clock high	Standard mode	4.0			μs
		Full-speed mode	0.6			μs
		Fast mode	0.26			μs
t _{HD,STA}	Hold time for a repeated START condition	Standard mode	4.0			μs
		Full-speed mode	0.6			μs
		Fast mode	0.26			μs
t _{SU,STA}	Set-up time for a repeated START condition	Standard mode	4.7			μs
		Full-speed mode	0.6			μs
		Fast mode	0.26			μs
t _{HD,DAT}	Data hold time	Standard mode	0		3.45	μs
		Full-speed mode	0		0.9	μs
		Fast mode	0			μs
t _{SU,DAT}	Data setup time	Standard mode	250			ns
		Full-speed mode	100			ns
		Fast mode	50			ns
t _{SU,STO}	Set-up time for STOP condition	Standard mode	4.0			μs
		Full-speed mode	0.6			μs
		Fast mode	0.26			μs
t _{BUF}	Bus free time between a STOP and START condition	Standard mode	4.7			μs
		Full-speed mode	1.3			μs
		Fast mode	0.5			μs
t _r	Rise time for SDA and SCL	Standard mode			1000	ns
		Full-speed mode	20		300	ns
		Fast mode			120	ns
t _f	Fall time for SDA and SCL	Standard mode			300	ns
		Full-speed mode			300	ns
		Fast mode			120	ns
C _b	Capacitive load for each bus line	Standard mode, full-speed mode			400	pF
		Fast mode			550	pF

Figure 18-2 I²C Timing Diagram

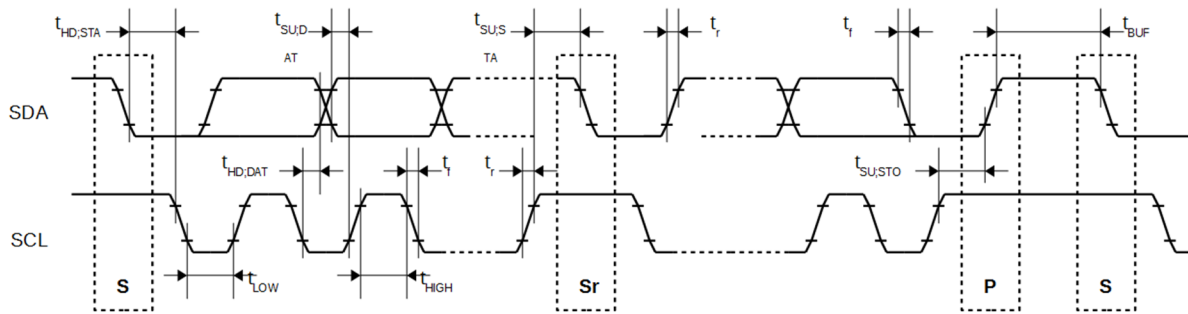
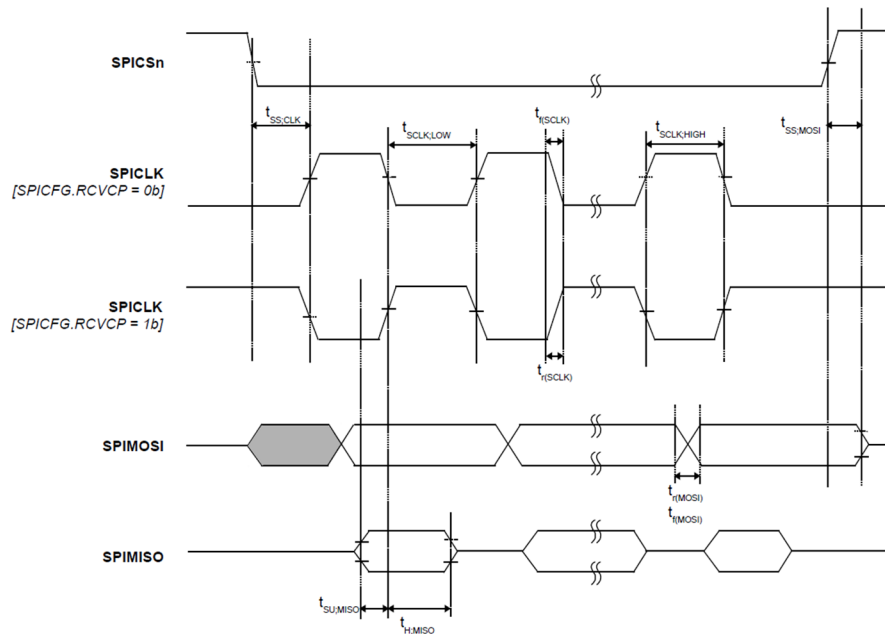

Table 18-3 SPI Dynamic Characteristics

($V_{SYS} = V_{CCIO} = 5V$, and $T_A = -40^{\circ}C$ to $105^{\circ}C$ unless otherwise specified.)

SYMBOL	PARAMETER	CONDITIONS	MIN	TYP	MAX	UNIT
$t_{SCLK;HIGH}$	SPICLK Input High Time	SPICLK = 25MHz	30			ns
$t_{SCLK;LOW}$	SPICLK Input low Time		30			ns
$t_{SS;SCLK}$	SPICSn to SPICLK Time		120			ns
$t_{SS;MOSI}$	SPICSn to SPIMISO High-impedance time		10		50	ns
$t_{r(SCLK)}$	SPICLK Rise Time			10	25	ns
$t_{f(SCLK)}$	SPICLK Fall Time			10	25	ns
$t_{r(MOSI)}$	SPIMOSI Rise Time			10	25	ns
$t_{f(MOSI)}$	SPIMOSI Fall Time			10	25	ns
$t_{r(MISO)}$	SPIMISO Rise Time			10	25	ns
$t_{f(MISO)}$	SPIMISO Fall Time			10 <td 25	ns	
$t_{SU;MISO}$	SPIMISO Setup Time		20			ns
$t_{H;MISO}$	SPIMISO Hold Time		20			ns

Figure 18-3 SPI Timing Diagram



19 TIMERS

19.1 Block Diagram

Figure 19-1 PWM Timers Block Diagram

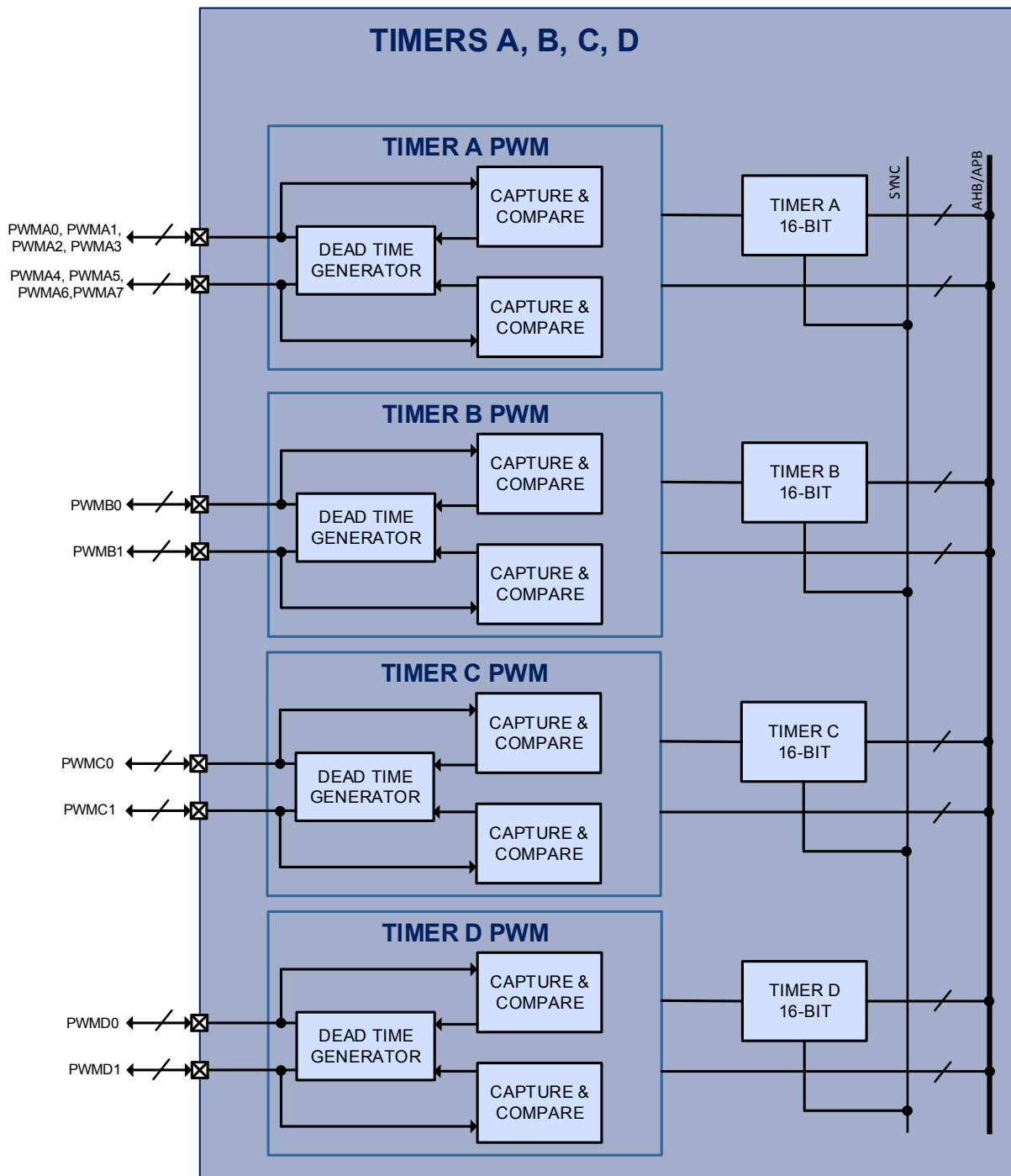

Figure 19-2 SOC Bus Watchdog and Wake-Up Timer

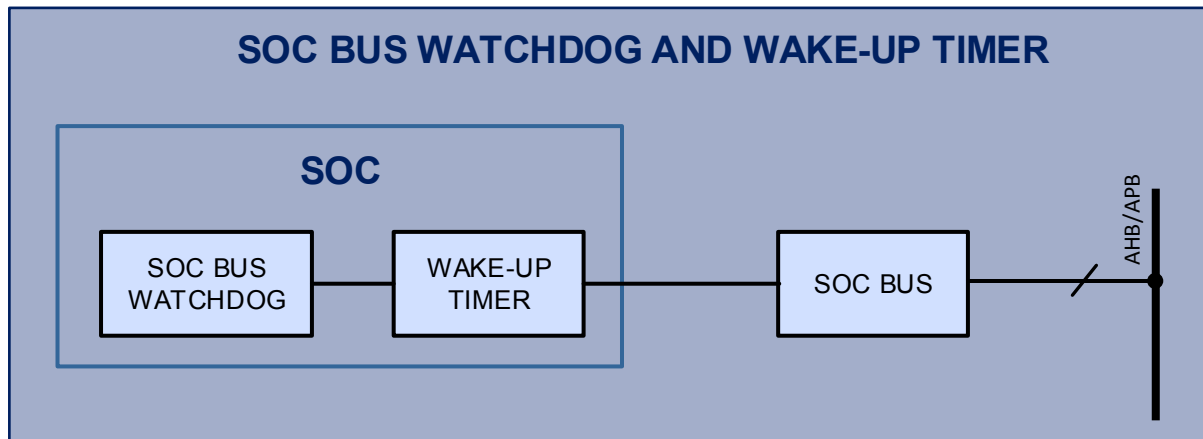
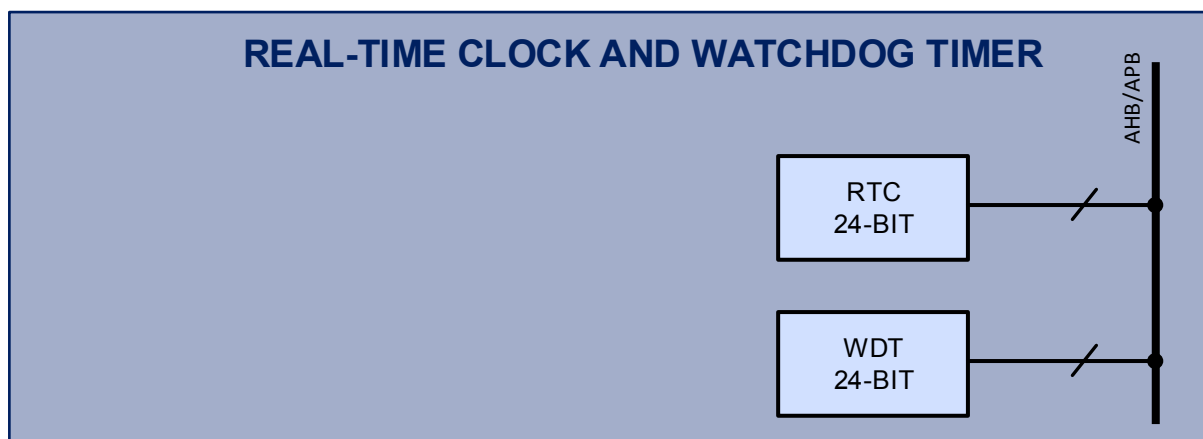

Figure 19-3 Real-Time Clock and Watchdog Timer



19.2 Functional Description

The device includes 9 timers: timer A, timer B, timer C, timer D, watchdog timer 1 (WDT), watchdog timer 2, wake-up timer, real-time clock (RTC), and SysTick timer. The device supports up to 14 different PWM signals and has up to 7 dead-time controllers. Timers A, B, C and D can be concatenated to synchronize to a single clock and start/stop signal for applications that require a synchronized timer period between timers.

19.2.1 Timer A

Timer A is a general purpose 16-bit timer with 8 PWM/capture and compare units. It has 4 pairs of PWM signals going into 4 dead-time controllers. Timer A can be concatenated with timers B, C, and D to synchronize the PWM/capture and compare units. It can use either ACLK or HCLK as clock input with an additional clock divider from /1 to /128.

19.2.2 Timer B

Timer B is a general purpose 16-bit timer with 2 PWM/capture and compare units. It has one pair of PWM signals going into one dead-time controller, as well as 2 additional compare units that can be used for additional system time bases for interrupts. Timer B can be concatenated with timers A, C, and D to synchronize the PWM/capture and compare units. It can use either ACLK or HCLK as clock input with an additional clock divider from /1 to /128.

19.2.3 Timer C

Timer C is a general purpose 16-bit timer with 2 PWM/capture and compare units. It has one pair of PWM signals going into one dead-time controller. Timer C can be concatenated with timers A, B, and D to synchronize the PWM/capture and compare units. It can use either ACLK or HCLK as clock input with an additional clock divider from /1 to /128.

19.2.4 Timer D

Timer D is a general purpose 16-bit timer with 2 PWM/capture and compare units. It has one pair of PWM signals going into one dead-time controller. Timer D can be concatenated with timers A, B, and C to synchronize the PWM/capture and compare units. It can use either ACLK or HCLK as clock input with an additional clock divider from /1 to /128.

19.2.5 Watchdog Timer

The 24-bit watchdog timer (WDT) can be used for long time period measurements or periodic wake up from sleep mode.

The watchdog timer can be used as a system watchdog, or as an interval timer, or both. The watchdog timer can use either FRCLK or FCLK as clock input with an additional clock divider from /2 to /65536.

19.2.6 SOC Bus Watchdog Timer

The watchdog timer 2 is used to monitor internal SOC Bus communication. It will trigger device reset if there is no SOC Bus communication to the AFE for 4s or 8s.

19.2.7 Wake-Up Timer

The wake-up timer can be used for very low power hibernate and sleep modes to wake up the micro controller periodically.

It can be configured to be 125ms, 250ms, 500ms, 1s, 2s, 4, or 8s.

19.2.8 Real-Time Clock

The 24-bit real-time clock (RTC) can be used for time measurements when an accurate clock source is used. This timer can also be used for periodic wake up from sleep mode. The RTC uses FRCLK as clock input with an additional clock divider from /2 to /65536.

20 THERMAL CHARACTERISTICS

Table 20-1 Thermal Characteristics

PARAMETER	VALUE	UNIT
Operating ambient temperature range	-40 to 105	°C
Operating junction temperature range	-40 to 125	°C
Storage temperature range	-55 to 150	°C
Lead temperature (Soldering, 10 seconds)	300	°C
Junction-to-case thermal resistance (Θ_{JC})	2.897	°C/W
Junction-to-ambient thermal resistance (Θ_{JA})	23.36	°C/W

21 APPLICATION EXAMPLES

The following simplified diagram shows an example of a single-motor, low-voltage application using the PAC5232 device.

Figure 21-1 3-Phase Motor Using PAC5232 (Simplified Diagram)

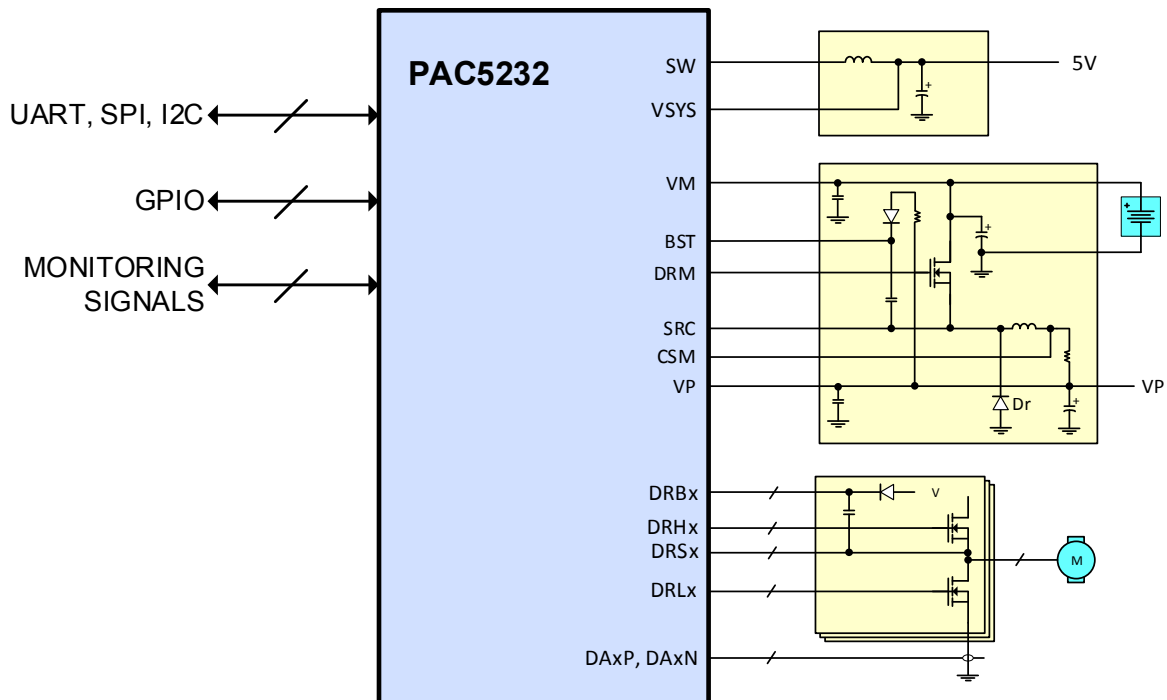

22 PACKAGE OUTLINE AND DIMENSIONS

22.1 51L 8x8 QFN Package Outline and Dimensions

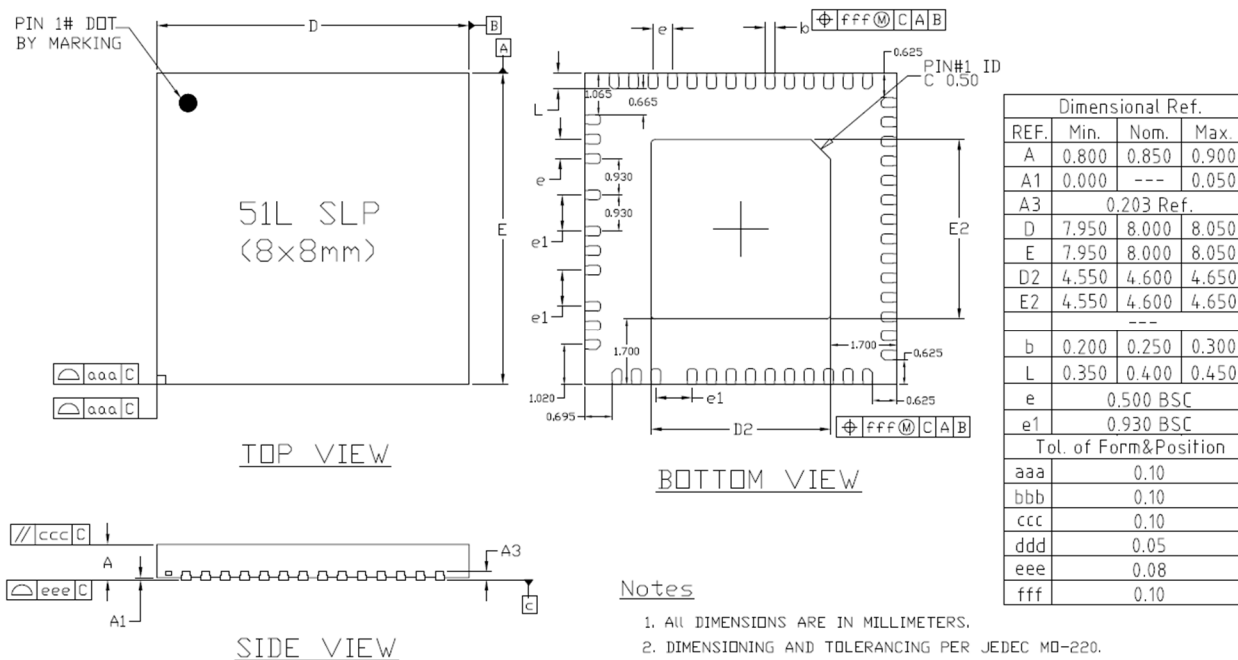

Contact Information

For the latest specifications, additional product information, worldwide sales and distribution locations:

Web: www.qorvo.com

Tel: 1-844-890-8163

Email: customer.support@qorvo.com

For technical questions and application information:

Email: appsupport@qorvo.com

Important Notice

The information contained herein is believed to be reliable; however, Qorvo makes no warranties regarding the information contained herein and assumes no responsibility or liability whatsoever for the use of the information contained herein. All information contained herein is subject to change without notice. Customers should obtain and verify the latest relevant information before placing orders for Qorvo products. The information contained herein or any use of such information does not grant, explicitly or implicitly, to any party any patent rights, licenses, or any other intellectual property rights, whether with regard to such information itself or anything described by such information. **THIS INFORMATION DOES NOT CONSTITUTE A WARRANTY WITH RESPECT TO THE PRODUCTS DESCRIBED HEREIN, AND QORVO HEREBY DISCLAIMS ANY AND ALL WARRANTIES WITH RESPECT TO SUCH PRODUCTS WHETHER EXPRESS OR IMPLIED BY LAW, COURSE OF DEALING, COURSE OF PERFORMANCE, USAGE OF TRADE OR OTHERWISE, INCLUDING THE IMPLIED WARRANTIES OF MERCHANTABILITY AND FITNESS FOR A PARTICULAR PURPOSE.**

Without limiting the generality of the foregoing, Qorvo products are not warranted or authorized for use as critical components in medical, life-saving, or life-sustaining applications, or other applications where a failure would reasonably be expected to cause severe personal injury or death.

Copyright 2019 © Qorvo, Inc. | Qorvo®, Active-Semi®, Power Application Controller®, Multi-Mode Power Manager™, Configurable Analog Front End™ and Application Specific Power Drivers™ are trademarks of Qorvo, Inc.

Arm® and Cortex® are registered trademarks of Arm Limited. All referenced brands and trademarks are the property of their respective owners.