

Product Overview

QPQ1214 is a SAW based triplexer filter module. This module was specifically designed in a 4x5 mm package. It is comprised of three SAW dies and passive SMT components.

QPQ1214 exhibits industry leading mid-band rejections for LTE bands 12 and 13 based on utilization of Qorvo's proprietary temperature compensated process technology that reduces the temperature coefficient of frequency for SAW devices by almost 50%.

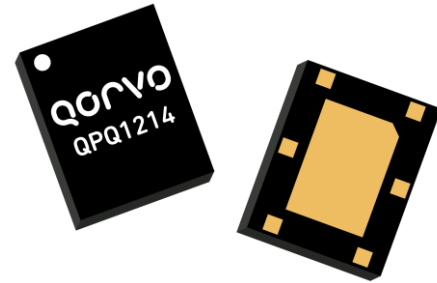

6 Pin 4x5 mm leadless SMT Package

Functional Block Diagram

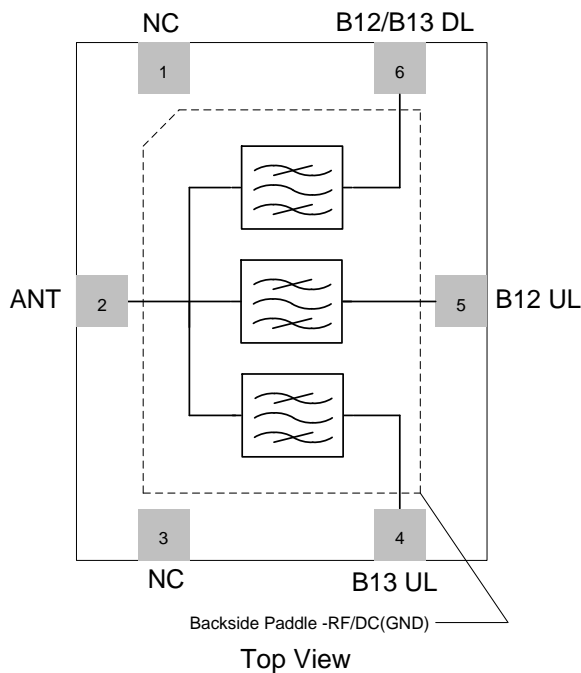

Key Features

- Temperature compensated SAW
- Usable Bandwidth 17 MHz at 707.5 MHz
- Usable Bandwidth 27 MHz at 742.5 MHz
- Usable Bandwidth 11 MHz at 782.0 MHz
- Internally Matched for 50 Ohm Operation
- Small Size: 4.00 x 5.00 x 1.06 mm
- Surface Mount Device
- RoHS compliant, Pb-free

Applications

- Networks Repeater
- Base station infrastructure
- Wireless devices
- Cellular small cells

Pin Configuration

Pin No.	Label	Function
1, 3	NC	No Connection
2	ANT	Antenna Port
4	B13 UL	Band 13 Up Link Port
5	B12 UL	Band 12 Up Link Port
6	B12/B13 DL	Band 12 and 13 Down Link Port

Ordering Information

Part No.	Description
QPQ1214TR13	2500pcs on a 13" reel
QPQ1214EVB	Evaluation board

Absolute Maximum Ratings

Parameter	Rating
Storage Temperature	-40 to 85°C
Operation Temperature	+25 to 70°C

Exceeding any one or a combination of the Absolute Maximum Rating conditions may cause permanent damage to the device. Extended application of Absolute Maximum Rating conditions to the device may reduce device reliability.

Minimum Lifetime Ratings

Conditions	Rating
RF Input Power ⁽¹⁾ (B13UL), Pin 4	10,000 Hrs
RF Input Power ⁽¹⁾ (B12UL), Pin 5	10,000 Hrs
RF Input Power ⁽¹⁾ (B12/B13DL), Pin 6	10,000 Hrs

⁽¹⁾ Input Power: CW, 30 dBm, @ +55 °C

Electrical Specifications ⁽¹⁾ ⁽²⁾ ⁽³⁾ – B12 UL (699-716MHz) BPF

Operating Temperature Range: +25 to +70°C.

Parameter	Conditions	Min	Typ. ⁽⁴⁾	Max	Units
Center Frequency [fo]			707.5		MHz
Insertion Loss	699 MHz – 716 MHz	-	-	3.0	dB
Amplitude Variation ⁽¹⁾	699 MHz – 716 MHz	-	1.0	1.5	dB
Absolute Attenuation ⁽⁵⁾	10 MHz – 500 MHz	30	35	-	dB
	722.5 MHz – 729 MHz ⁽⁶⁾	18	22	-	dB
	729 MHz – 787 MHz	38	43	-	dB
	787 MHz – 894 MHz	30	35	-	dB
	1400 MHz – 2155 MHz	30	37	-	dB
Input / Output Return Loss	699 MHz – 716 MHz	10	13	-	dB
Temperature Coefficient		-	-25	-	ppm/°C
Load/Source Impedance		-	50	-	Ω

Notes:

1. All specifications are based on the Qorvo schematic shown on page 10.
2. In production, devices will be tested at room temperature to a guard banded specification to ensure compliance over temperature.
3. Electrical margin has been built into the design to account for variations due to temperature drift and manufacturing tolerances.
4. Typical values are based on average measurements at room temperature.
5. Attenuation is referenced to ZERO dB
6. Describes the absolute attenuation over the defined frequency range at +25°C only

Electrical Specifications ^{(1) (2) (3)} – B12/B13 DL (729-756MHz) BPF

Operating Temperature Range: +25 to +70°C.

Parameter	Conditions	Min	Typ. ⁽⁴⁾	Max	Units
Center Frequency [fo]			742.5		MHz
Insertion Loss	729 MHz – 756 MHz	-	-	3.0	dB
Amplitude Variation	729 MHz – 756 MHz	-	1.0	1.5	dB
Absolute Attenuation ⁽⁵⁾	10 MHz – 699 MHz	30	35	-	dB
	699 MHz – 716 MHz	35	39	-	dB
	716 MHz – 722.5 MHz ⁽⁶⁾	18	22	-	dB
	766.5 MHz – 777 MHz ⁽⁶⁾	20	30	-	dB
	777 MHz – 787 MHz	35	40	-	dB
	824 MHz – 894 MHz	25	30	-	dB
	1400 MHz – 2155 MHz	30	42	-	dB
	2184 MHz – 2271 MHz	35	47	-	dB
Input / Output Return Loss	729 MHz – 756 MHz	10	13	-	dB
Temperature Coefficient		-	-25	-	ppm/°C
Load/Source Impedance		-	50	-	Ω

Notes:

1. All specifications are based on the Qorvo schematic shown on page 10.
2. In production, devices will be tested at room temperature to a guard banded specification to ensure compliance over temperature.
3. Electrical margin has been built into the design to account for variations due to temperature drift and manufacturing tolerances.
4. Typical values are based on average measurements at room temperature.
5. Attenuation is referenced to ZERO dB
6. Describes the absolute attenuation over the defined frequency range at +25°C only

Electrical Specifications ^{(1) (2) (3)} – B13UL (777-787MHz) BPF

Operating Temperature Range: +25 to +70°C.

Parameter	Conditions	Min	Typ. ⁽⁴⁾	Max	Units
Center Frequency [fo]			782.0		MHz
Insertion Loss	777 MHz – 787 MHz	-	-	3.0	dB
Amplitude Variation	777 MHz – 787 MHz	-	0.5	0.9	dB
Absolute Attenuation ⁽⁵⁾	10 MHz – 500 MHz	35	40	-	dB
	699 MHz – 756 MHz	38	42	-	dB
	756 MHz – 766.5 MHz ⁽⁶⁾	20	34	-	dB
	817 MHz – 894 MHz	35	40	-	dB
	1400 MHz – 1600 MHz	35	39	-	dB
	1600 MHz – 2155 MHz	25	30	-	dB
Input / Output Return Loss	777 MHz – 787 MHz	10	13	-	dB
Temperature Coefficient		-	-25	-	ppm/°C
Load/Source Impedance		-	50	-	Ω

Notes:

1. All specifications are based on the Qorvo schematic shown on page 10.
2. In production, devices will be tested at room temperature to a guard banded specification to ensure compliance over temperature.
3. Electrical margin has been built into the design to account for variations due to temperature drift and manufacturing tolerances.
4. Typical values are based on average measurements at room temperature.
5. Attenuation is referenced to ZERO dB
6. Describes the absolute attenuation over the defined frequency range at +25°C only

Electrical Specifications ⁽¹⁾ ⁽²⁾ ⁽³⁾ – Output Isolation

Operating Temperature Range: +25 to +70°C.

Parameter	Conditions	Min	Typ. ⁽⁴⁾	Max	Units
B12UL - B12/B13 DL	699 MHz – 716 MHz	42	44	-	dB
	716 MHz – 729 MHz	43	45	-	
	729 MHz – 756 MHz	43	45	-	
	756 MHz – 777 MHz	40	43	-	
	777 MHz – 787 MHz	45	50	-	
B12UL – B13UL	699 MHz – 716 MHz	40	45	-	dB
	716 MHz – 729 MHz	40	45	-	
	729 MHz – 756 MHz	42	45	-	
	756 MHz – 777 MHz	39	42	-	
	777 MHz – 787 MHz	38	41	-	
B12/B13 DL – B13UL	699 MHz – 716 MHz	50	54	-	dB
	716 MHz – 729 MHz	45	48	-	
	729 MHz – 756 MHz	45	48	-	
	756 MHz – 777 MHz	45	48	-	
	777 MHz – 787 MHz	45	48	-	

Notes:

1. All specifications are based on the Qorvo schematic shown on page 10.
2. In production, devices will be tested at room temperature to a guard banded specification to ensure compliance over temperature.
3. Electrical margin has been built into the design to account for variations due to temperature drift and manufacturing tolerances.
4. Typical values are based on average measurements at room temperature.

Performance Plots

Test conditions unless otherwise noted: Temp= +25°C

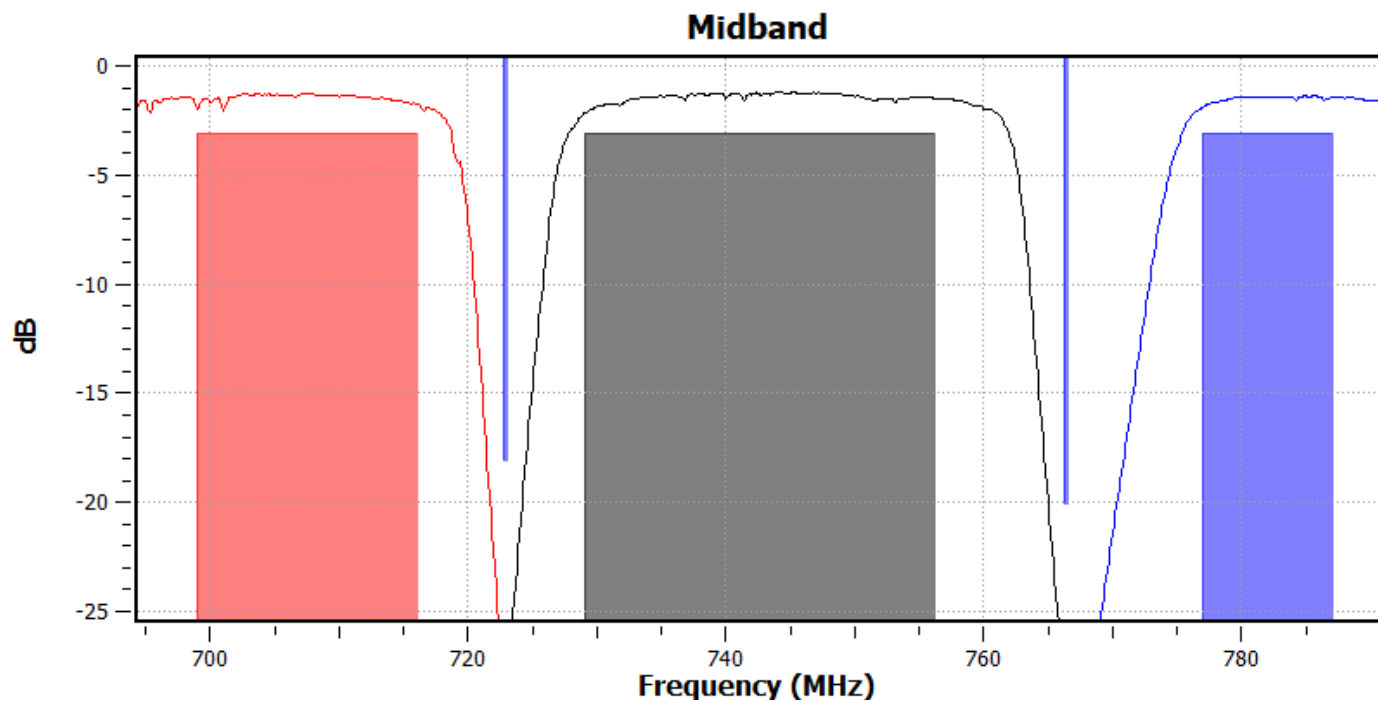
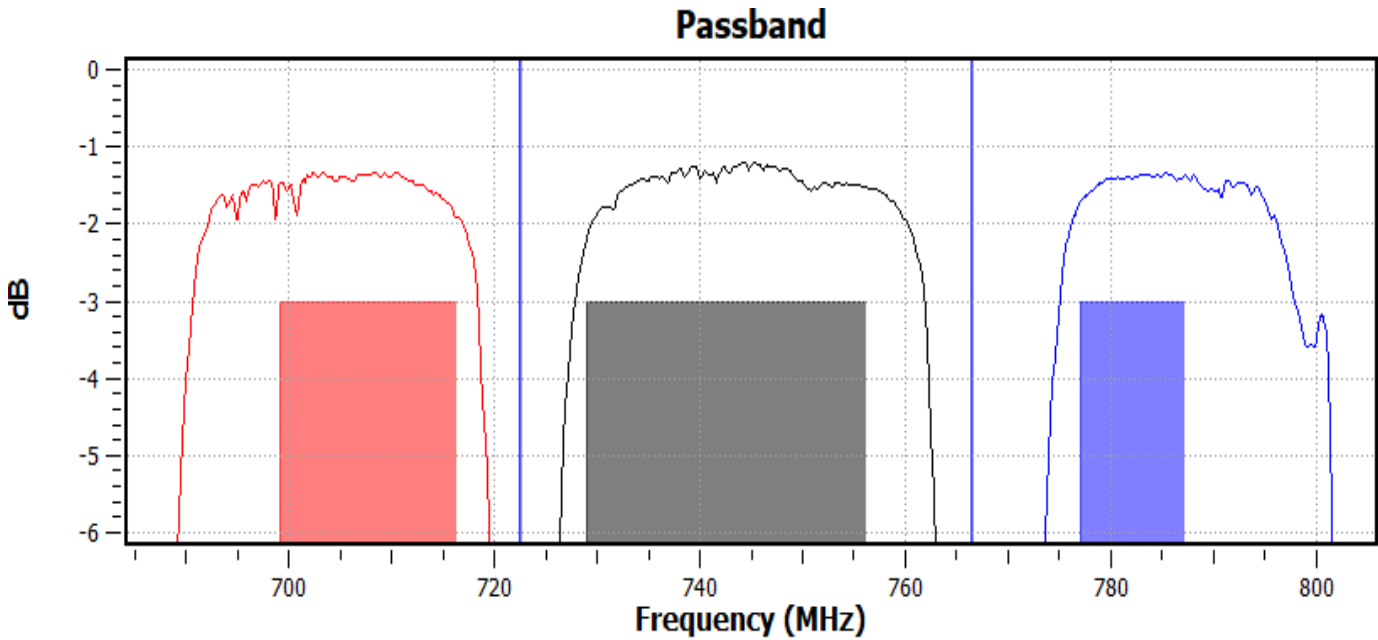

Performance Plots

Test conditions unless otherwise noted: Temp= +25°C

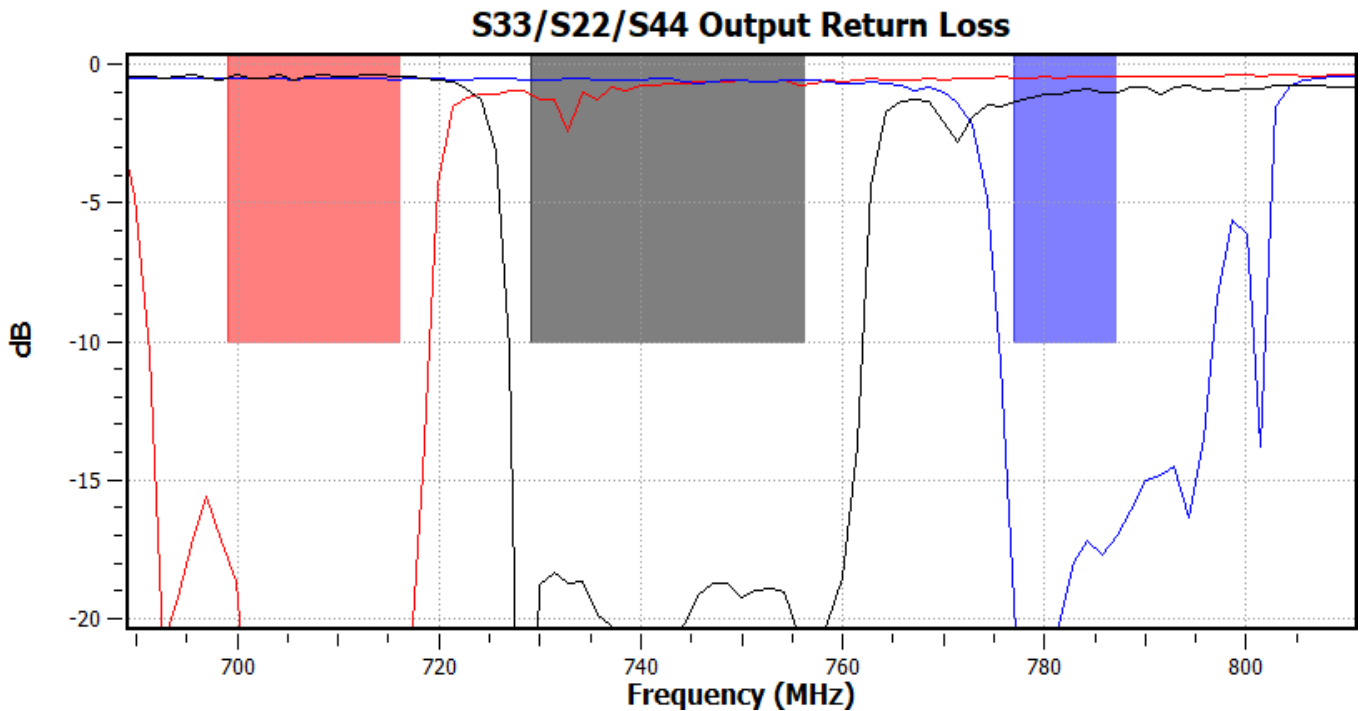
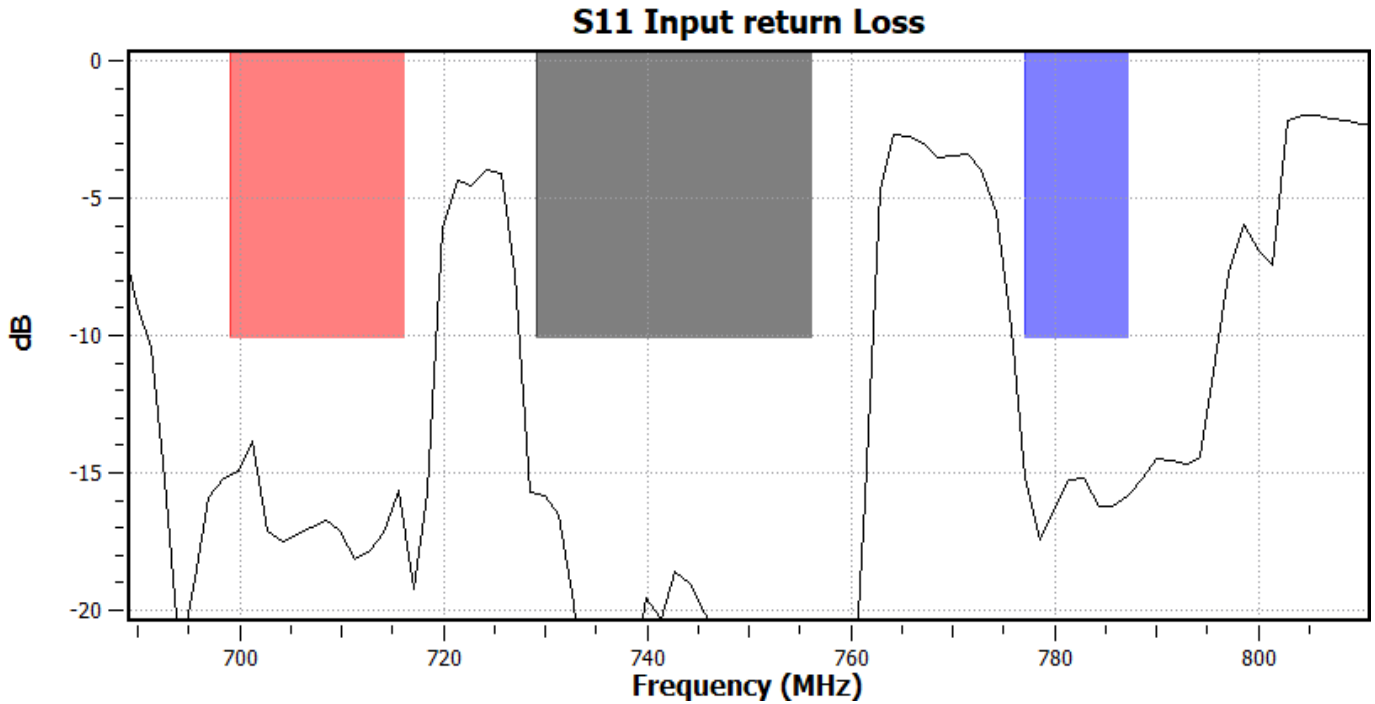

Performance Plots

Test conditions unless otherwise noted: Temp= +25°C

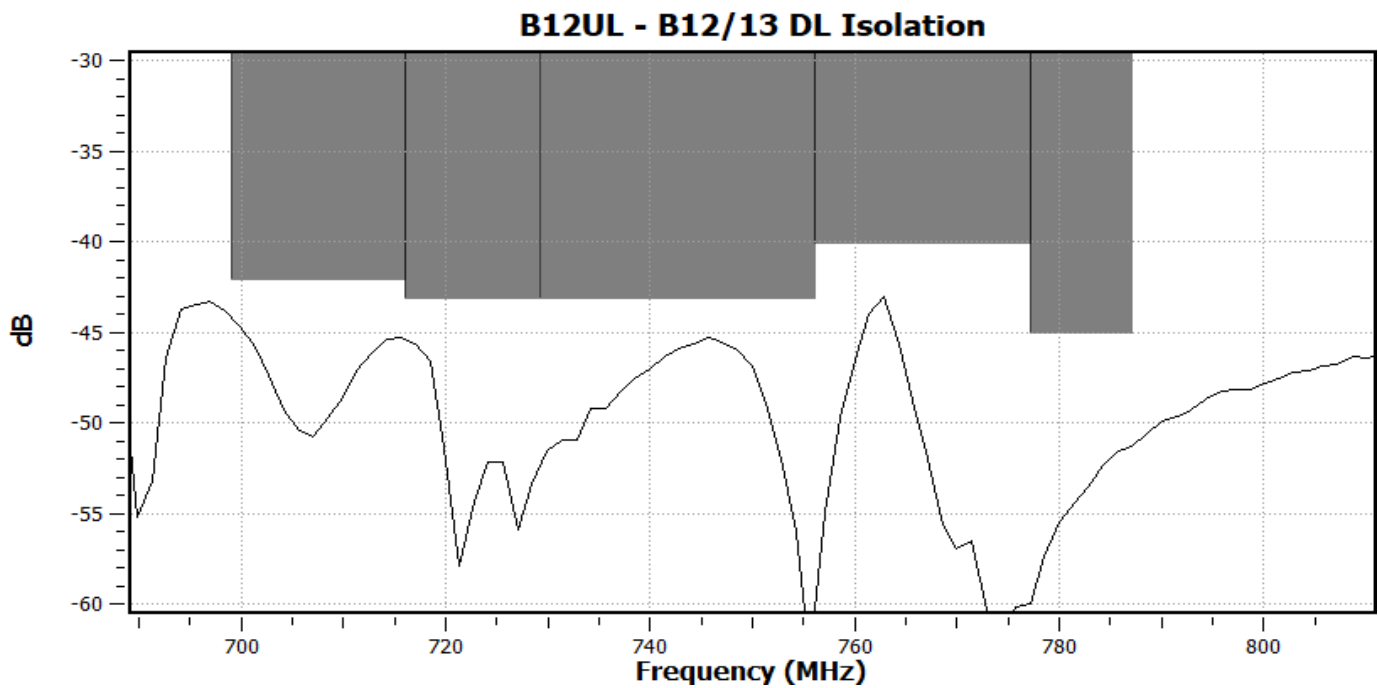
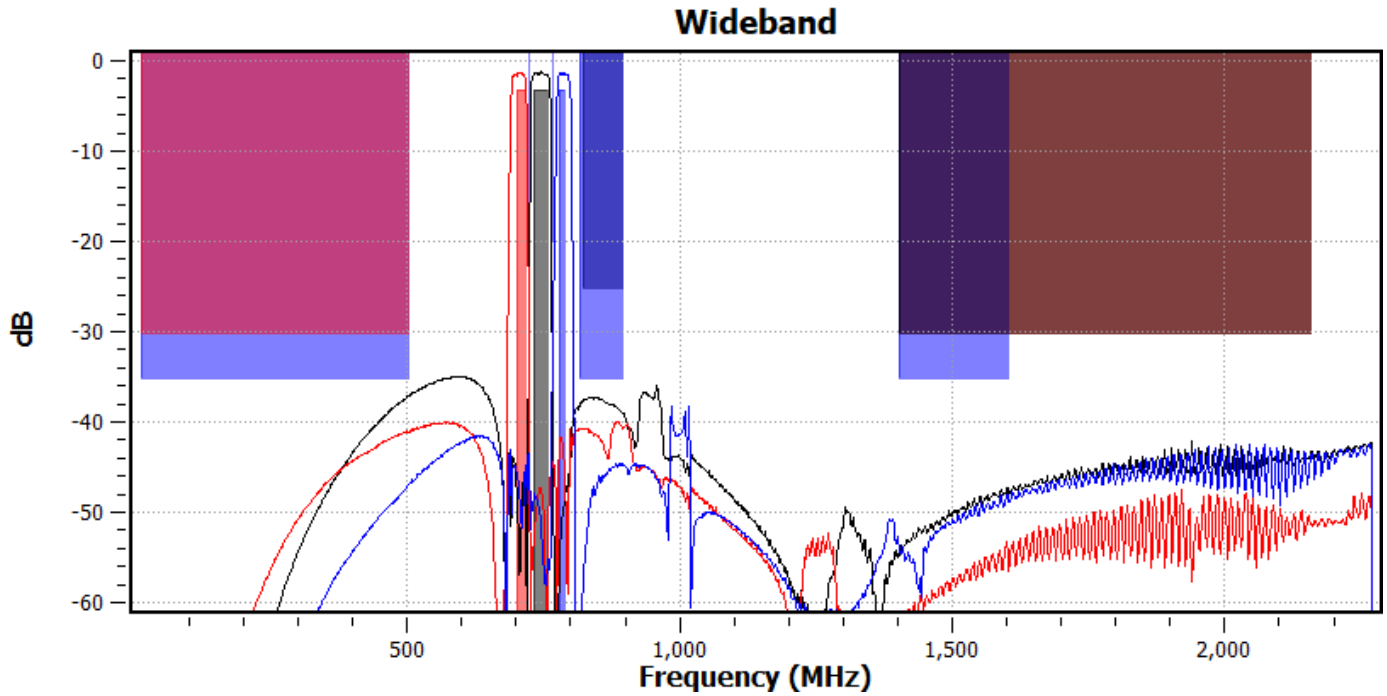

Performance Plots

Test conditions unless otherwise noted: Temp= +25°C

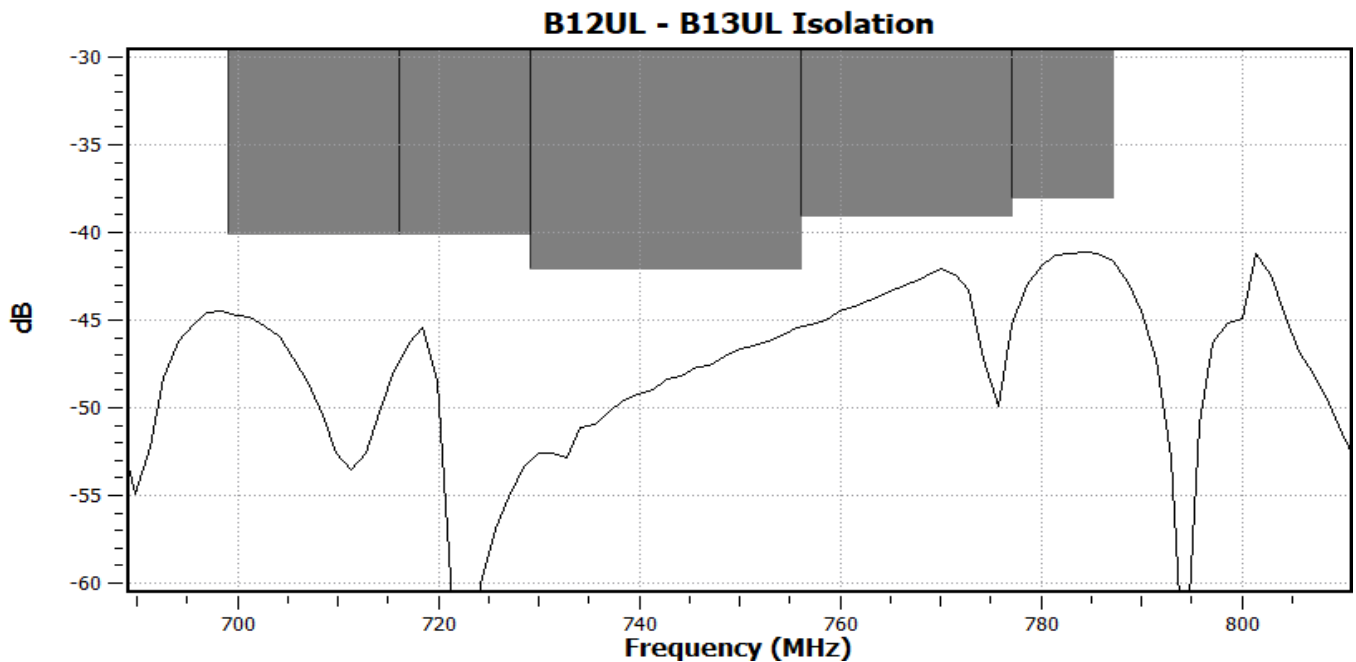
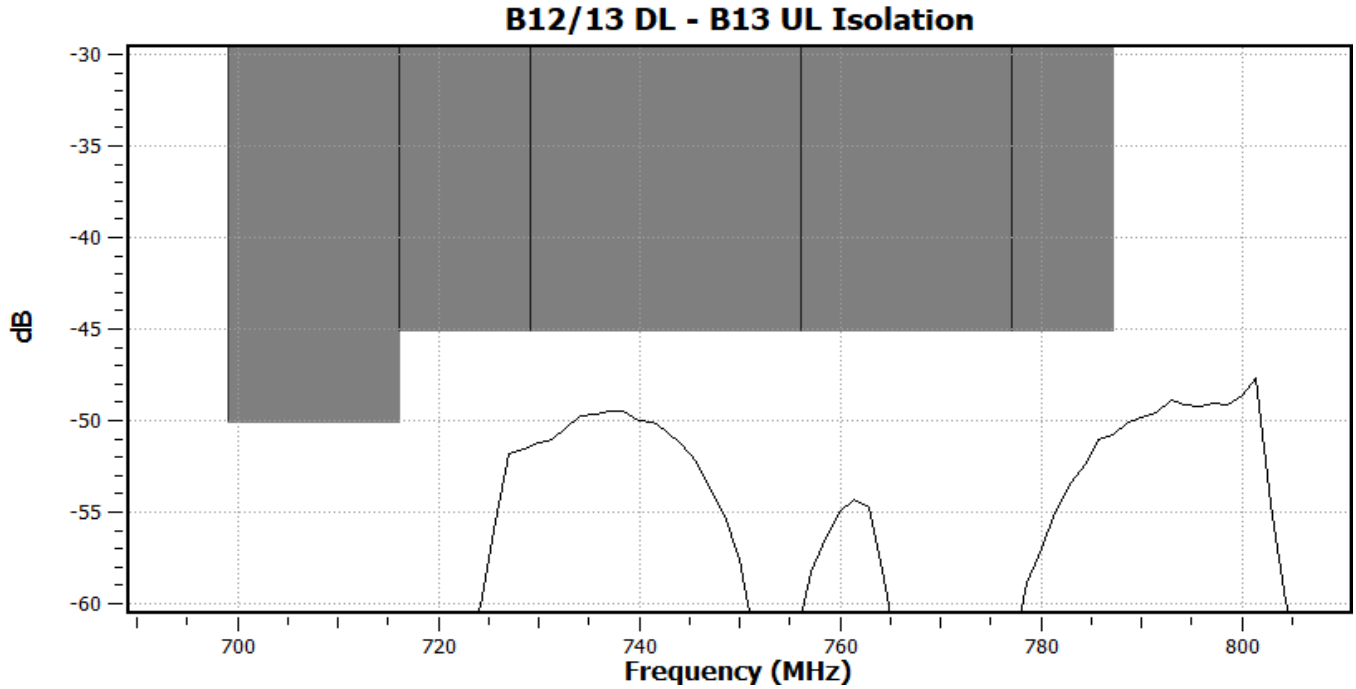

QPQ1214-PCB Evaluation Board

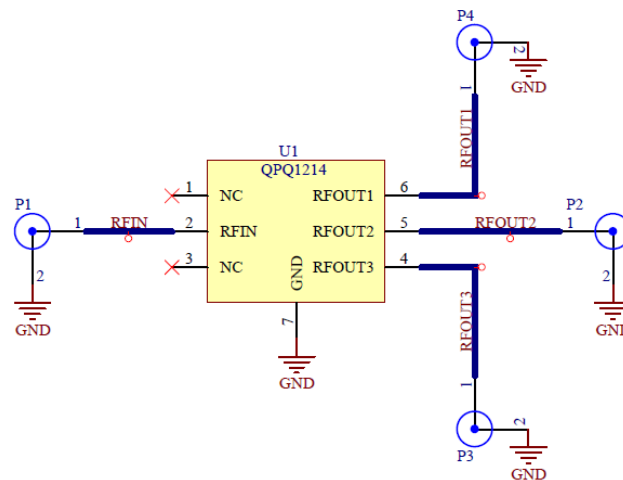
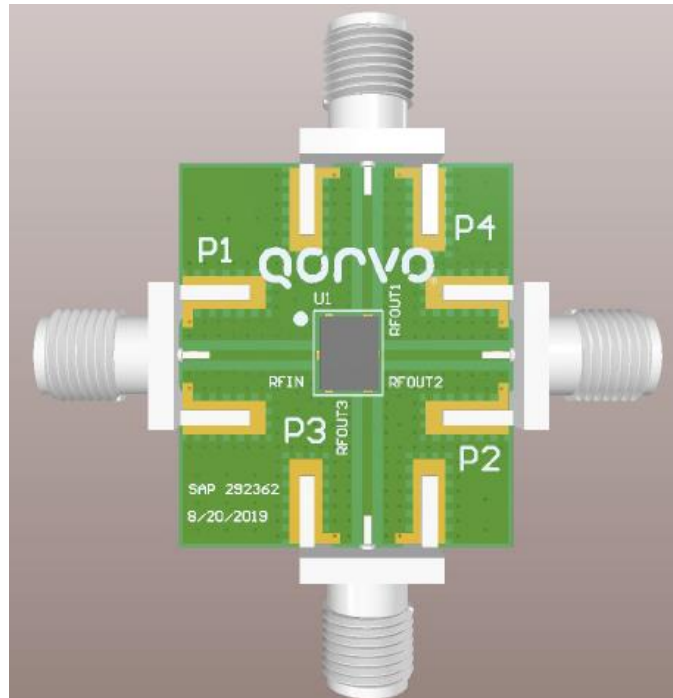

Note: Blocking capacitors are required on any ports where a DC voltage may be present.

Bill of material - QPQ1214EVB

Reference Des.	Value	Description	Manuf.	Part Number
U1	-	Band 12/13 Triplexer High Power	Qorvo	QPQ1214
PCB	-	Printed Circuit Board	Various	
J1, J2, J3, J4	-	SMA Edge Connector	Various	

Package Marking and Dimensions

Marking:

4-digit Part number: 1214

4-digit Trace code: YYYY

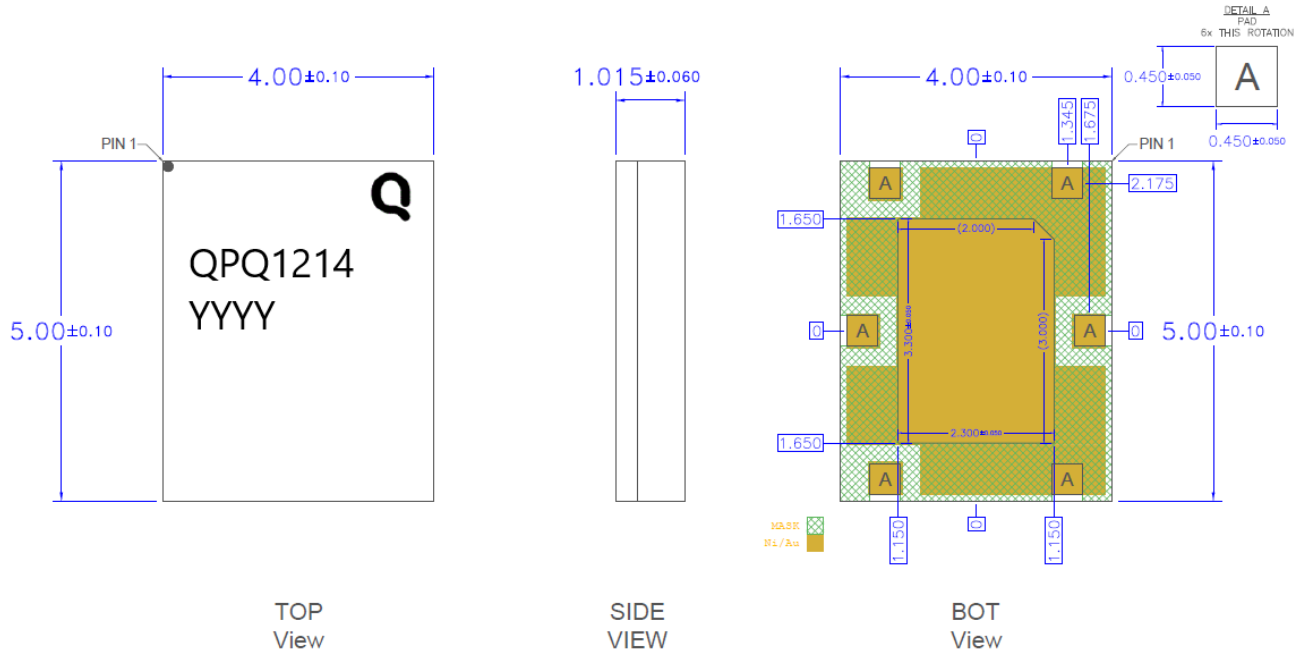

Notes:

1. All dimensions are in millimeters. Angles are in degrees.
2. Dimension and tolerance formats conform to ASME Y14.4M-1994.
3. The terminal #1 identifier and terminal numbering conform to JESD 95-1 SPP-012.

PCB Mounting Pattern

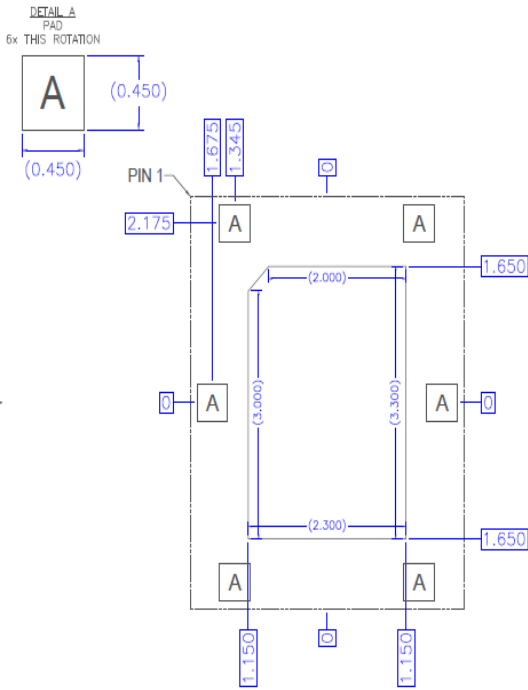

Recommended
Land Pattern

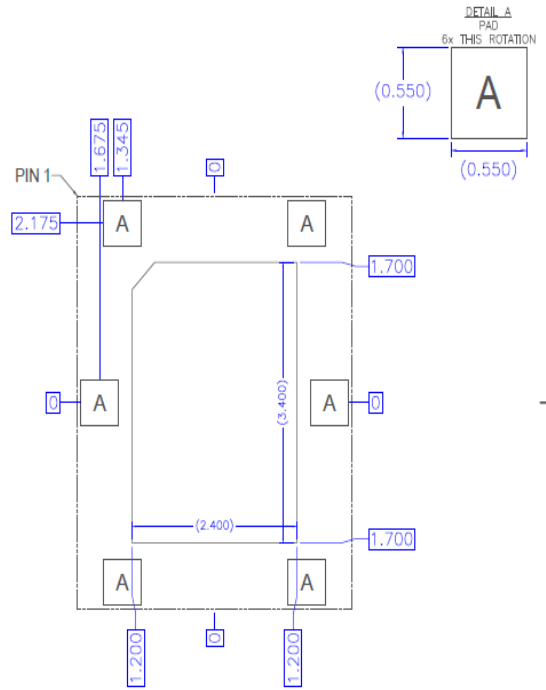

Recommended
Land Pattern Mask

Notes:

1. All dimensions are in millimeters.
2. This drawing specifies the mounting pattern used on the Qorvo evaluation board for this product. Some modification may be necessary to suit end user assembly materials and processes

Tape and Reel Information – Carrier and Cover Tape Dimensions

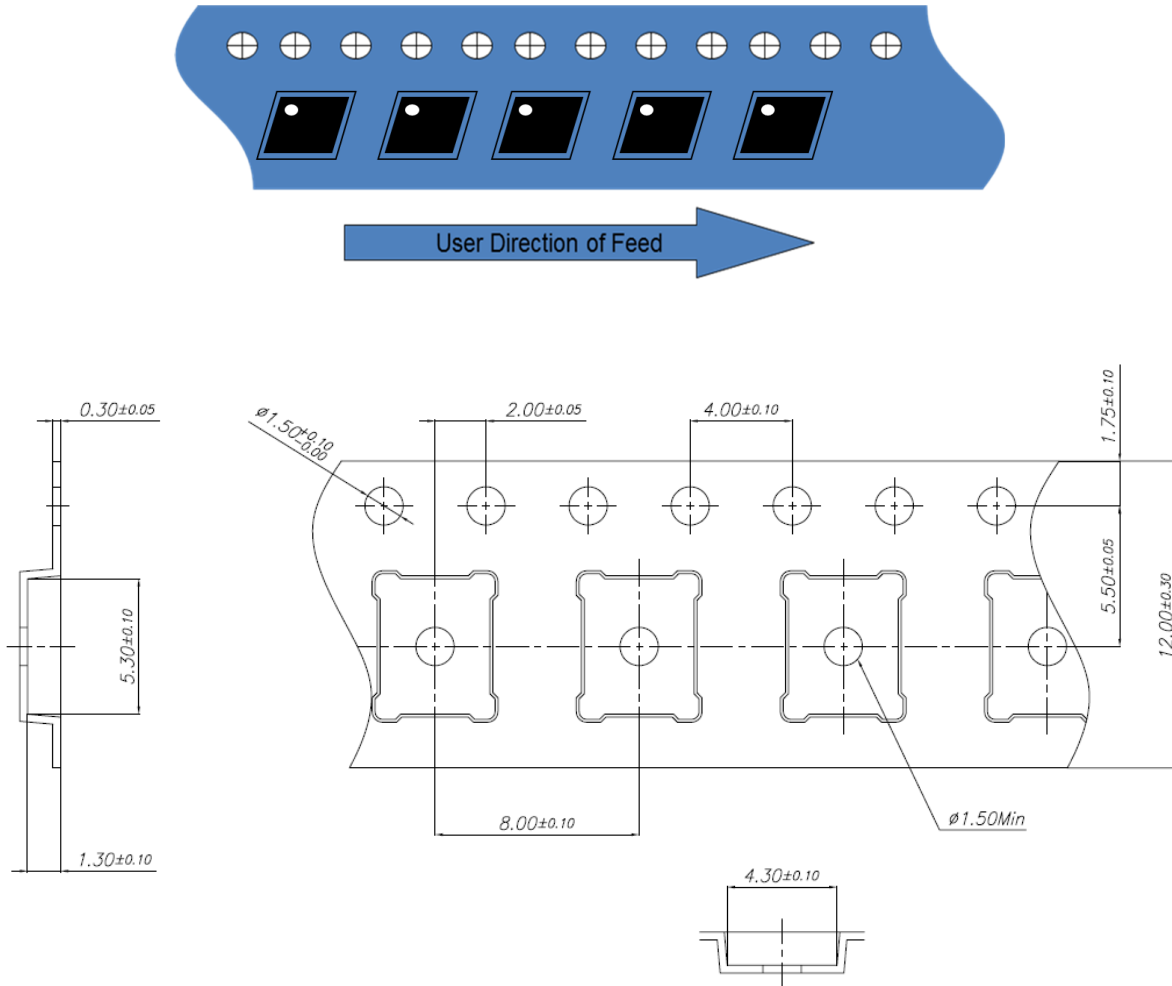

Feature	Measure	Symbol	Size (in)	Size (mm)
Cavity	Length	A0	0.169	4.30
	Width	B0	0.209	5.30
	Depth	K0	0.051	1.30
	Pitch	P1	0.315	8.00
Centerline Distance	Cavity to Perforation - Length Direction	P2	0.079	2.00
	Cavity to Perforation - Width Direction	F	0.217	5.50
Cover Tape	Width	C	0.362	9.20
Carrier Tape	Width	W	0.472	12.00

Tape and Reel Information – Reel Dimensions (13")

Standard T/R size = 2,500 pieces on a 13" reel.

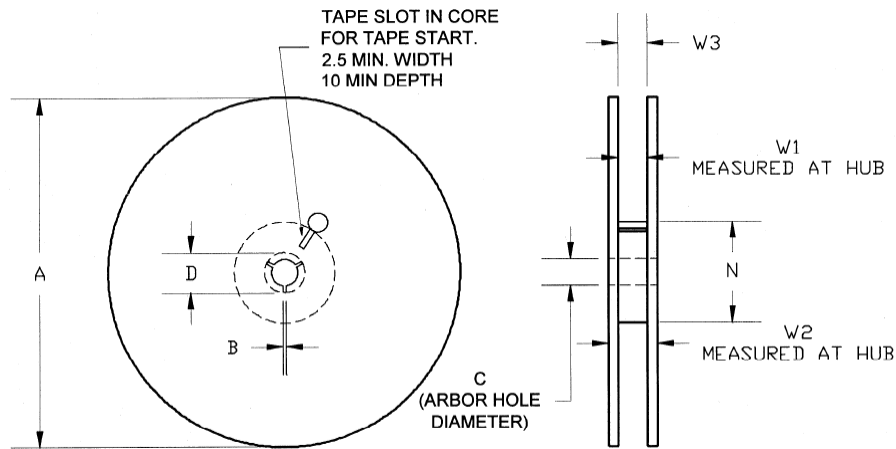

Feature	Measure	Symbol	Size (in)	Size (mm)
Flange	Diameter	A	12.992	330.0
	Thickness	W2	0.717	18.2
	Space Between Flange	W1	0.504	12.8
Hub	Outer Diameter	N	4.016	102.0
	Arbor Hole Diameter	C	0.512	13.0
	Key Slit Width	B	0.079	2.0
	Key Slit Diameter	D	0.787	20.0

Tape and Reel Information – Tape Length and Label Placement

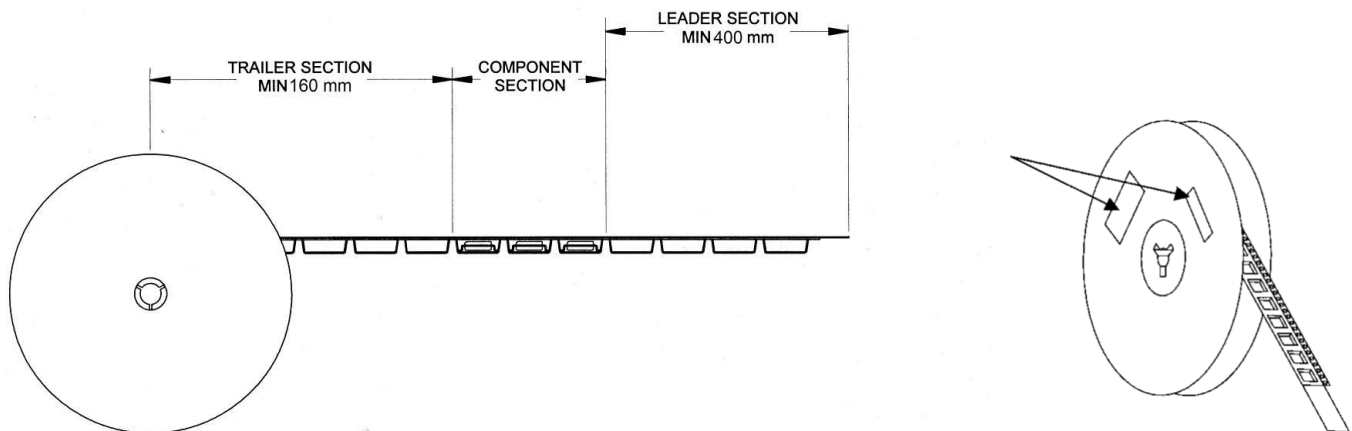

Notes:

1. Empty part cavities at the trailing and leading ends are sealed with cover tape. See EIA 481-1-A.
2. Labels are placed on the flange opposite the sprockets in the carrier tape.

Assembly Notes

1. Compatible with both Lead-free solder (260°C peak reflow temperature) and tin/lead (245°C peak reflow temp.) soldering processes.
2. Contact plating: Ni-Pd-Au.

Recommended Soldering Temperature Profile

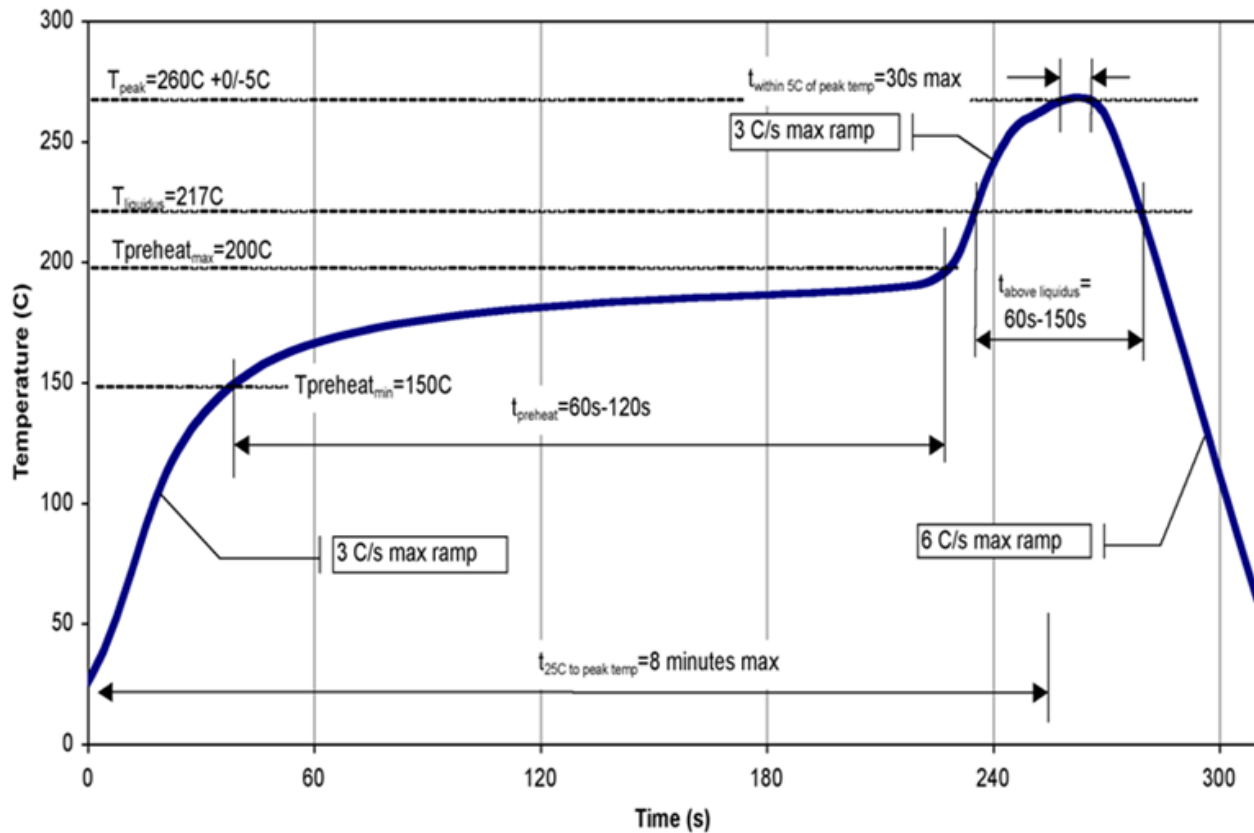

Handling Precautions

Parameter	Rating	Standard
ESD – Human Body Model (HBM)	Class 2	ESDA / JEDEC JS-001-2012
ESD – Charged Device Model (CDM)	Class C3	ESDA / JESD22-C101
MSL – Moisture Sensitivity Level	Level 3	IPC/JEDEC J-STD-020



Caution!
ESD-Sensitive Device

RoHS Compliance

This part is compliant with 2011/65/EU RoHS directive (Restrictions on the Use of Certain Hazardous Substances in Electrical and Electronic Equipment) as amended by Directive 2015/863/EU.

This product also has the following attributes:

- Lead Free
- Halogen Free (Chlorine, Bromine)
- Antimony Free
- TBBP-A (C₁₅H₁₂Br₄O₂) Free
- SVHC Free



Contact Information

For the latest specifications, additional product information, worldwide sales and distribution locations:

Web: www.qorvo.com

Tel: 1-844-890-8163

Email: customer.support@qorvo.com

Important Notice

The information contained herein is believed to be reliable; however, Qorvo makes no warranties regarding the information contained herein and assumes no responsibility or liability whatsoever for the use of the information contained herein. All information contained herein is subject to change without notice. Customers should obtain and verify the latest relevant information before placing orders for Qorvo products. The information contained herein or any use of such information does not grant, explicitly or implicitly, to any party any patent rights, licenses, or any other intellectual property rights, whether with regard to such information itself or anything described by such information. **THIS INFORMATION DOES NOT CONSTITUTE A WARRANTY WITH RESPECT TO THE PRODUCTS DESCRIBED HEREIN, AND QORVO HEREBY DISCLAIMS ANY AND ALL WARRANTIES WITH RESPECT TO SUCH PRODUCTS WHETHER EXPRESS OR IMPLIED BY LAW, COURSE OF DEALING, COURSE OF PERFORMANCE, USAGE OF TRADE OR OTHERWISE, INCLUDING THE IMPLIED WARRANTIES OF MERCHANTABILITY AND FITNESS FOR A PARTICULAR PURPOSE.**

Without limiting the generality of the foregoing, Qorvo products are not warranted or authorized for use as critical components in medical, life-saving, or life-sustaining applications, or other applications where a failure would reasonably be expected to cause severe personal injury or death.

Copyright 2020 © Qorvo, Inc. | Qorvo is a registered trademark of Qorvo, Inc.