

NI 9684

General Purpose Inverter Controller RIO Mezzanine Card

This document describes the features of the NI 9684 and contains mounting instructions and specifications.

Figure 1. NI 9684

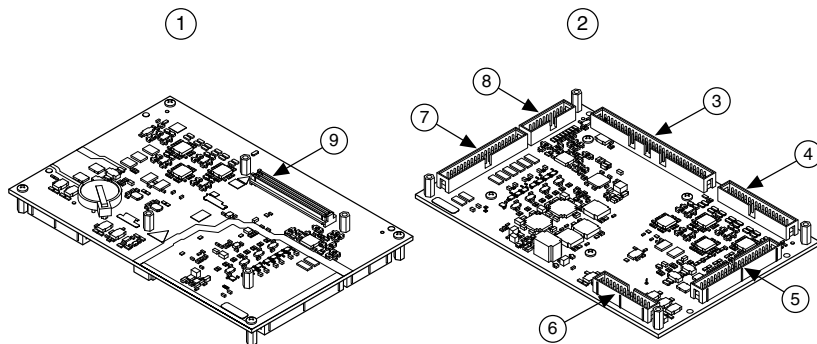

- | | |
|------------------------------------|------------------------------|
| 1. Primary Side | 6. Half-bridge DO |
| 2. Secondary Side | 7. Simultaneous AI |
| 3. LVTTTL DIO | 8. Scanned AI and AO |
| 4. Sourcing DI | 9. sbRIO Mezzanine Connector |
| 5. Sinking DO and Relay Control DO | |

Safety Guidelines



Caution Do not operate the NI 9684 in a manner not specified in this document. Product misuse can result in a hazard. You can compromise the safety protection built into the product if the product is damaged in any way. If the product is damaged, return it to NI for repair.



Caution NI makes no product safety, electromagnetic compatibility (EMC), or CE marking compliance claims for the NI 9684. The end-product supplier is responsible for conformity to any and all compliance requirements.



Caution The NI 9684 must be installed inside a suitable enclosure prior to use. Hazardous voltages may be present.



Caution Exercise caution when placing the NI 9684 inside an enclosure. Auxiliary cooling may be necessary to keep the device under the maximum ambient temperature rating for the NI 9684. Refer to the Specifications section for more information about the maximum ambient temperature rating.



Caution The NI 9684 is designed for low voltage signals. You must ensure that all signals connected to the NI 9684 are not hazardous. A hazardous voltage is a voltage greater than 42.4 Vpk or 60 VDC to earth ground.



Caution Do not connect the NI 9684 to signals or use for measurements within Measurement Categories II, III, or IV.



Caution Use the NI 9684 with only NI sbRIO-9605/9606/9607 devices. The NI 9684 is not electrically or mechanically compatible with other NI sbRIO devices.

Dimensions

The following figures show the NI 9684 dimensions. For detailed dimensional drawings and 3D models, visit ni.com/dimensions and search for the NI 9684.

Figure 2. Primary Side Dimensions in Millimeters (Inches)

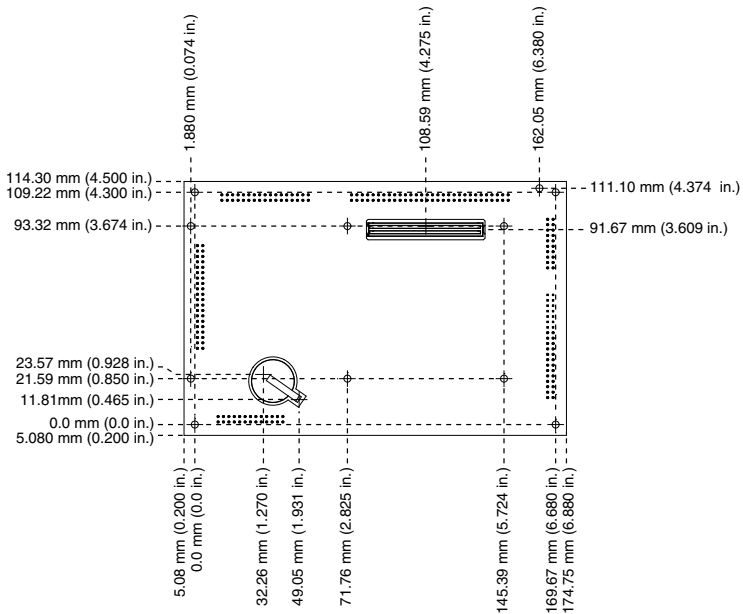

Figure 3. Secondary Side Dimensions in Millimeters (Inches)

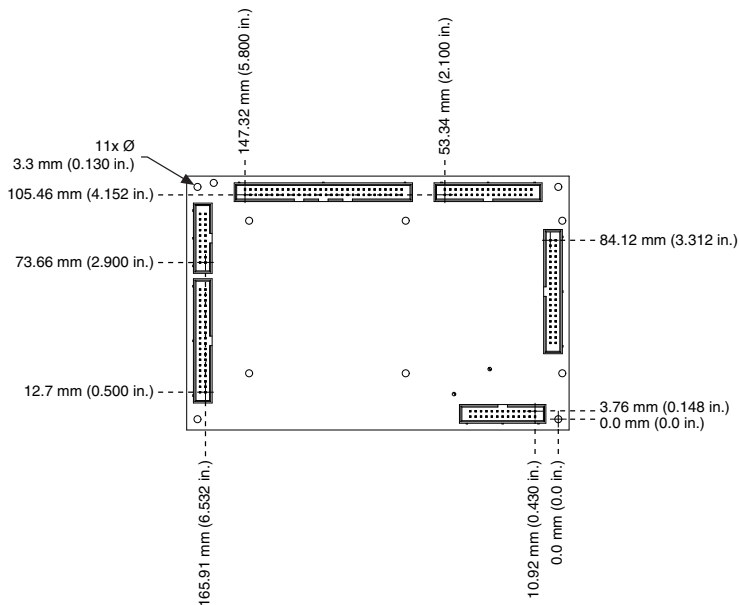
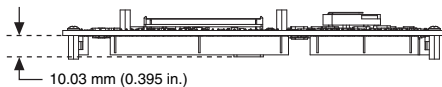

Figure 4. Maximum Height of Components in Millimeters (Inches)



Mounting the NI 9684

Mount the NI 9684 to a thermally conductive surface that is at least 3 mm thick.

What to Use

- NI 9684
- Mounting hardware, included with the NI 9684
 - Standoff, M3 x 9.65, M-F, 4.5 HEX, SS, NYL (x4)
 - Standoff, M3 x 11.12, M-F, 4.5 HEX, SS, NYL (x4)
 - Standoff, M3 x 29.81, M-F, 4.5 HEX, SS, NYL (x4)
 - Standoff, M3 x 43.36, M-F, 4.5 HEX, SS, NYL (x4)
 - Screw, M3 x 5, Panhead, PHIL, SS, NYL (x12)



Note Eight M3 nuts are also included with the NI 9684 mounting hardware. The M3 nuts are provided to secure the heat spreader/NI 9684/sbRIO/interface

board assembly for temporary mounting configurations where holes are not tapped into the mounting surface. To prevent possible damage to the device, use caution when installing the M3 nuts.

- NI sbRIO-9607
- sbRIO Thermal Kit for the NI sbRIO-9607
 - Heat spreader
 - Gap pad
 - Standoff, M3 x 16, M-F, 4.5 HEX, SS, NYL (x4)
- #1 Phillips screwdriver
- 4.5 mm hex nut driver
- Automatic screwdriver
- Thermal interface material

What to Do

Complete the following steps to mount the NI 9684.



Tip Tighten all standoffs and screws to a maximum torque of $0.56 \text{ N} \cdot \text{m}$ ($5 \text{ lb} \cdot \text{in.}$).

1. Prepare the mounting surface by tapping holes according to the [Surface Mounting Dimensions](#).
2. Install the heat spreader to the mounting surface.
 - a) Apply a thermal interface material, such as grease, to the flat side of the heat spreader.
 - b) Align the heat spreader with the tapped holes for the NI sbRIO-9607.
 - c) Fasten the M3 x 16, M-F standoffs through the heat spreader to the tapped holes for the NI sbRIO-9607.

Figure 5. Mounting the Heat Spreader

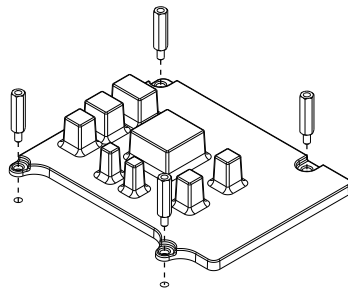

3. Install the NI sbRIO-9607.
 - a) Apply the gap pad to the NI sbRIO-9607. Refer to the Thermal Kit Installation Instructions for information about gap pad placement.
 - b) Align the NI sbRIO-9607 with the heat spreader.
 - c) Fasten the M3 x 9.65, M-F standoffs through the NI sbRIO-9607 to the M3 x 16, M-F standoffs.

Figure 6. Installing the NI sbRIO-9607

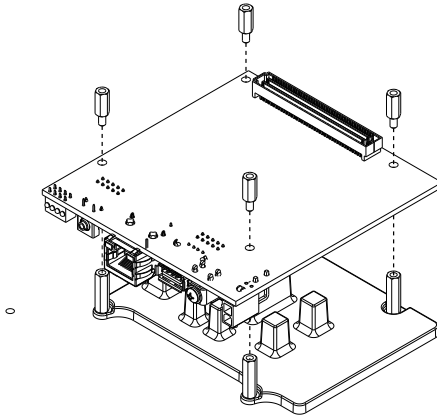

Caution The gap pad is a viscoelastic material and compressing it too quickly places a large amount of stress on board components. If you must use an automatic screwdriver, fasten these screws at a rate less than 4.23 mm/s (10 in./min.) to prevent damage during assembly.

4. Install the NI 9684.
 - a) Install the M3 x 29.81, M-F standoffs to the tapped holes for the NI 9684.
 - b) Align the NI 9684 with the M3 x 29.81, M-F standoffs and the NI sbRIO-9607.
 - c) Seat the mezzanine card connectors on the NI 9684 and the NI sbRIO-9607 to connect the boards.
 - d) Fasten the M3 x 11.12, M-F standoffs through the NI 9684 to the M3 x 29.81, M-F standoffs.
 - e) Insert four M3 x 5 panhead screws through the NI 9684 to the installed M3 x 9.65, M-F standoffs.

Figure 7. Mating the NI 9684 to the NI sbRIO-9607

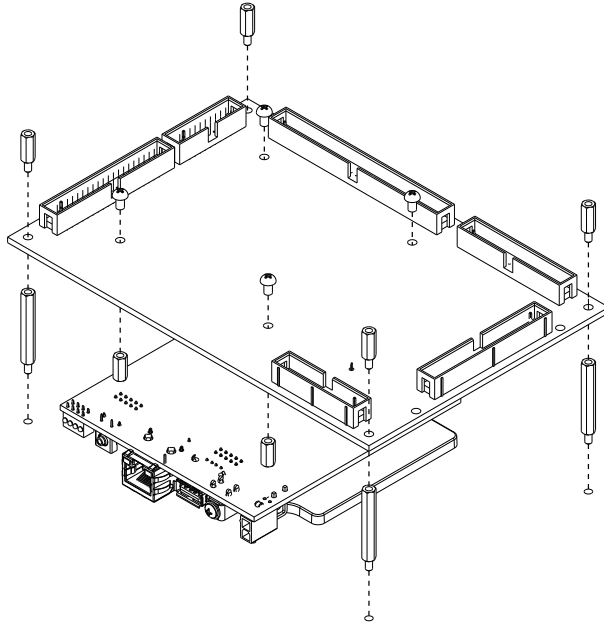

5. Install the interface board for your application.
 - a) Install the M3 x 43.36, M-F standoffs in the tapped holes for the interface board.
 - b) Align the interface board with the M3 x 43.36, M-F standoffs and the NI 9684.
 - c) Seat the connectors on the interface board and the NI 9684 to connect the boards.
 - d) Insert eight M3 x 5 panhead screws through the interface board to the M3 x 43.36, M-F standoffs and the M3 x 11.12, M-F standoffs.

Figure 8. Mating the Interface Board to the NI 9684

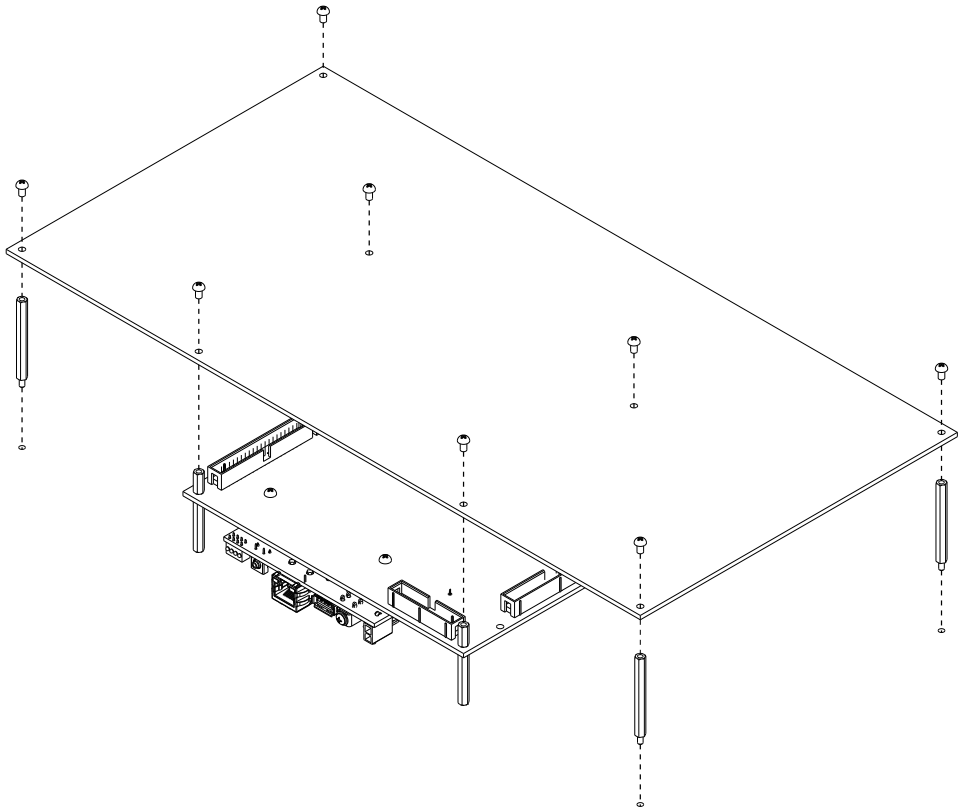

Surface Mounting Dimensions

Figure 9. Surface Mounting Dimensions in Millimeters (Inches)

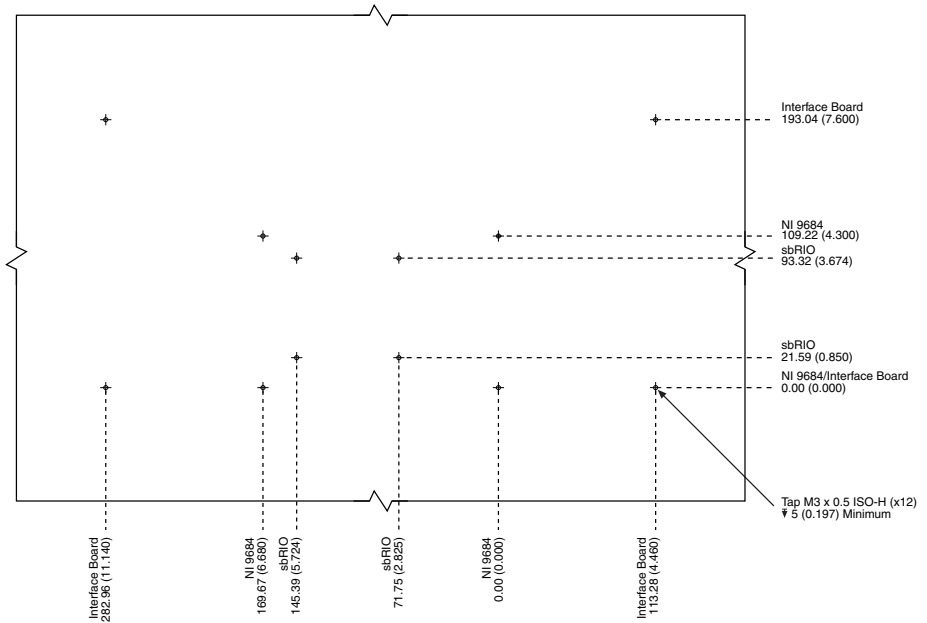

Installing Software on the Host Computer

Before using the NI 9684, you must install the following application software and device drivers on the host computer.

1. LabVIEW 2016 or later
2. LabVIEW Real-Time Module 2016 or later
3. LabVIEW FPGA Module 2016 or later
4. NI CompactRIO Device Driver 16.0 or later
5. NI CompactRIO Module Support 16.2.1 or later

Visit ni.com/info and enter the Info Code `softwareversion` for minimum software support information.

Pinout

Figure 10. NI 9684 Pinout

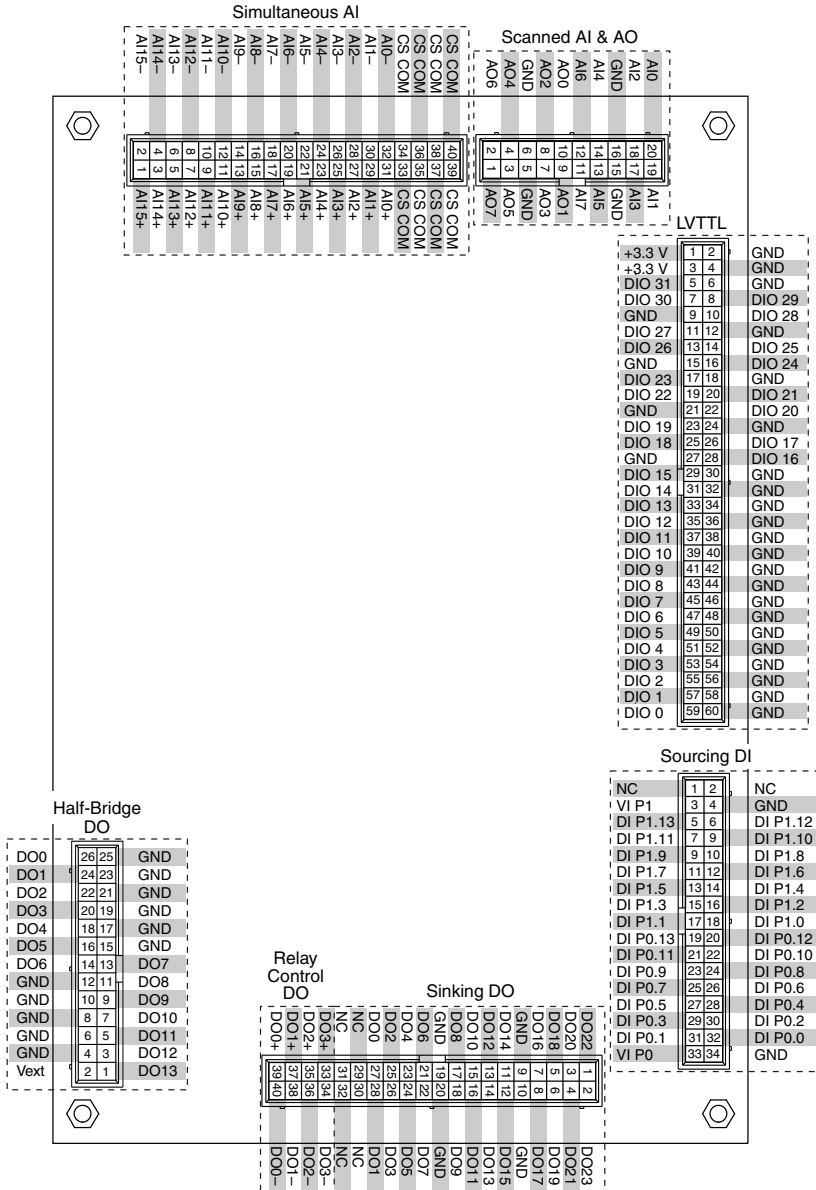

Connectors

The following table lists the NI 9684 connectors and recommended mating connectors. Refer to the manufacturer for information about using and matching these connectors.

Table 1. NI 9684 Connectors

Connector	Description	Recommended Mating Connector
Simultaneous AI	40-position header	On-Shore Technology, Inc. (SH2-40G-PT)
Scanned AI, AO	20-position header	On-Shore Technology, Inc. (SH2-20G-PT)
Sourcing DI	34-position header	On-Shore Technology, Inc. (SH2-34G-PT)
Sinking DO, Relay Control DO	40-position header	On-Shore Technology, Inc. (SH2-40G-PT)
Half-Bridge DO	26-position header	On-Shore Technology, Inc. (SH2-26G-PT)
LVTTTL DIO	60-position header	On-Shore Technology, Inc. (SH2-60G-PT)

Simultaneous Analog Input

The NI 9684 provides connections for 16 pseudo-differential analog input channels.

Each channel has an AI+ and AI- pin to which you can connect a voltage signal. AI- is internally connected to the isolated ground reference through a high value resistor.

Circuitry

The incoming analog signal on each channel is buffered and conditioned by the differential amplifier and then sampled by a 16-bit ADC. The NI 9684 analog channels share a common ground that is isolated from other parts of the board. The NI 9684 protects each channel from overvoltages.

Each channel has an independent track-and-hold amplifier and ADC that allow you to sample and convert all 16 channel simultaneously.

Connecting Differential and Single-Ended Voltage Signals to the Simultaneous AI

You can connect differential or single-ended signal sources to the simultaneous AI on the NI 9684.

Figure 11. Connecting a Differential Voltage Signal to a Simultaneous AI Channel

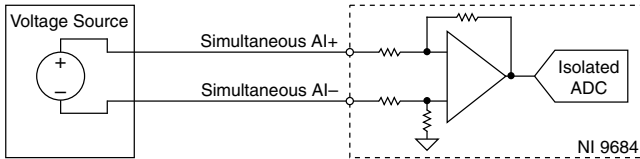
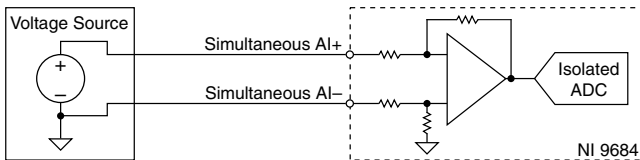

Figure 12. Connecting a Single-Ended Voltage Signal to a Simultaneous AI Channel



Connecting Current Sensors to the Simultaneous AI

You can connect current sensors to the NI 9684 using a termination resistor to convert the current measurement to a single-ended voltage measurement. Connect the current sensor output to AI+ and the external power supply COM to the current sensor common pin (CS COM) on the NI 9684.

Figure 13. Connecting a Current Sensor

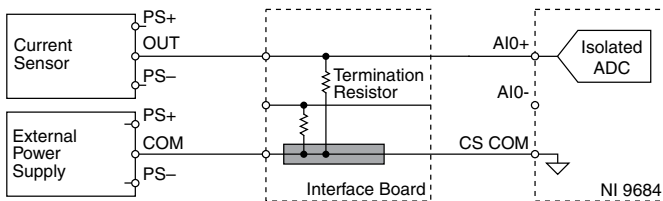

To avoid the affect of common mode impedance on the measurement, connect one end of all the termination resistors to a single, small plane. Then have a single connection from the plane to the CS COM pin of the NI 9684.

Termination Resistor Values

The NI 9684 simultaneous analog inputs have ± 10 V and ± 5 V input ranges that can accommodate termination resistor values in a certain range, based on the sensor peak current.

Select the highest possible termination resistor to maximize the dynamic range of the analog input.

Use the following equation to determine the maximum value for the terminal resistor based on the sensor peak current.

Figure 14. Termination Resistor Equation

$$R_{\text{maximum}} = \frac{5 \text{ V}}{I_{\text{peak}_{\text{maximum}}}}$$

For a current sensor with a peak output current of 70 mA, the maximum termination resistor that can be used with the NI 9684 is as follows:

Figure 15. Termination Resistor Example

$$R_{\text{maximum}} = \frac{5 \text{ V}}{0.07 \text{ A}} = 71 \Omega$$



Note Using the $\pm 5 \text{ V}$ input range can reduce the power dissipation on the termination resistor by 50% when compared to the power dissipation of the $\pm 10 \text{ V}$ input range.

Scanned Analog Input (Monitoring)

The NI 9684 provides connections for eight single-ended scanned analog input channels.

Each channel has an AI pin to which you can connect a voltage signal. Scanned analog input and analog output channels share four GND pins on the dedicated 20-position connector.

Connecting Single-Ended Voltage Signals to the Scanned AI

You can connect single-ended signal sources to the scanned AI on the NI 9684.

Figure 16. Connecting Single-Ended Voltage Signals to the Scanned Analog Inputs

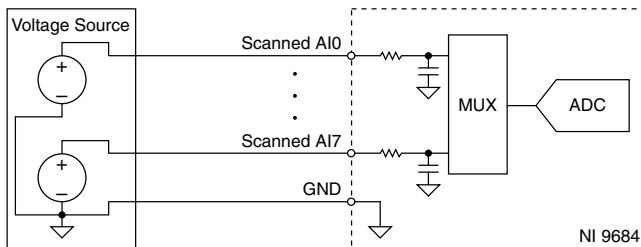

Scanned AI Accuracy and Bandwidth

Use signal sources with an output impedance of less than 2 k Ω to ensure specified performance. Large source impedances add to the input resistor inside the NI 9684, which

results in increased settling time and decreases the accuracy of the measurement. Increased input impedance also results in a decrease of the -3 dB bandwidth.

Analog Output (Set-Point)

The NI 9684 provides connections for eight single-ended analog output channels.

Each channel has an AO pin to which you can connect a load. Analog output and scanned analog input channels share four GND pins on the dedicated 20-position connector.

Connecting a Load to the AO

You can connect a load to the AO on the NI 9684.

Figure 17. Connecting a Load to the Analog Outputs

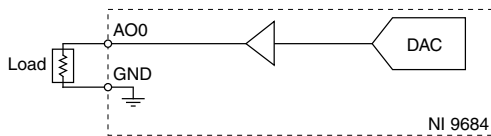

Half-Bridge Digital Output

The NI 9684 provides connections for 14 half-bridge digital output channels.

Each channel has a half-bridge DO pin to which you can connect a digital input device. An external power supply referenced to ground of the board must be connected to Vext.

The NI 9684 half-bridge digital outputs are push-pull, meaning the NI 9684 can sink or source current. When the channel is ON, the half-bridge DO pin is driven to the external power supply minus a voltage drop due to the sourced current. When the channel is turned OFF, the half-bridge DO pin is driven to ground plus a voltage drop due to the sinked current.

Connecting Digital Devices to the Half-Bridge DO

You can connect digital devices to the half-bridge DO.

Figure 18. Connecting a Digital Device to a Half-Bridge DO Channel

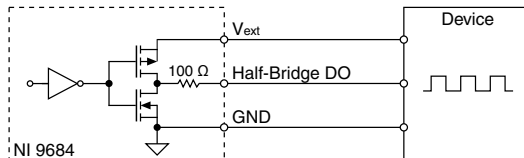

Note Make sure the devices you connect to the NI 9684 are compatible with the half-bridge digital output specifications. Use connections that match the output impedance of the NI 9684 half-bridge outputs.

Sinking Digital Output

The NI 9684 provides connections for 24 sinking digital output channels.

Each channel has a sinking DO pin to which you can connect a digital input device. Sinking DO pins have dedicated current return pins, GND, which are referenced to the ground of the board.

The NI 9684 has current sinking digital outputs, meaning that the output pin is driven to ground (GND) when the channel is ON.

Connecting Digital Devices to the Sinking DO

You can connect digital devices to the sinking DO.

Figure 19. Connecting a Digital Device to a Sinking DO Channel

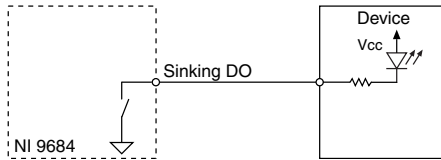

Note Make sure the devices you connect to the NI 9684 are compatible with the output specifications.

Increasing Current Drive

Each channel of the NI 9684 has a continuous output current of 20 mA. If you want to increase the output current to a device, you can connect any number of channels together in parallel.

For example, if you want to drive 80 mA of current, connect DO<0..3> in parallel, as shown in the following figure. You must turn all parallel channels on and off simultaneously so that the current on any single channel cannot exceed the 20 mA rating.

Figure 20. Increasing the Current to a Device Connected to the NI 9684

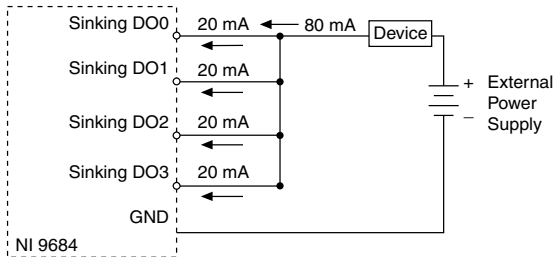

Relay Control Digital Output

The NI 9684 provides connections for four relay control digital output channels.

Each channel has a relay control DO+ and a current return pin, relay control DO-.

The NI 9684 has current sinking outputs, meaning the relay control DO+ is driven to relay control DO- when the channel is ON.

Connecting Industrial Devices to the Relay Control DO

You can connect industrial devices such as solenoids, actuators, relays, and lamps to the relay control DO.

Figure 21. Connecting an Industrial Device to a Relay Control DO Channel

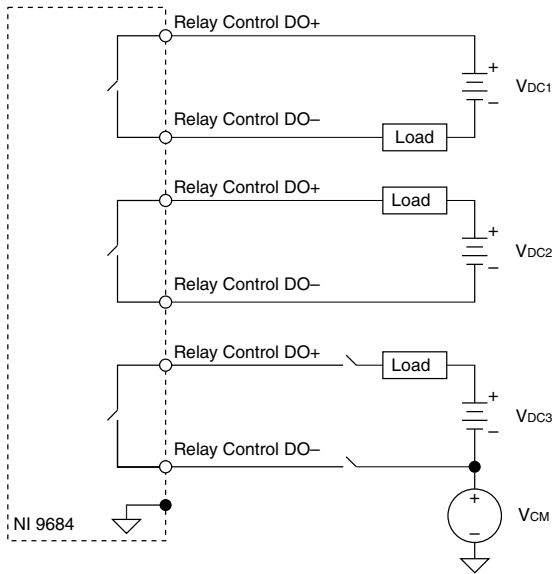

Note Ensure that all the relay control DO+/- pins are held within the safety voltage levels. A maximum common mode voltage of 30 VDC is allowed at a relay control DO+/- pin with respect to the GND of the NI 9684.



Note NI recommends using the appropriate cabling for the current return pins based on the amount of current returned per each relay control DO- output.



Note Make sure the devices you connect to the NI 9684 are compatible with the output specifications

Protecting the Digital Outputs from Flyback Voltages

If the channel is switching an inductive or energy-storing device such as a solenoid, motor, or relay, and the device does not have flyback protection, install an external flyback diode.

Figure 22. Connecting a Flyback Diode

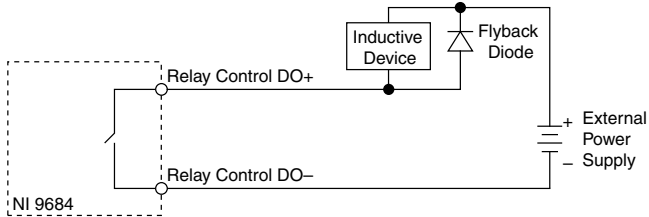

Selecting a Wire Gauge for Relay Control DO

The relay control digital output is capable of sinking 8 A of inrush current for a period of 300 ms on a 60 second cycle and 500 mA of continuous current. Each channel is functionally isolated from the other channels and the rest of the board, meaning that each relay control digital output has a dedicated current return pin.

When using cables, make sure the current rating of the cable is able to handle the expected current for your application. For example, a typical 28 AWG flat ribbon cable is rated at 225 mA of continuous current per wire. In order to use the relay control digital outputs at their maximum current capability, cables within category 24 AWG or lower should be used.

Sourcing Digital Input

The NI 9684 provides connections for 28 simultaneously sampled digital input channels separated in ports P0 and P1. Ports P0 and P1 are independently powered using separate power supply pins, VI P0 and VI P1. This allows you to connect the DI to multivoltage systems.

Each channel has a DI pin to which you can connect a digital input signal. The supply pins, VI P0 and VI P1, are referenced to the ground of the board. The DI operates in the low range or high range based on the VI P0 or VI P1 voltage.

The NI 9684 has sourcing inputs, meaning the DI sources current from the VI P0 or VI P1 to the sinking output device. The NI 9684 internally limits current signals connected to DI. The channel registers ON when the sinking-output is in the ON range. The channel registers as OFF when the sinking-output is in the OFF range. If no device is connected to the sourcing DI, the channel registers as OFF.

Connecting Digital Devices to the Sourcing DI

You can only connect 3-wire sinking-output devices to the NI 9684.

Figure 23. Connecting a Digital Device to a Sourcing DI Channel

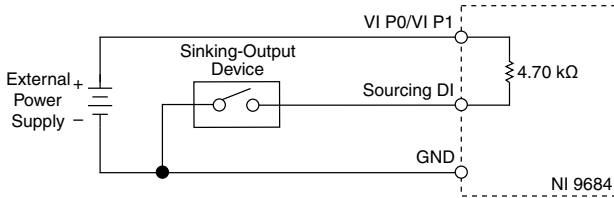

Note NI recommends that you leave sourcing DI channels that are not used in your application unconnected to lower power dissipation through the onboard pull-up resistor

LVTTL Digital Input/Output

The NI 9684 provides connections for 32 LVTTL digital input/output channels.

The NI 9684 LVTTL DIO channels connect directly to the FPGA DIO on the NI sbRIO-9607 and are unbuffered and unprotected.



Caution Operating the LVTTL DIO outside the rated specifications may result in permanent damage to the FPGA on NI sbRIO-9607.

If overshoot and undershoot aberrations and signal integrity are concerns for your application, use a single load per line that does not exceed 25 pF. For edge sensitive signals, use channels DIO0 through DIO15 for better signal integrity and crosstalk performance since these channels have an individual GND pin.

The LVTTL DIO channels on the NI 9684 are routed with a 55 Ω characteristic trace impedance. Route all external circuitry with a similar impedance to ensure the best signal quality.

Connecting Digital Devices to the LVTTL DIO

You can connect digital devices to the LVTTL DIO.

Figure 24. Connecting to the LVTTL DIO Channels

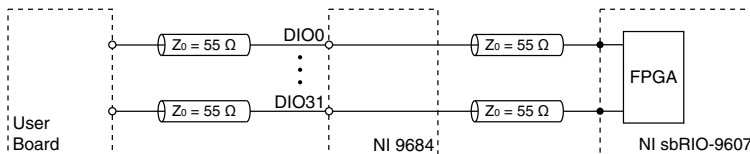

Perform signal integrity measurements to test the effect of signal routing and cable type on your application. To meet defined power-up states for outputs, use a pull-up or pull-down resistor on the line.

System Diagrams

The following figure shows a diagram for interfacing digital signals with the NI 9684.

Figure 25. Interfacing Digital Signals with the NI 9684

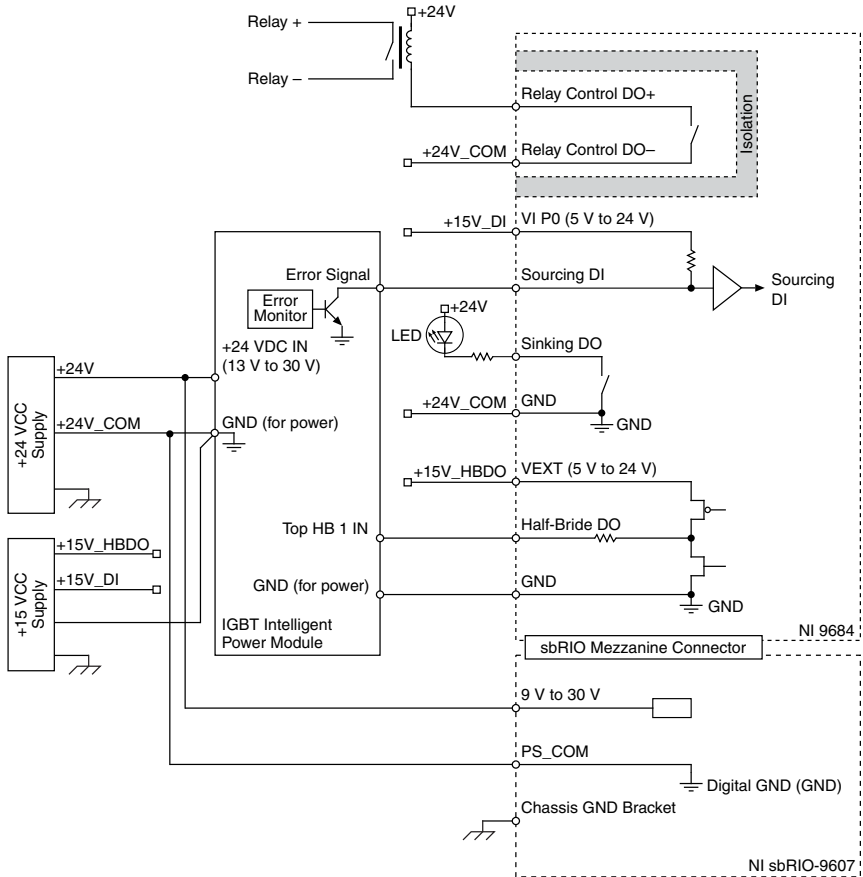

The following figure shows a diagram for interfacing analog signals with the NI 9684.

Figure 26. Interfacing Analog Signals with the NI 9684

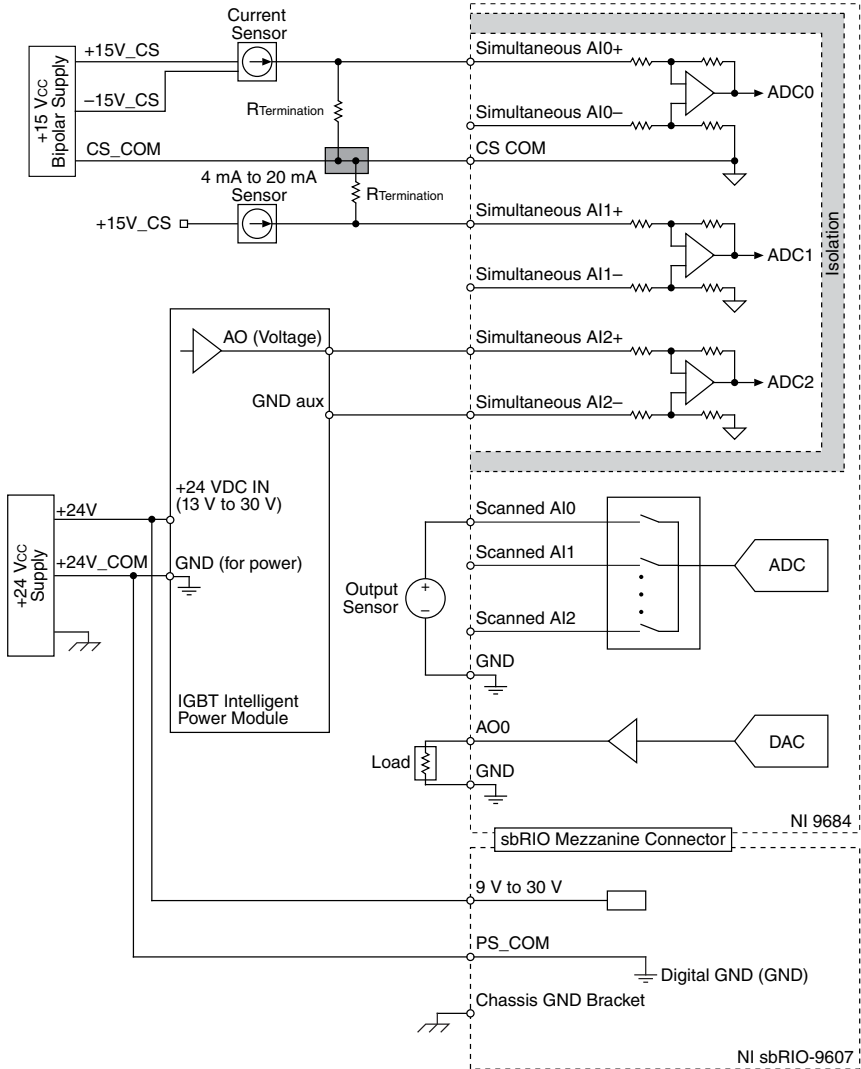

System Grounding Recommendations

NI recommends making the following connections to ground your system.

+24 VDC Power Supply Connections (Main Controller Power)

- Connect +24 V power to +24 VDC IN on the Semikron SKiiP3 26-pin connector
- Connect +24 V power to input power supply of the NI sbRIO-9607
- Connect +24 V GND/COM to GND input on the Semikron SKiiP3 26-pin connector
- Connect +24 V GND/COM to GND (Digital GND) input power supply of the NI sbRIO-9607
- Connect +24 V Earth (chassis) ground to system Earth (chassis) ground

+15 VDC Power Supply Connections (Gate Driver Control Signal Power)

- Connect +15 V power to Vext input on the NI 9684
- Connect +15 V GND/COM to GND input on the Semikron SKiiP3 26-pin connector
- Connect +15 V Earth (chassis) ground to system Earth (chassis) ground

±15 VDC Sensor Power Supply Connections (Sensor/Transducer Power)

- Connect ±15 V power to system sensors/transducers
- Connect ±15 V GND/COM to CS_COM input on the NI 9684



Note Do not connect ±15 V sensor GND/COM to any other system ground other than CS_COM.



Note Do not use the ±15 V sensor power supply as the gate driver control signal power supply.

Additional Grounding Connectivity

- Connect Semikron SKiiP3 heat sink to Earth (chassis) ground
- Connect NI sbRIO-9607 chassis ground metal terminal to Earth (chassis) ground
- Connect the shield of the cable interfacing the Semikron SKiiP3 to Earth (chassis) ground on your custom interface board

Specifications

The following specifications are typical for the full operating temperature range unless otherwise noted. Refer to the Environmental section for more information on operating temperatures.

Simultaneous Analog Input

Number of channels	16
ADC resolution	16 bits
Input range	
Typical	±5.2 V, ±10.4 V
Minimum	±5.1 V, ±10.2 V

Common-mode range	±10 V
Sample rate (per channel)	180 kS/s maximum

Table 2. Accuracy

Measurement Conditions	Nominal Range (V)	Measurement Conditions ¹	Percent of Reading (Gain Error)	Percent of Range ² (Offset Error) ³
Calibrated	±5 V	Maximum (-40 °C to 85 °C)	0.54%	0.200%
		Typical (23 °C ±5 °C)	0.13%	0.006%
	±10 V	Maximum (-40 °C to 85 °C)	0.54%	0.100%
		Typical (23 °C ±5 °C)	0.13%	0.003%
Uncalibrated ⁴	±5 V	Maximum (-40 °C to 85 °C)	1.08%	0.330%
		Typical (23 °C ±5 °C)	0.48%	0.030%
	±10 V	Maximum (-40 °C to 85 °C)	1.08%	0.165%
		Typical (23 °C ±5 °C)	0.48%	0.015%

Figure 27. Absolute Accuracy Equation

$$\text{Absolute Accuracy} = \text{Reading} \times \text{Gain Error} + \text{Range} \times \text{Offset Error} + \text{Noise}$$

Stability

Gain drift	26 ppm/°C
Offset drift	25 μV/°C
Noise	260 μVrms
-3 dB bandwidth	176 kHz

¹ Local ambient temperature. Refer to the Environmental section for more information about operating temperatures.

² Range equals 5.2 V for ±5 V or 10.4 V for ±10 V.

³ Offset error includes the effect of INL.

⁴ Uncalibrated accuracy refers to the accuracy achieved when acquiring data in raw or unscaled modes and in which calibration constants that are stored in the module are not applied to the data.

CMRR ($f_{in} = 60$ Hz)	51 dB minimum
Crosstalk ($f_{in} = 10$ kHz)	-69 dB
Input impedance	
Differential	250 k Ω
Single-ended	125 k Ω
Overvoltage protection	± 30 V maximum

Scanned Analog Input (Monitoring)

Number of channels	8
ADC resolution	12 bits
Input range	
Typical	0 V to 5 V
Minimum	12 mV to 4.97 V
Sample rate (per channel)	1 kS/s maximum

Table 3. Accuracy⁵

Measurement Conditions ⁶	Percent of Reading (Gain Error)	Percent of Range ⁷ (Offset Error) ⁸
Maximum (-40 °C to 85 °C)	0.30%	0.23%
Typical (23 °C ± 5 °C)	0.03%	0.02%

Figure 28. Absolute Accuracy Equation

$$\text{Absolute Accuracy} = \text{Reading} \times \text{Gain Error} + \text{Range} \times \text{Offset Error} + \text{Noise}$$

Stability

Gain drift	5 ppm/°C
Offset drift	22 μ V/°C
Noise	0.5 mVrms
-3 dB bandwidth	130 kHz
Input impedance for channel ON	10 k Ω , 120 pF low pass filter

⁵ With signal source impedance < 2 k Ω . Refer to the Scanned Analog Input (Monitoring) section for more information about the influence of source impedance over accuracy.

⁶ Local ambient temperature. Refer to the Environmental section for more information about operating temperatures.

⁷ Range equals 5 V .

⁸ Offset error includes the effect of INL.

Input current for channel OFF	10 μ A maximum
Overvoltage protection	\pm 30 V maximum

Analog Output (Set-Point)

Number of channels	8
DAC resolution	12 bits
Startup voltage ⁹	0 V
Output range	
Typical	0 V to 5 V
Minimum	14 mV to 4.97 V
Current drive (per channel)	4 mA maximum
Update rate	1 kS/s maximum

Table 4. Accuracy

Measurement Conditions ¹⁰	Percent of Reading (Gain Error)	Percent of Range ¹¹ (Offset Error) ¹²
Maximum (-40 °C to 85 °C)	0.33%	0.28%
Typical (23 °C \pm 5 °C)	0.05%	0.06%

Figure 29. Absolute Accuracy Equation

$$\text{Absolute Accuracy} = \text{Output Value} \times \text{Gain Error} + \text{Range} \times \text{Offset Error}$$

Stability

Gain drift	6 ppm/°C
Offset drift	16 μ V/°C

Noise

1 MHz bandwidth	2.5 mVrms
100 kHz bandwidth	0.3 mVrms

⁹ The analog outputs may generate a short pulse of up to 300 mV for 100 μ s during power up.

¹⁰ Local ambient temperature. Refer to the Environmental section for more information about operating temperatures.

¹¹ Range equals 5 V.

¹² Offset error includes the effect of INL.

Protection

Overvoltage	+15 V/-5 V maximum
Short-circuit	Indefinitely

Sourcing Digital Input

Number of channels	28
Input type	Sourcing
Input range	0 V to 24 V
External power supply voltage range (VI P0, VI P1)	
Low-range mode	3 V to 6 V
High-range mode	10 V to 24 V
Not supported	6 V to 10 V
Digital logic levels	
Low-range mode	
OFF state	≥ 1.8 V minimum
ON state	≤ 1 V maximum
High-range mode	
OFF state	≥ 9.6 V minimum
ON state	≤ 7.9 V maximum
Hold time ¹³	0 s
Setup time ¹⁴	1 μ s minimum
Update/transfer time	3 μ s maximum
Pull-up resistor	4.70 k Ω
Overvoltage protection (VI P0, VI P1 to channel)	± 30 V maximum

Sinking Digital Output

Number of channels	24
Output type	Sinking
Startup voltage	Open

¹³ Hold time is the amount of time input signals must be stable after initiating a read from the NI 9684.

¹⁴ Setup time is the amount of time input signals must be stable before reading from the NI 9684.

Output voltage (V_O)

$$I_o \times R_o$$

Continuous output current (I_O) on each channel	20 mA
-----------------------------------------------------	-------

Output impedance (R_O)	6 Ω maximum
----------------------------	--------------------

External power supply voltage range	0 V to 30 V
-------------------------------------	-------------

Maximum update time	50 μ s
---------------------	------------

Protection

Reversed-voltage	None
------------------	------

Short-circuit	None
---------------	------

Half-Bridge Digital Output

Number of channels	14
--------------------	----

Output type	Sourcing/Sinking
-------------	------------------

Startup voltage	0 V
-----------------	-----

Maximum continuous output current	10 mA
-----------------------------------	-------

Output impedance (R_O)	105 Ω maximum
----------------------------	----------------------

External power supply voltage range (V_{ext})	5 V to 30 V
---------------------------------------------------	-------------

Digital logic levels¹⁵

High (V_{OH})

Sourcing 0.1 mA	$V_{ext} - 0.01V$
-----------------	-------------------

Sourcing 10 mA	$V_{ext} - 1.05 V$
----------------	--------------------

Low (V_{OL})

Sinking 0.1 mA	0.01 V
----------------	--------

Sinking 10 mA	1.05 V
---------------	--------

¹⁵ Digital logic levels are derived from the sinking/sourcing current multiplied by R_O .

Figure 30. Maximum Switching Frequency Based on the Capacitive Load

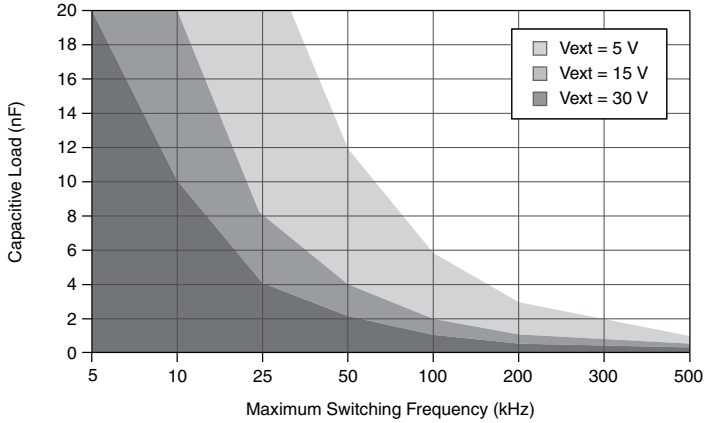
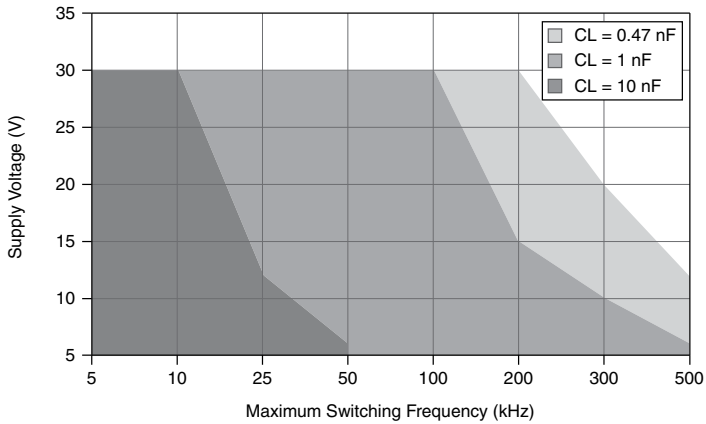

Figure 31. Maximum Switching Frequency Based on the Supply Voltage



Propagation delay

Vext = 5 V, CL = 50 pF 300 ns maximum

Vext > 15 V, CL = 50 pF 100 ns maximum

Protection

Overcurrent None

Short-circuit None

Relay Control Digital Output

Relay control DO specifications assume the use of direct board-to-board connections to I/O connectors on the NI 9684.

Number of channels	4
Output type	Sinking
Startup voltage	Open
External power supply voltage range	0 V to 30 V
Continuous current	500 mA
Maximum inrush current	8 A
Maximum inrush time	300 ms
Turn ON rate ¹⁶	One operation per 60 s
Turn ON time	6 ms maximum
Turn OFF time	0.2 ms maximum
Protection	
Reversed-voltage	None
Short-circuit	None

LVTTL Digital Input/Output

Number of channels	32
Maximum tested current (per channel)	3 mA
Maximum total current (all lines)	96 mA



Note The performance of the LVTTL DIO lines is bound by the FPGA, signal integrity, the applications timing requirements, and your design. For more information on using DIO to connect to RMCs, visit ni.com/info and enter the Info Code RMCDIO.

CMOS Battery



Note The battery is user-replaceable. The NI 9684 ships with a BR2032 coin cell battery from RAYOVAC, which is industrial-rated. Ensure that power remains connected to the NI 9684 while you replace the battery so that time-keeping is not

¹⁶ Turn ON rate is the minimum time between inrush current events and is based on the maximum inrush current over the maximum inrush time. You can turn OFF the relay control DO at any point during operation.

disrupted. Refer to the *Battery Replacement and Disposal* section for information about replacing the battery.

Typical battery life with power applied to power connector	10 years
Typical battery life in storage at 55 °C	2.5 years ¹⁷

Power Requirements

Power consumption from NI Single-Board RIO device	2 W maximum
Power-up time	0.1 s

Safety Voltages

Maximum Voltage

Connect voltages that are within the following limits.

Relay control digital output

Relay control DO+ to Relay control DO-	0 VDC to 30 VDC
----------------------------------------	-----------------

Relay control DO+/- to GND	±30 VDC
----------------------------	---------

Sinking digital output

DO-to-GND	±30 VDC
-----------	---------

Simultaneous analog input, scanned analog input, analog output, sourcing digital input

Pin-to-pin or pin-to-GND	±30 VDC
--------------------------	---------

Half-bridge digital output

Vext-to-GND	0 VDC to 30 VDC
-------------	-----------------

LVTTL digital input/output

	0 VDC to 3.465 VDC
--	--------------------

Isolation Voltages

Simultaneous analog input

Channel-to-channel	None
--------------------	------

Channel-to-common

Continuous	60 VDC, Measurement Category I
------------	--------------------------------

Withstand	1,000 Vrms
-----------	------------

Measurement Category I is for measurements performed on circuits not directly connected to the electrical distribution system referred to as *MAINS* voltage. *MAINS* is a hazardous live

¹⁷ Battery life may drop dramatically in extreme temperatures.

electrical supply system that powers equipment. This category is for measurements of voltages from specially protected secondary circuits. Such voltage measurements include signal levels, special equipment, limited-energy parts of equipment, circuits powered by regulated low-voltage sources, and electronics.



Caution Do not connect the NI 9684 to signals or use for measurements within Measurement Categories II, III, or IV.

Environmental

Operating temperature¹⁸ (IEC 60068-2-1, IEC 60068-2-2)

Ambient temperature outside a 12 in. × 10 in. × 6.34 in. enclosure	-40 °C to 50 °C
--------------------------------------------------------------------	-----------------

Ambient temperature with forced-air cooling in an open environment	-40 °C to 70 °C
--------------------------------------------------------------------	-----------------



Note Visit ni.com/info and enter the Info Code `sbRIOcooling` for information about NI sbRIO operating temperatures.

Storage temperature (IEC 60068-2-1, IEC 60068-2-2)	-40 °C to 85 °C
----------------------------------------------------	-----------------

Operating humidity (IEC 60068-2-78)	10% RH to 90% RH, noncondensing
-------------------------------------	---------------------------------

Storage humidity (IEC 60068-2-78)	5% RH to 95% RH, noncondensing
-----------------------------------	--------------------------------

Pollution Degree	2
------------------	---

Maximum altitude	2,000 m
------------------	---------

Indoor use only.

Physical Characteristics

Weight	153 g
--------	-------

Environmental Management

NI is committed to designing and manufacturing products in an environmentally responsible manner. NI recognizes that eliminating certain hazardous substances from our products is beneficial to the environment and to NI customers.

For additional environmental information, refer to the *Minimize Our Environmental Impact* web page at ni.com/environment. This page contains the environmental regulations and directives with which NI complies, as well as other environmental information not included in this document.

¹⁸ Ensure that the local ambient temperature of the NI 9684 is -40 °C to 85 °C. Measure the local ambient temperature by placing thermocouples on both sides of the PCB, 5 mm (0.2 in.) from the board surface.

Waste Electrical and Electronic Equipment (WEEE)



EU Customers At the end of the product life cycle, all NI products must be disposed of according to local laws and regulations. For more information about how to recycle NI products in your region, visit ni.com/environment/weee.

Battery Replacement and Disposal



Battery Directive This device contains a long-life coin cell battery. If you need to replace it, use the Return Material Authorization (RMA) process or contact an authorized National Instruments service representative. For more information about compliance with the EU Battery Directive 2006/66/EC about Batteries and Accumulators and Waste Batteries and Accumulators, visit ni.com/environment/batterydirective.

电子信息产品污染控制管理办法（中国 RoHS）



中国客户 National Instruments 符合中国电子信息产品中限制使用某些有害物质指令 (RoHS)。关于 National Instruments 中国 RoHS 合规性信息，请登录 ni.com/environment/rohs_china。(For information about China RoHS compliance, go to ni.com/environment/rohs_china.)

Worldwide Support and Services

The NI website is your complete resource for technical support. At ni.com/support, you have access to everything from troubleshooting and application development self-help resources to email and phone assistance from NI Application Engineers.

Visit ni.com/services for NI Factory Installation Services, repairs, extended warranty, and other services.

Visit ni.com/register to register your NI product. Product registration facilitates technical support and ensures that you receive important information updates from NI.

A Declaration of Conformity (DoC) is our claim of compliance with the Council of the European Communities using the manufacturer's declaration of conformity. This system affords the user protection for electromagnetic compatibility (EMC) and product safety. You can obtain the DoC for your product by visiting ni.com/certification. If your product supports calibration, you can obtain the calibration certificate for your product at ni.com/calibration.

NI corporate headquarters is located at 11500 North Mopac Expressway, Austin, Texas, 78759-3504. NI also has offices located around the world. For telephone support in the United States, create your service request at ni.com/support or dial 1 866 ASK MYNI (275 6964). For telephone support outside the United States, visit the *Worldwide Offices* section of ni.com/global to access the branch office websites, which provide up-to-date contact information, support phone numbers, email addresses, and current events.

Information is subject to change without notice. Refer to the *NI Trademarks and Logo Guidelines* at ni.com/trademarks for information on NI trademarks. Other product and company names mentioned herein are trademarks or trade names of their respective companies. For patents covering NI products/technology, refer to the appropriate location: **Help»Patents** in your software, the `patents.txt` file on your media, or the *National Instruments Patent Notice* at ni.com/patents. You can find information about end-user license agreements (EULAs) and third-party legal notices in the `readme` file for your NI product. Refer to the *Export Compliance Information* at ni.com/legal/export-compliance for the NI global trade compliance policy and how to obtain relevant HTS codes, ECCNs, and other import/export data. NI MAKES NO EXPRESS OR IMPLIED WARRANTIES AS TO THE ACCURACY OF THE INFORMATION CONTAINED HEREIN AND SHALL NOT BE LIABLE FOR ANY ERRORS. U.S. Government Customers: The data contained in this manual was developed at private expense and is subject to the applicable limited rights and restricted data rights as set forth in FAR 52.227-14, DFAR 252.227-7014, and DFAR 252.227-7015.

© 2017—2018 National Instruments. All rights reserved.

378017C-01 October 29, 2018