

# 1000W Electric Vehicle Charger Data Sheet



Green Watt/Powerland's 1000W Li-ion battery chargers are designed with ultra-high efficiency. The extraordinary performance of low power dissipation provides the charger with high reliability and long lifetime. This series of chargers offer solid and safe power conversions for applications such as e-vehicles, e-motorcycles, e-boat, e-machines, etc.

## Features:

- Universal AC Input (90~264Vac)
- Output Power: 1000W
- Output Voltage Range (40~84V). Typical is 72Vo
- Ultra-high Reliability
- High Efficiency: 93% typical @230Vac, full load
- All-around Protections: OVP, OCP, SCP, OTP, RCP
- Low Temperature Start Up @-20°C
- Charge stage indicator
- IP65
- CAN communication



## General Specifications

Model Number*	EVC-84-1000 (PLD1000-EVCM01-8312)	EVC-72-1000 (PLD1000-EVCM01-7414)
Output Voltage Range	40-84V	30~72V
Output Current (Max)	8.4A@115Vac 12A@230Vac	10A@115Vac 14A@230Vac
Output Current (Min)	0.4A	0.4A
Max. Output Voltage	84V	72V
Current Accuracy	±0.5A	±0.5A
Voltage Accuracy	±0.3V	±0.3V
Output Power	1008W	1036W
Input Voltage	90~264Vac	90~264Vac
Input Frequency	47~63Hz	47~63Hz
Max. Input Current	8A max. @25oC 115Vac input & Full load 5A max. @25oC 230Vac input & Full load	8A max. @25oC 115Vac input & Full load 5A max. @25oC 230Vac input & Full load
Power Factor (Typical)	>0.98@115Vac >0.97@230Vac	>0.98@115Vac >0.97@230Vac
Efficiency (Typical)	90%@115Vac 93%@230Vac	90%@115Vac 93%@230Vac
Ripple & Noise	Current Ripple: ±15% lout max., during constant current mode. Measurement is done by 20MHz bandwidth oscilloscope. (Test under the condition of rated input and rated output.)	Current Ripple: ±15% lout max., during constant current mode. Measurement is done by 20MHz bandwidth oscilloscope. (Test under the condition of rated input and rated output.)
Protections	OVP, OCP, SCP, OTP, RCP, Timer, Auto Off @No Load	OVP, OCP, SCP, OTP, RCP, Timer, Auto Off @No Load
OVP Range	The charger enters auto recovery mode when the output voltage is between 88V and 98V	The charger enters auto recovery mode when the output voltage is between 78V and 88V

Battery Under-voltage Protection	The charger shall not output if the sensed battery voltage is lower than 38V±2V	The charger shall not output if the sensed battery voltage is lower than 32V±2V
Anti -Reverse Polarity Protection	When the battery polarity is reversely connected to the charger, the charger shall not output	When the battery polarity is reversely connected to the charger, the charger shall not output
Communication Fault Protection	When there is communication fault between charger and BMS, the charger shall not output	When there is communication fault between charger and BMS, the charger shall not output
Timing Protection	When the charging time is over 12 hours, the charger shall shut down	When the charging time is over 12 hours, the charger shall shut down
Over-temperature Protection	The charger shall go into thermal protection when the maximum temperature of the case exceeds 70±5°C. The charger shall enter auto recovery mode, and shall be self-recovery when the temperature goes down to 55±5°C	The charger shall go into thermal protection when the maximum temperature of the case exceeds 70±5°C. The charger shall enter auto recovery mode, and shall be self-recovery when the temperature goes down to 55±5°C
Operating Temperature	-20~55°C The charger shall go into thermal protection when the maximum temperature of the case exceeds 70±5°C. The charger shall enter auto recovery mode, and shall be self-recovery when the temperature goes down to 55±5°C	-20~55°C The charger shall go into thermal protection when the maximum temperature of the case exceeds 70±5°C. The charger shall enter auto recovery mode, and shall be self-recovery when the temperature goes down to 55±5°C
Max. Case Temperature	<60°C@25°C Ambient Temperature	<60°C@25°C Ambient Temperature
Cooling	Fan Cooling	Fan Cooling
Relative Humidity	10% to 85% RH	10% to 85% RH
Storage Temperature & Relative Humidity Storage	-15~85°C 5% to 95%RH	-15~85°C 5% to 95%RH
Turn-on Delay	5.0s max. @ Full Load	5.0s max. @ Full Load
Ingress Protection Grade	IP65 (excluding connectors and fan)	IP65 (excluding connectors and fan)
Surge Protection	1kV DM / 2kV CM	1kV DM / 2kV CM
Isolation (Hi-pot)	Primary to Secondary: 3000Vac/10mA max./60s Primary to Earth: 1500Vac/10mA max./60s Secondary to Earth: 500Vac/10mA max./60s	Primary to Secondary: 3000Vac/10mA max./60s Primary to Earth: 1500Vac/10mA max./60s Secondary to Earth: 500Vac/10mA max./60s
Leakage Current	0.75mA max @264Vac 50Hz	0.75mA max @264Vac 50Hz
Dimensions (LxWxH)	210x160x51mm; 8.3x6.3x2.0in.	210x160x51mm; 8.3x6.3x2.0in.
Weight	3.0kg	3.0kg
MTBF/Life Time	The MTBF shall be at least 100,000 hours at 25°C, full load and nominal input condition. The life time shall be at least 15,000 hours at 25°C ambient temperature, full load and nominal input condition.	The MTBF shall be at least 100,000 hours at 25°C, full load and nominal input condition. The life time shall be at least 15,000 hours at 25°C ambient temperature, full load and nominal input condition.
Vibration	Design Verification: Vibration Operation, 0.01g <sup>2</sup> /Hz at 5 Hz sloping to 0.02g <sup>2</sup> /Hz at 20 Hz, and maintaining 0.02g <sup>2</sup> /Hz from 20 Hz to 500 Hz. The area under the PSD curve is 3.13gRMS. The duration shall be 20 minutes per axis for all three axes.	Design Verification: Vibration Operation, 0.01g <sup>2</sup> /Hz at 5 Hz sloping to 0.02g <sup>2</sup> /Hz at 20 Hz, and maintaining 0.02g <sup>2</sup> /Hz from 20 Hz to 500 Hz. The area under the PSD curve is 3.13gRMS. The duration shall be 20 minutes per axis for all three axes.
Agency Approval	Designed to meet EN60335	Designed to meet EN60335

\*Factory Model Number is in parenthesis

<b>Electromagnetic Compatibility EMI/EMC</b>	
<b>EMI, RFI</b>	Designed to meet EN55032 Class B
<b>Immunity:</b>	
EN61000-3-2	Harmonic Current Emission
EN61000-3-3	Voltage Fluctuations and Flicker
EN61000-4-2	ESD 8kV Air Discharge, 4kV Contact Discharge, Criteria A
EN61000-4-3	Radio-frequency Electromagnetic Field Susceptibility Test-Rs Level 3, Criteria A
EN61000-4-4	Electrical Fast Transient/ Burst-EFT 1KV
EN61000-4-5	Surge Immunity Test, AC Power line: Line to Line 2kV; Line to Earth 4kV Criteria B
EN61000-4-6	Conducted Radio Frequency Disturbance Test-Cs Level 3, Criteria A
EN61000-4-8	Power Frequency Magnetic Field Test 3A/m, Criteria A
EN61000-4-11	Voltage Dips Criteria B

**Typical Charge Curve & 72V Battery typical:**

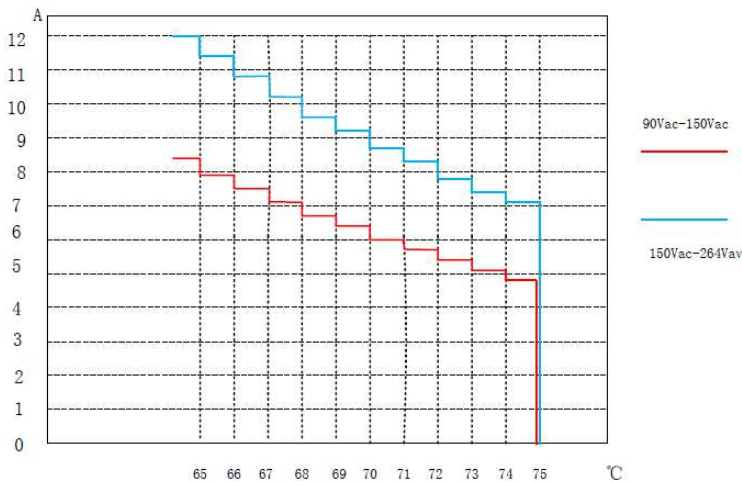

**Typical Charge Curve & 60V Battery typical:**

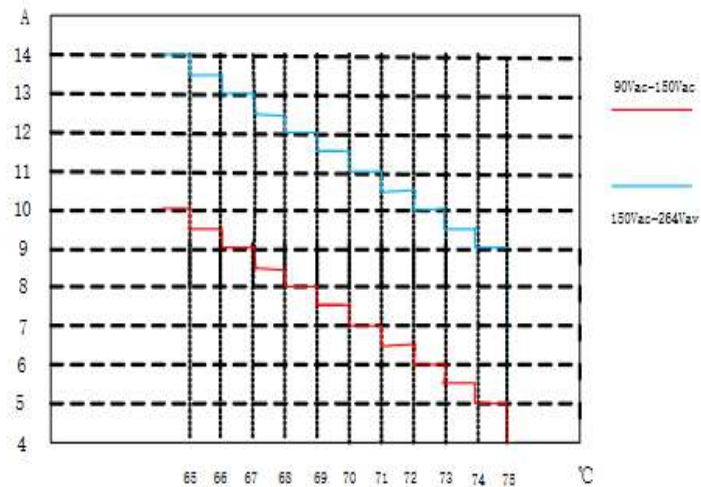

**Notes:**

- When the BMS board sends a command to inform the completion of charging, the LED color shall change to continuous green.
- The cut-off current is 200~600mA. When charging is finished, the LED color shall change from flashing red to continuous green.

## MECHANICAL

### Dimension and Outline Drawing

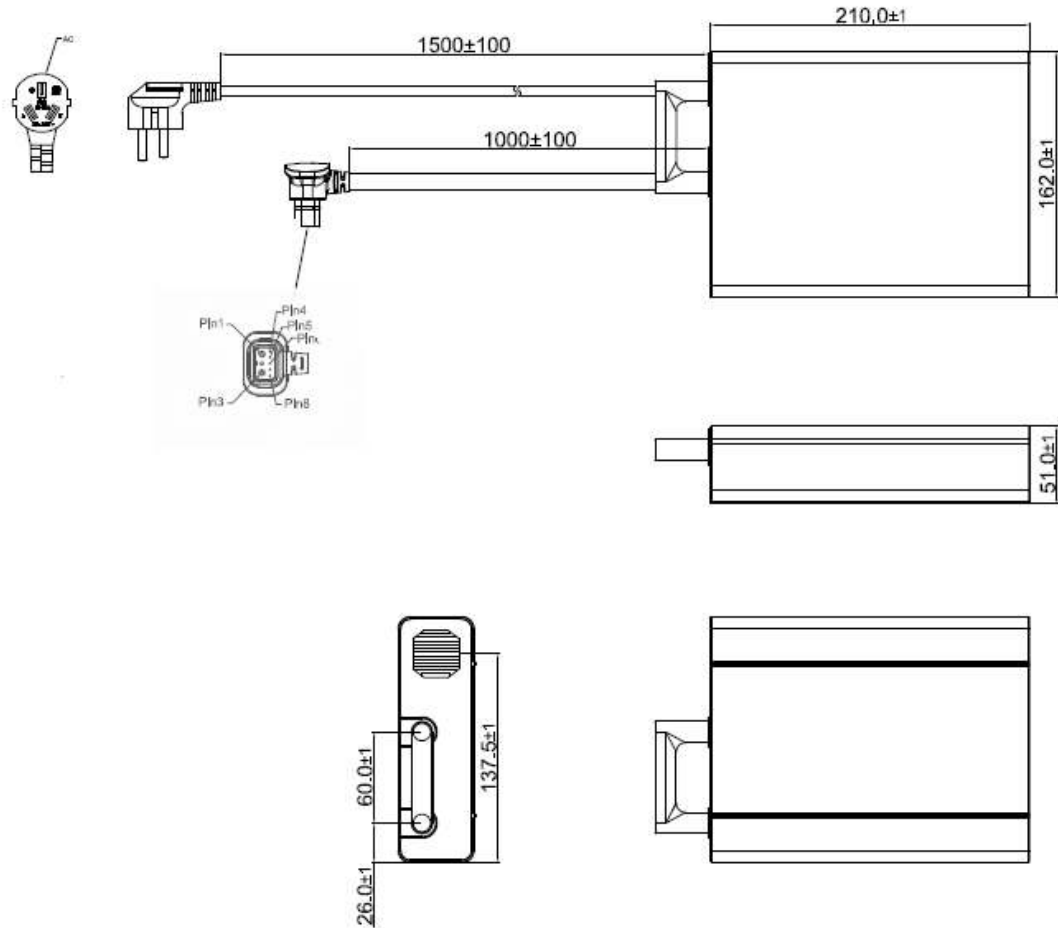

#### Output Connector Information:

Male connector: SINGATRON 2BW3100-W06301H

Female connectors: SINGATRON 2BA3W01-011114H

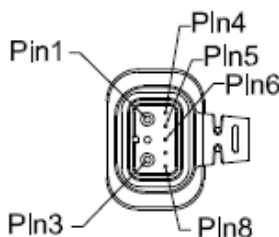

PIN	Function	Color of Cable	Notes
1	+1.5mm <sup>2</sup>	Red	PIN1 and PIN4 are short circuited internally
2	Not connected		
3	-1.5mm <sup>2</sup>	Black	PIN3 and PIN8 are short circuited internally
4	Not connected		
5	CANH 0.3mm <sup>2</sup>	Black	
6	CANL 0.3mm <sup>2</sup>	White	
7	Not connected		
8	Not connected		

#### AC Plug Information:

TOONG YEAN (<http://en.toongyea-tech.com>) TY-013 220V connector is supplied, 115V connector is responsibility of customer