

## **Ku-band 40W GaN BUC**

RF Frequency:

13.75 to 14.5 GHz and 14.0 to 14.5 GHz

### Model No. NJT8371 series

RF Frequency : 14.0 to 14.5 GHz / 13.75 to 14.5 GHz  
LO Frequency : 13.05 GHz / 12.80 GHz  
IF Frequency : 950 to 1,450 MHz / 950 to 1,700 MHz  
Saturation Output Power : +46 dBm (40W)  
IF / Ref. (10MHz) Input: N-type / F-type, Female Connector  
DC Power Input : MS Connector  
M&C Option : FSK Communication M&C  
RS-232C Interface M&C

## Specifications

Rev.02 January 26, 2018

## **Copyright 2018**

New Japan Radio Co., Ltd.  
Microwave Division

-Notice of Proprietary Information-

Documents and contents are proprietary to New Japan Radio Co., Ltd.  
This publication and its contents may not be reproduced or distributed for any other purpose without the written permission of New Japan Radio Co., Ltd.



## Caution

1. NJRC strives to produce reliable and high quality microwave components. NJRC's microwave components are intended for specific applications and require proper maintenance and handling. To enhance the performance and service of NJRC's microwave components, the devices, machinery or equipment into which they are integrated should undergo preventative maintenance and inspection at regularly scheduled intervals. Failure to properly maintain equipment and machinery incorporating these products can result in catastrophic system failures.
2. To ensure the highest levels of reliability, NJRC products must always be properly handled. The introduction of external contaminants (e.g. dust, oil or cosmetics) can result in failures of microwave components.
3. NJRC offers a variety of microwave components intended for particular applications. It is important that you select the proper component for your intended application. You may contact NJRC's sales office or sales representatives, if you are uncertain about the products listed in the catalog and the specification sheets.
4. Special care is required in designing devices, machinery or equipment, which demand high levels of reliability. This is particularly important when designing critical components or systems whose foreseeable failure can result in situations that could adversely affect health or safety. In designing such critical devices, equipment or machinery, careful consideration should be given to, amongst other things, their safety design, fail-safe design, back-up and redundancy systems, and diffusion design.
5. The products listed in the catalog and specification sheets may not be appropriate for use in certain equipment where reliability is critical or where the products may be subjected to extreme conditions. You should consult our sales office or sales representatives before using the products in any of the following types of equipment.
  - \* Aerospace Equipment
  - \* Equipment Used in the Deep Sea
  - \* Power Generator Control Equipment (nuclear, steam, hydraulic)
  - \* Life Maintenance Medical Equipment
  - \* Fire Alarm/Intruder Detector
  - \* Vehicle Control Equipment (automobile, airplane, railroad, ship, etc.)
  - \* Various Safety Equipment
6. NJRC's products have been designed and tested to function within controlled environmental conditions. Do not use products under conditions that deviate from methods or applications specified in the catalog and specification sheets. Failure to employ NJRC's products in the proper applications can lead to deterioration, destruction or failure of the products. NJRC shall not be responsible for any bodily injury, fires or accidents, property damage or any consequential damages resulting from the misuse or misapplication of its products. **PRODUCTS ARE SOLD WITHOUT WARRANTY OF ANY OF KIND, EITHER EXPRESS OR IMPLIED, INCLUDING BUT NOT LIMITED TO ANY IMPLIED WARRANTY OF MERCHANTABILITY OR FITNESS FOR A PARTICULAR PURPOSE.**
7. The product specifications and descriptions listed in the catalog and specification sheets are subject to change at any time, without notice.

\* Above Specifications are subject to change without notice.

## Model Number[

### ● Numbering System

**N J T 8 3 7 1 U N M R A**

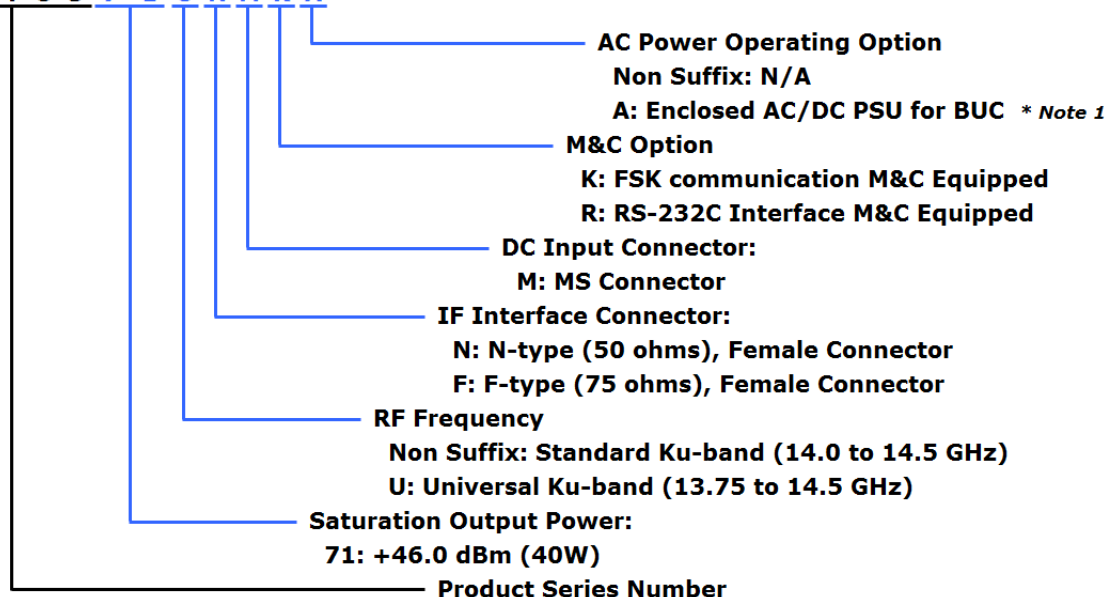

### ● Line-up

Model No.	RF Frequency	Local Frequency	IF Frequency	Output Power	IF Connector	Power Supply	Port for Voltage Input	M&C Option
NJT8371NMK	14.0 to 14.5 GHz (Standard Ku-band)	13.05 GHz	950 to 1,450 MHz	40W Saturation (+46dBm)	N-type	+36 to +60 V DC Power	MS Connector	FSK M&C
NJT8371FMK					F-type			
NJT8371NMKA					N-type	AC Power	MS Connector * Note 1	
NJT8371FMKA					F-type			
NJT8371NMR					N-type	+36 to +60 V DC Power	MS Connector	RS-232C M&C
NJT8371MRA					F-type			
NJT8371FMRA					N-type	AC Power	MS Connector * Note 1	
NJT8371UNMK					F-type			
NJT8371UFMK	13.75 to 14.5 GHz (Universal Ku-band)	12.80 GHz	950 to 1,700 MHz	40W Saturation (+46dBm)	N-type	+36 to +60 V DC Power	MS Connector	FSK M&C
NJT8371UNMKA					F-type			
NJT8371UFMKA					N-type	AC Power	MS Connector * Note 1	
NJT8371UNMR					F-type			
NJT8371UFMR					N-type	+36 to +60 V DC Power	MS Connector	RS-232C M&C
NJT8371UNMRA					F-type			
NJT8371UFMRA					N-type	AC Power	MS Connector * Note 1	
NJT8371UFMRA					F-type			

\*Note1: Additional outdoor 500W AC/DC PSU is enclosed for AC Power Option and DC Power is supplied at MS connector of BUC from AC/DC PSU via power cable.

\* Above Specifications are subject to change without notice.

## 1. Electrical Specifications

#	Items	Specifications
1-1.	Output Frequency Range	
	<Universal Ku-band>	13.75 to 14.5 GHz
	<Standard Ku-band>	14.0 to 14.5 GHz
1-2.	Input Frequency Range	
	<Universal Ku-band>	950 to 1,700 MHz
	<Standard Ku-band>	950 to 1,450 MHz
1-3.	Maximum IF Input Level (without damage)	+13 dBm max.
1-4.	Conversion Type	Single, fixed L.O.
1-5.	L.O. Frequency	
	<Universal Ku-band>	12.80 GHz
	<Standard Ku-band>	13.05 GHz
1-6.	Frequency Sense	Positive
1-7.	Saturation Output Power (P <sub>sat</sub> )	+46 dBm min. @ +25 °C +45 dBm min. over temperature
1-8.	Linear Gain	72 dB nom., 66 dB min.
1-9.	Gain Variation over frequency @ fixed temperature	
	<Universal Ku-band>	5 dBp-p max. over 750 MHz 2 dBp-p max. over 54 MHz
	<Standard Ku-band>	5 dBp-p max. over 500 MHz 2 dBp-p max. over 54 MHz
1-10.	Gain Stability over temperature @ fixed frequency	4 dBp-p max. 2 dBp-p typ.
1-11.	ACPR	-30 dBc typ., -26 dBc min. @ P <sub>out</sub> = +44 dBm
1-12.	Requirement for External Reference [Frequency] [Input Power] [Phase Noise]	10 MHz (sine-wave) -5 to +5 dBm @ Input port -125 dBc/Hz max. @ 100 Hz -135 dBc/Hz max. @ 1 kHz -140 dBc/Hz max. @ 10 kHz
1-13.	L.O. Phase Noise	-60 dBc/Hz max. @ 100 Hz -70 dBc/Hz max. @ 1 kHz -80 dBc/Hz max. @ 10 kHz -90 dBc/Hz max. @ 100 kHz -100 dBc/Hz max. @ 1MHz
1-14.	Spurious @ P <sub>out</sub> =+44dBm [in band] [in receive and] [Out-of-band]	-50 dBc max. @ RF Frequency -70 dBm max. @ 10.95 to 12.75 GHz -50 dBc max.
1-15.	Receive Band Noise Density <Universal Ku-band>	Tx: 14.0 to 14.5 GHz -156 dBm/Hz max. @10.95 to 12.75 GHz Tx: 13.75 to 14.0 GHz -156 dBm/Hz max. @10.95 to 12.25 GHz -121 dBm/Hz max.)@12.25 to 12.75 GHz
	<Standard Ku-band>	Tx: 14.0 to 14.5GHz -156 dBm/Hz max. @ 10.95 to 12.75 GHz
1-16.	Noise Figure	20 dB max.
1-17.	Group Delay over any 54MHz	2.5 nS p-p max.

\* Above Specifications are subject to change without notice.

#	Items	Specifications
1-18.	Input Impedance	
	<N-type Model>	50 ohms nom.
	<F-type Model>	75 ohms nom.
1-19.	Input V.S.W.R.	2 : 1 max.
1-20.	Output V.S.W.R.	1.5 : 1 max.
1-21.	Output Load VSWR for Non Damage	2 : 1 max.
1-22.	DC Power Requirement [Voltage Range] [Power Consumption]	+48 VDC (+36 to +60 VDC) 120 W typ. @ No IF signal 220 W typ. @ Pout=+44dBm 260 W typ., 290 W max. @ Psat
1-23.	Mute	Shut off the HPA in case of L.O. unlocked, no 10 MHz reference signal, or Over temperature. * Note 2
1-24.	LED Indicator	GREEN: L.O. locked RED: L.O. unlocked (or no 10 MHz reference signal)
1-25.	Monitor and Control <FSK Communication M&C> [Interface] [Functions]	650kHz FSK Signal on IF Connector Monitor: Tx Output Power / Temperature / Tx Status / Alarm (Over temperature * Note 1 / L.O. unlock) / Step Attenuator Control: Transmit On/Off / Step Attenuator
	[Performance]	Tx Output Power: Detector Range: 15 dB (up to Psat) Reading Accuracy: +/- 1.0 dB Step Attenuator: Attenuator Range: 0 to 31.5 dB Attenuator Step: 0.5 dB <i>*Details are mentioned on Appendix of "Specifications of Monitor &amp; Control".</i>
	<RS-232C Interface M&C > [Interface] [Functions]	RS-232C Interface on MS connector Monitor: Tx Output Power / Temperature / Tx Status / Alarm (Over temperature * Note 1 / L.O. unlock) / Step Attenuator Control: Transmit On/Off / Step Attenuator
	[Performance]	Tx Output Power: Detector Range: 15 dB (up to Psat) Reading Accuracy: +/- 1.0 dB Step Attenuator: Attenuator Range: 0 to 31.5 dB Attenuator Step: 0.5 dB <i>*Details are mentioned on Appendix of "Specifications of Monitor &amp; Control".</i>

\*Note2: Regardless of cooling fan status, the unit will operate until status of over temperature which turn out at internal temperature of around 100 °C, and the Mute and Alarm will function at status of over temperature.

\* Above Specifications are subject to change without notice.

## 2. Mechanical Specifications

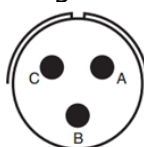
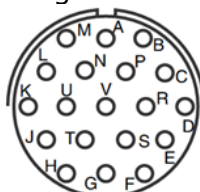
#	Items	Specifications
2-1.	Input Interface [IF Connector]  [Circular Connector]	<p>IF / Ref. / FSK M&amp;C Signal Input: N-type female connector, 50 ohms F-type female connector, 75 ohms</p> <p>DC Input: MS Connector Part No.: PT02E-12-3P (025) Mating connector: PT06E-12-3S (470) Assignment:</p>  <p><b>Pin A: DC Output (+) / Prime</b> <b>Pin B: Frame GND</b> <b>Pin C: DC Output (-) / Return</b></p> <p>M&amp;C Input: MS Connector * Part No.: PT02E-14-19P (025) Mating connector: PT06E-14-19S (470) Assignment:</p>  <p><b>Pin A: GND COMMON</b> <b>Pin B: GND COMMON</b> <b>Pin C: N.C.</b> <b>Pin D: N.C.</b> <b>Pin E: N.C.</b> <b>Pin F: GND COMMON</b> <b>Pin G: RS-232C RxD</b> <b>Pin H: RS-232C TxD</b> <b>Pin J: N.C.</b> <b>Pin K: N.C.</b> <b>Pin L: N.C.</b> <b>Pin M: N.C.</b> <b>Pin N: N.C.</b> <b>Pin P: N.C.</b> <b>Pin R: N.C.</b> <b>Pin S: N.C.</b> <b>Pin T: N.C.</b> <b>Pin U: N.C.</b> <b>Pin V: N.C.</b></p> <p><i>* This MS connector is available for only RS-232C Interface M&amp;C models.</i></p>
2-2.	Output Interface	Waveguide, WR-75 (with Groove)
2-3.	Cooling	Forced-air-cooled
2-4.	Dimension & Housing	230(L) × 150(W) × 100(H) mm [9.07" (L) × 5.12" (W) × 3.15" (H)] without interface connectors and screws
2-5.	Weight	4.2 kg [9.3 lbs]

\* Above Specifications are subject to change without notice.

### 3. Environmental Specifications

#	Items	Specifications
3-1.	Temperature Range (ambient) [Operating] [Storage]	-40 to +60 °C -40 to +75 °C
3-2.	Humidity	0 to 100 %
3-3.	Altitude	15,000 feet (4,572 m)
3-4.	Vibration	5 G [49.03 m/s <sup>2</sup> ] (3 axis, 50 Hz to 2 kHz) 1 mm p-p (3 axis, 5 to 50 Hz)
3-5.	Shock	30 G [294.20 m/s <sup>2</sup> ] (3 axis)
3-6.	Waterproof / Dustproof (IP Code)	IP 67
3-7.	Regulations	EU Directive (CE Marking) EMC (2014/30/EC) RoHS (2011/65/EU) Safety: EN60950-1
3-8.	Comply with RoHS (Restricting the use of Hazardous Substances) directives	

\* Above Specifications are subject to change without notice.

## 4. Outline Drawing

- IF / Ref. Input: N-type Female Connector
- DC Input: MS Connector
- M&C Option: RS-232C Interface M&C

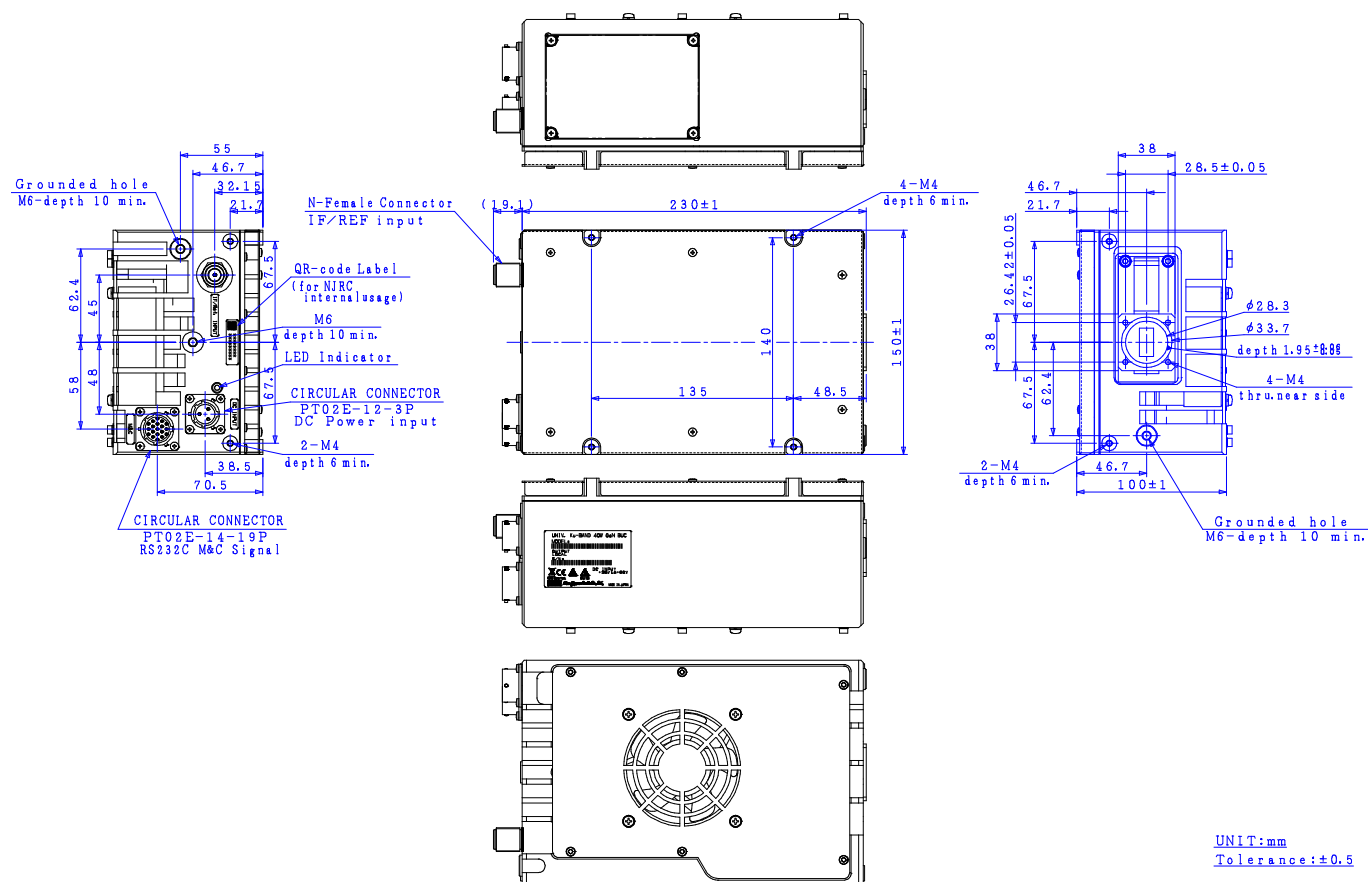

### Accessories

- O-ring, Qty (1), for waveguide flange
- Wrench Key, Qty (1), M4, Hexagon
- Bolts, Qty (4), M4 x 10, Hexagon socket head with spring washer and flat washer, SUS, for waveguide flange
- Screws, Qty (2), M6 x 10, Phillips head with spring washer and flat washer, SUS, for grounded hole
- Connector, Qty (1), MS Mating connector: PT06E-12-3S (470)
- Connector, Qty (1), MS Mating connector: PT06E-14-19S (470)

\* Above Specifications are subject to change without notice.



- IF / Ref. Input: F-type Female Connector
- DC Input: MS Connector
- M&C Option: RS-232C Interface M&C

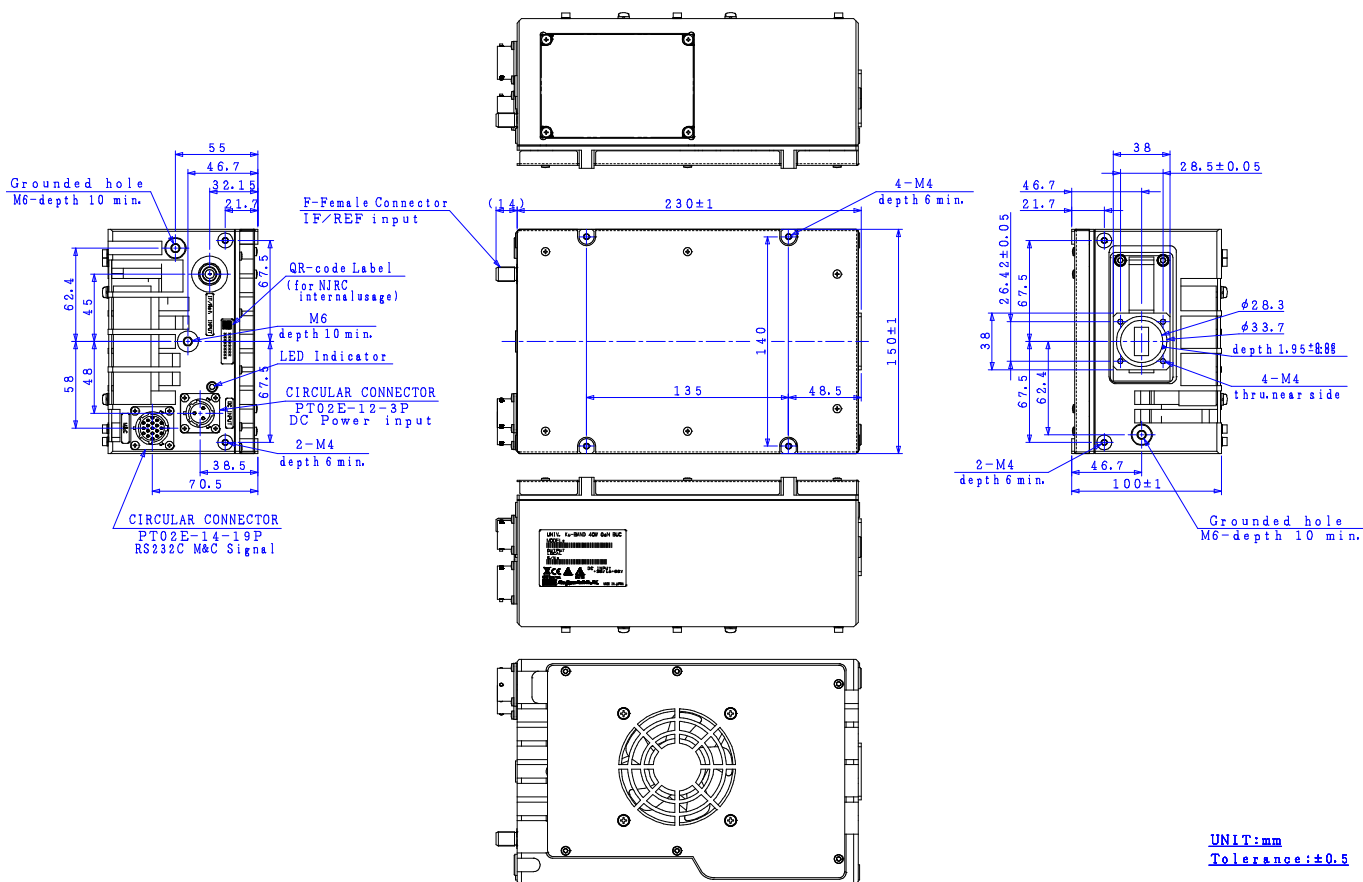

### Accessories

- O-ring, Qty (1), for waveguide flange
- Wrench Key, Qty (1), M4, Hexagon
- Bolts, Qty (4), M4 x 10, Hexagon socket head with spring washer and flat washer, SUS, for waveguide flange
- Screws, Qty (2), M6 x 10, Phillips head with spring washer and flat washer, SUS, for grounded hole
- Connector, Qty (1), MS Mating connector: PT06E-12-3S (470)
- Connector, Qty (1), MS Mating connector: PT06E-14-19S (470)

\* Above Specifications are subject to change without notice.

- IF / Ref. Input: N-type Female Connector
- DC Input: MS Connector
- M&C Option: FSK Communication M&C

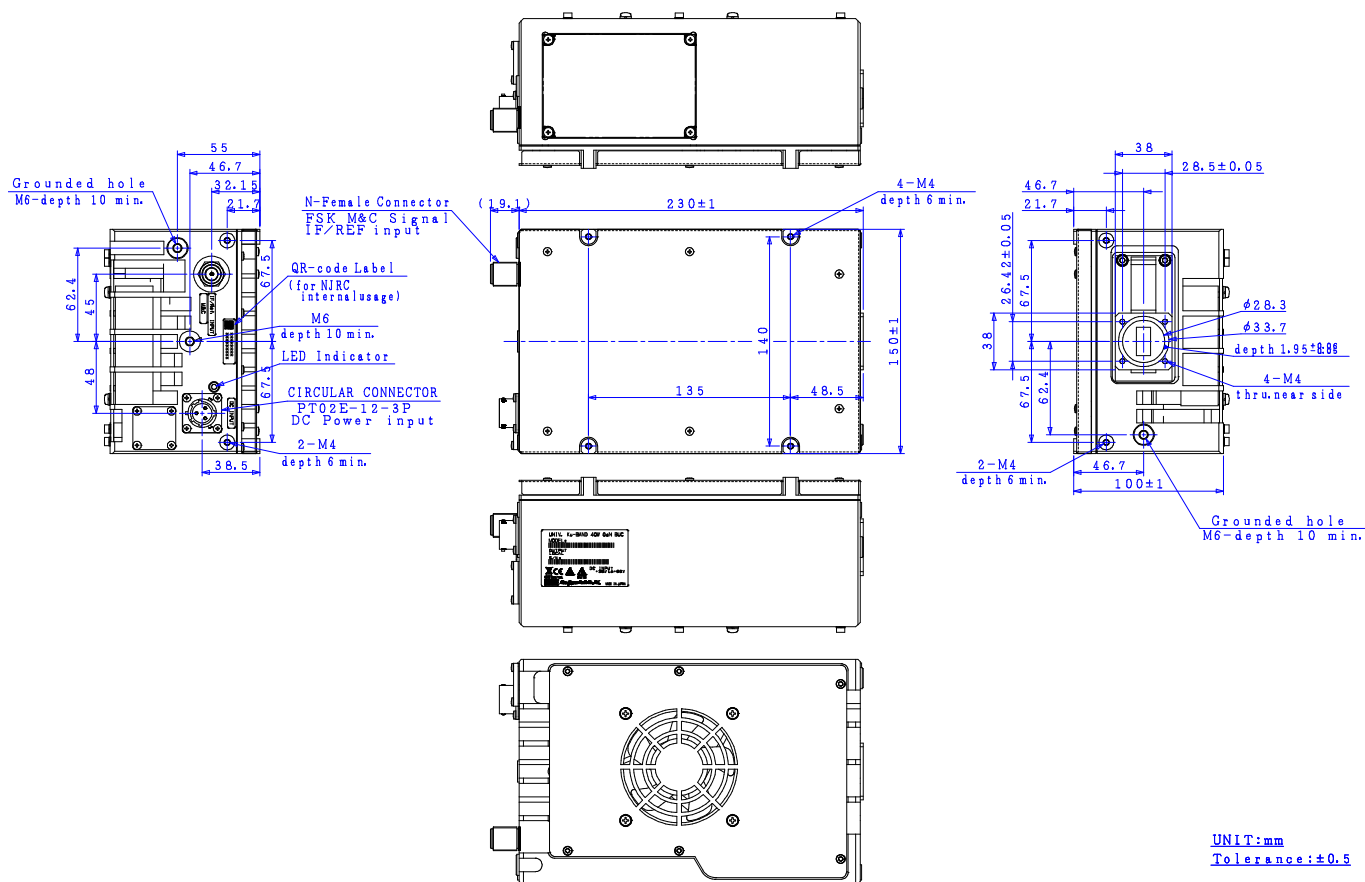

### Accessories

- O-ring, Qty (1), for waveguide flange
- Wrench Key, Qty (1), M4, Hexagon
- Bolts, Qty (4), M4 x 10, Hexagon socket head with spring washer and flat washer, SUS, for waveguide flange
- Screws, Qty (2), M6 x 10, Phillips head with spring washer and flat washer, SUS, for grounded hole
- Connector, Qty (1), MS Mating connector: PT06E-12-3S (470)

\* Above Specifications are subject to change without notice.

- IF / Ref. Input: F-type Female Connector
- DC Input: MS Connector
- M&C Option: FSK Communication M&C

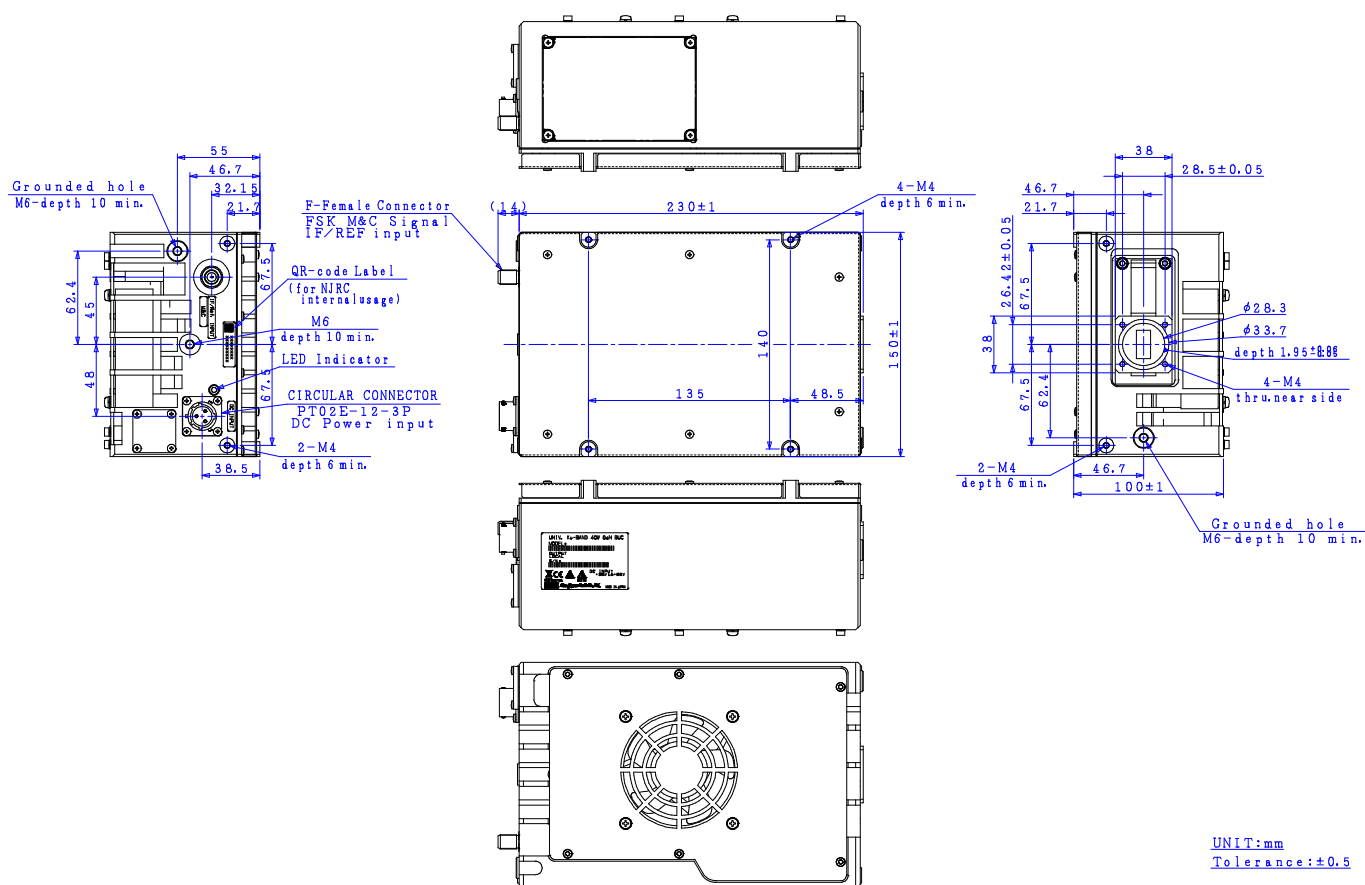

### Accessories

- O-ring, Qty (1), for waveguide flange
- Wrench Key, Qty (1), M4, Hexagon
- Bolts, Qty (4), M4 x 10, Hexagon socket head with spring washer and flat washer, SUS, for waveguide flange
- Screws, Qty (2), M6 x 10, Phillips head with spring washer and flat washer, SUS, for grounded hole
- Connector, Qty (1), MS Mating connector: PT06E-12-3S (470)

\* Above Specifications are subject to change without notice.

## 5. Label Product Label

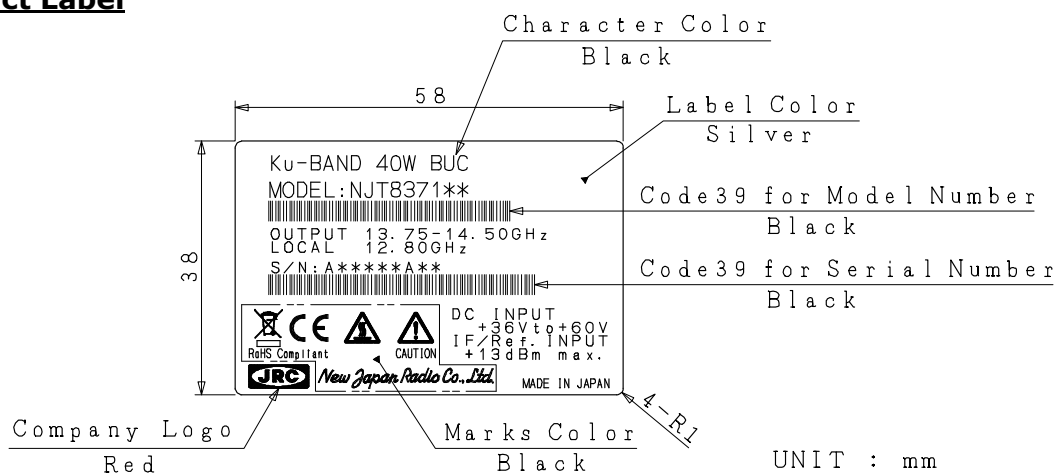

### Definition of Serial Number

Serial Number (OSSSSRYM) - ALPHANUMERIC (9 characters)

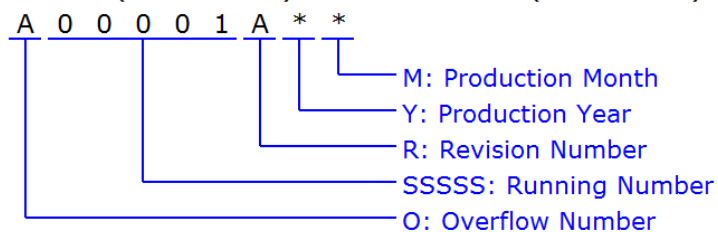

O: Overflow Number - ALPHABET (1 character)

"A" to "Z", e.g.: A99999 ⇒ B00001

SSSSS: Running Number - NUMBER (5 digits)

"00001" to "99999"

R: Revision Number - ALPHABET (1 character)

"A" to "Z"

Y: Production Year - NUMBER (1 digit)

Calendar Number, e.g.: 2009:9, 2010:0, 2011:1, 2012:2 ...

M: Production Month - ALPHANUMERIC (1 character)

"1" to "9", "X" as October, "Y" as November, "Z" as December

\* Above Specifications are subject to change without notice.

## 6. Package

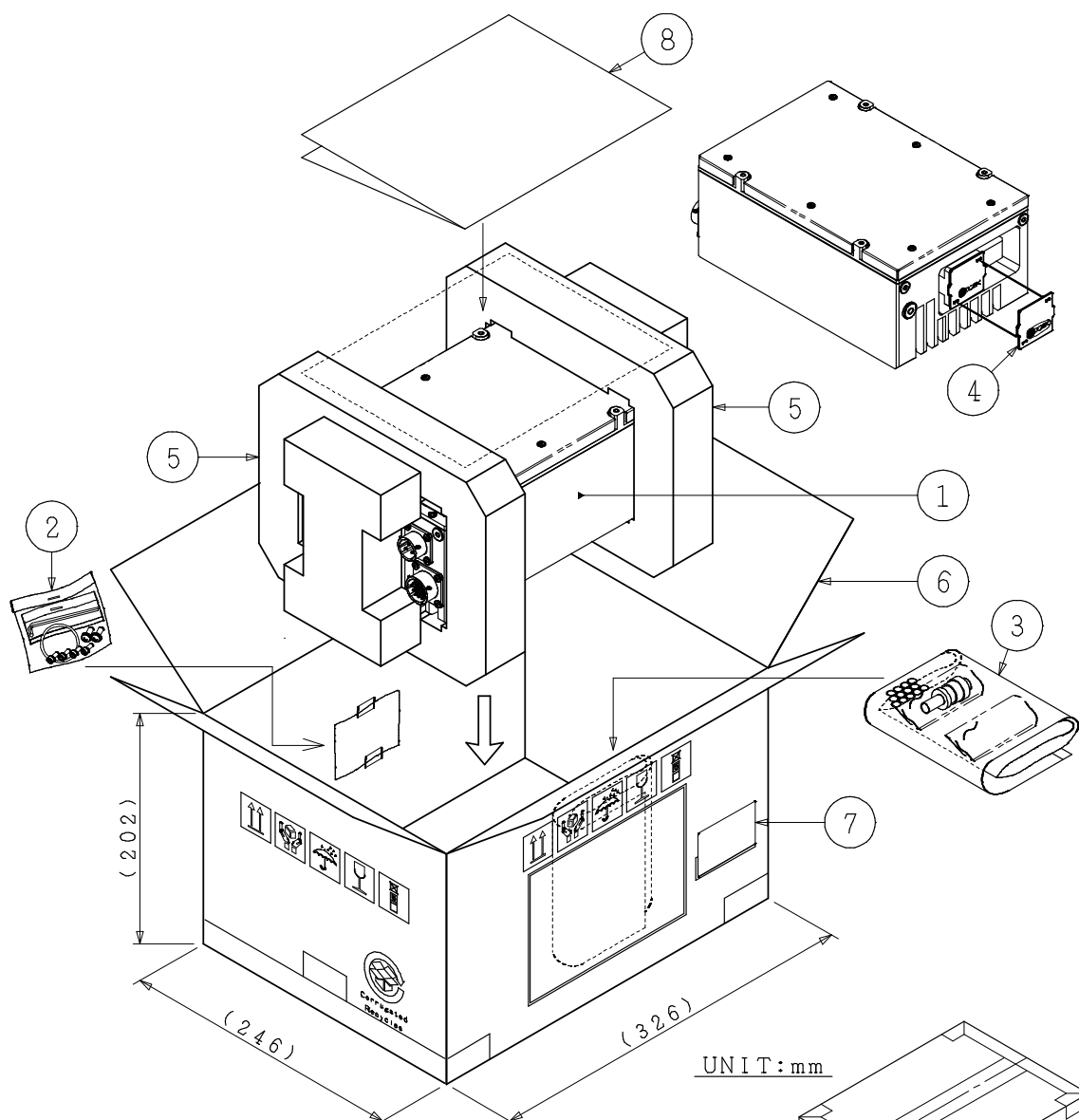

- ①: BUC
- ②: Accessories
- O-RING
  - Hexagon Socket Head Bolts  
M4×10 4 pieces (SUS, SW and W)  
for Waveguide Flange Holes
  - Hexagon Wrench Keys (M4 Type)
  - Cross Recessed Head Machine Screw  
M6×10 2 Piece (SUS, SW) for Ground Hole
- ③: Accessories
- MS mating connectors
- ④: Polypropylene Flange Cover
- ⑤: Polyethylene foam for package cushioning
- ⑥: Double-faced corrugated fiberboard
- ⑦: Label
- ⑧: Test Data

\* Above Specifications are subject to change without notice.

## 7. Reference Performance

**Output Power/Gain Compression vs. Input Power**

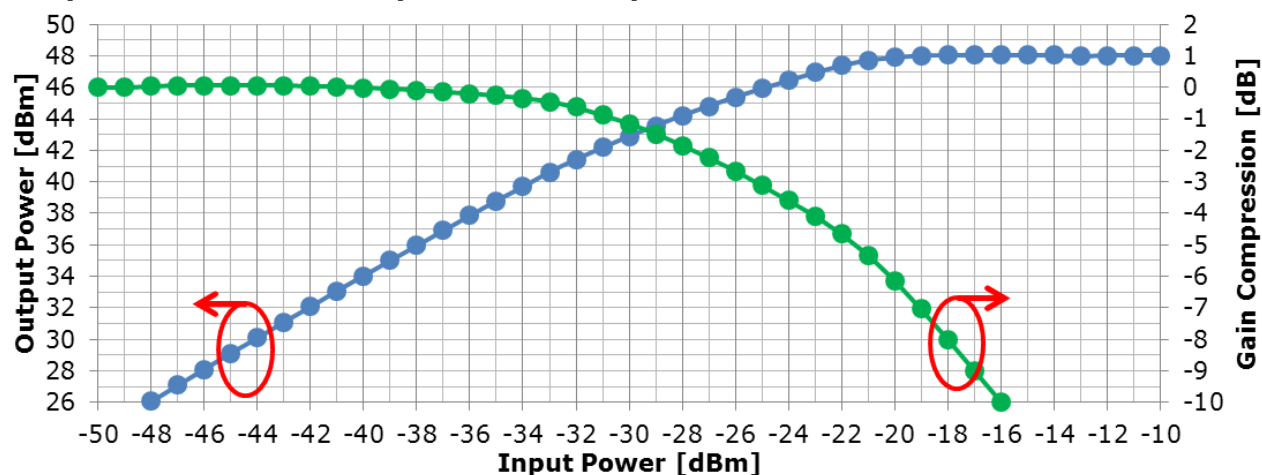

**Output Power/Power Consumption vs. Input Power**

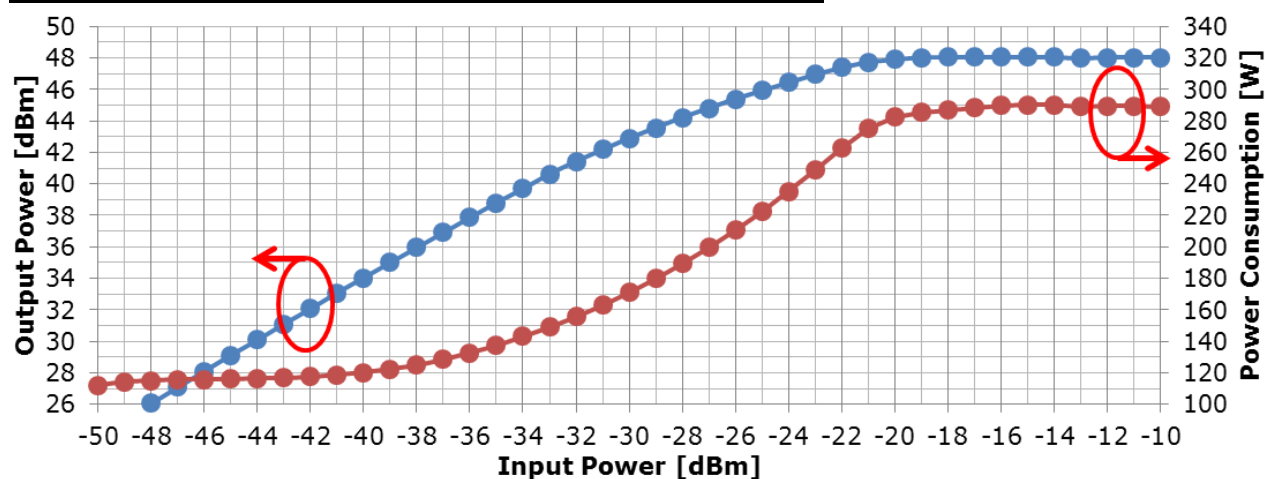

\* Above Specifications are subject to change without notice.

## AC Power Operating Option

### 1. Overview

The features of Outdoor 500W AC/DC Power Supply Unit (PSU) are to provide the stable +51V DC power to operate High Power BUCs, even if power supply of the equipment is not capable enough to operate the BUC.

This unit employs the aluminum housing with corrosion-proof treatment on the surface and has air-sealing structure in order to use perfectly as the outdoor unit.

In addition, the outdoor 500W AC/DC PSU complies with EU DIRECTIVE.

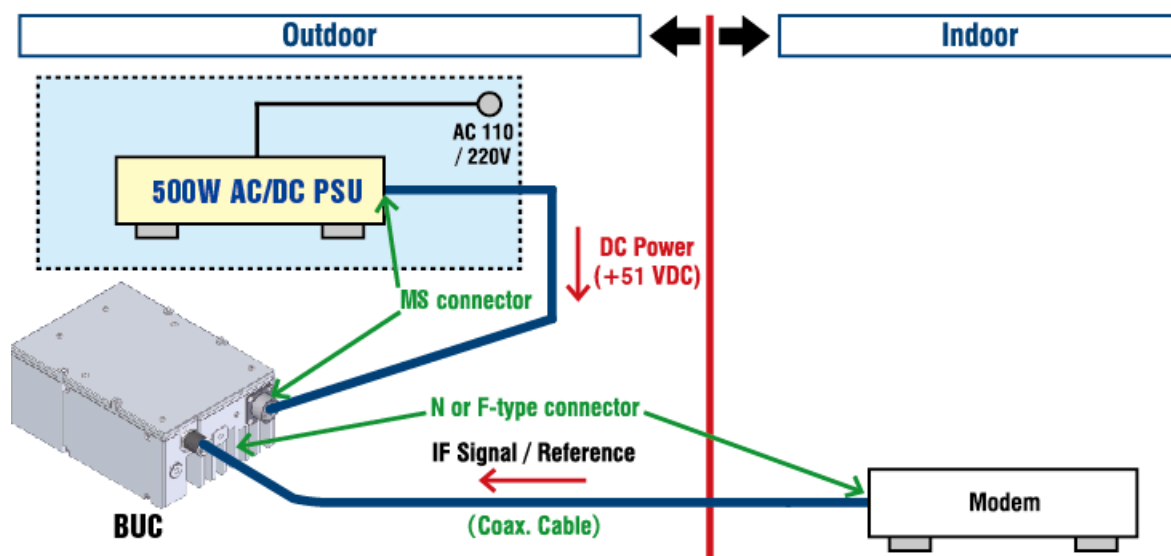

\* Above Specifications are subject to change without notice.

## AC Power Operating Option

### 2. Electrical Specifications

2-1.	Input AC Voltage Range [Rated Range] [Absolute Maximum Rating]	100 to 240 VAC 90 to 264 VAC
2-2.	Input AC Frequency Range	50/60 Hz
2-3.	Input AC Current	6 A max. @ 110V Input 3 A max. @ 230V Input
2-4.	Output Voltage	+51 VDC +/- 3 V
2-5.	Output Current	9.8 A max.(output:+51Vdc , 500W Load) @110V/230V Input * Note 3
2-6.	Maximum Output Power	500 W at 110V/230V Input * Note 3
2-7.	Efficiency	85 % typ. @ 110V Input & 500W Load 88 % typ. @ 230V Input & 500W Load * Note 4
2-8.	Power Factor	0.96 typ. @ 110V Input & 500W Load 0.93 typ. @ 230V Input & 500W Load * Note 4

\*Note3: The detail refers to a graph of the output power derating curve in below.

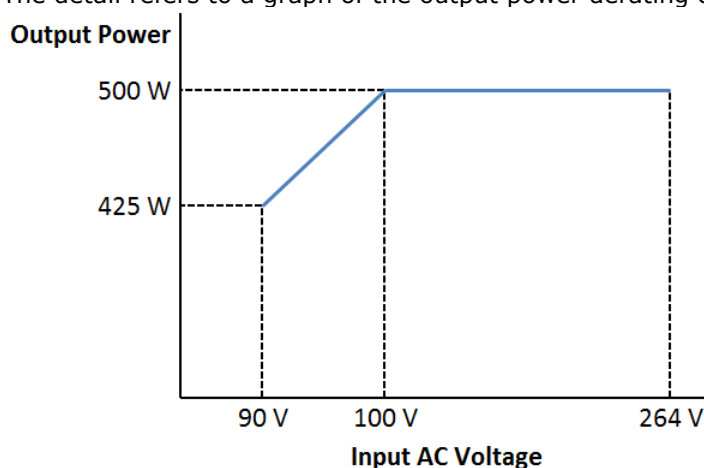

\*Note4: The condition is 110 and 230 VAC as AC voltage input and no FAN cycling.

\* Above Specifications are subject to change without notice.



## AC Power Operating Option

### 3. Mechanical Specifications

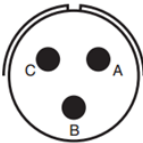
3-1.	Input Interface [AC Input]	AC Connector: GTS030-16-10P (025) Mating Connector: GTS06CF-16-10S (025) (Amphenol GT connector)  Assignment:  <p><b>Pin A: AC input (Live)</b>  <b>Pin B: Frame Ground (GND)</b>  <b>Pin C: AC input (Neutral)</b></p>
3-2.	Output Interface [DC & Option Output]	MS Connector: PT02E-12-3P (025) Mating Connector: PT06E-12-3S (470) (Amphenol PT connector)  Assignment:  <p><b>Pin A: DC Output (+) / Prime</b>  <b>Pin B: Frame GND</b>  <b>Pin C: DC Output (-) / Return</b></p>
3-3.	Dimension & Housing	250 (L) x 191 (W) x 118.1 (H) mm [9.84" (L) x 7.52" (W) x 4.65" (H)] without interface connectors and screws
3-4.	Weight	5.0 kg [11 lbs.]
3-5.	Surface Finish [Protective & Conformal Coating] [Finish Paint]	Trivalent Chromate Treatment Polyurethane Paint, Ivory Color
3-6.	Cooling	Forced-air-cooled

\* Above Specifications are subject to change without notice.

## AC Power Operating Option

### 4. Environmental Specifications

4-1.	Temperature Range (ambient) [Operating] [Storage]	-40 to +60 °C -40 to +75 °C
4-2.	Humidity	0 to 100 % Rh
4-3.	Altitude	4,572 m [15,000 ft]
4-4.	Dust/Waterproof	IP67 * Note 5
4-5.	Vibration	3.2 G [31.3 m/s <sup>2</sup> ] (3 axis, 10 Hz to 1 kHz) 1 mm p-p (3 axis, 5 to 50 Hz)
4-6.	Shock	30 G [294.20 m/s <sup>2</sup> ] (3 axis)
4-7.	Regulations	EU Directive (CE Marking) EMC Directive: 2014/30/EU Low Voltage Directive: 2014/35/EU
4-8.	Standard [Safety] [EMC]	IEC60950-1:2005+A1:2009+A2:2013 EN60950-1:2006+A11:2009+A1:2011+A12:2012+A2:2013 *Category and group : Overvoltage Category :II Pollution Degree :1 Material Group :IIIab EN61000-3-2 (Harmonic Current Emission Test) EN61000-3-3 (Voltage Fluctuations and Flicker Test) EN61000-4-2 (ESD Test) EN61000-4-3 (Radio-Frequency Electromagnetic Field Test) EN61000-4-4 (Electrical Fast Transient/Burst Test) EN61000-4-5 (Surge Test) EN61000-4-6 (Conducted Disturbance Radio-Frequency Test) EN61000-4-8 (Power Frequency Magnetic Field Test) EN61000-4-11 (Voltage Dips and Interruptions Test) EN55022-B (Disturbance Voltage Test)
4-9.	Comply with RoHS (Restricting the use of Hazardous Substances) directives	

\*Note5: Conditioned on connection with all of enclosed mating connectors.

### 5. Accessories

- AC Connector (Plug socket), Qty (1), Mating connector: GTS06CF-16-10S (025)
- MS Connector (Plug socket), Qty (1), Mating connector: PT06E-12-3S (470)

\* Above Specifications are subject to change without notice.

## AC Power Operating Option

### 6. Outline Drawing

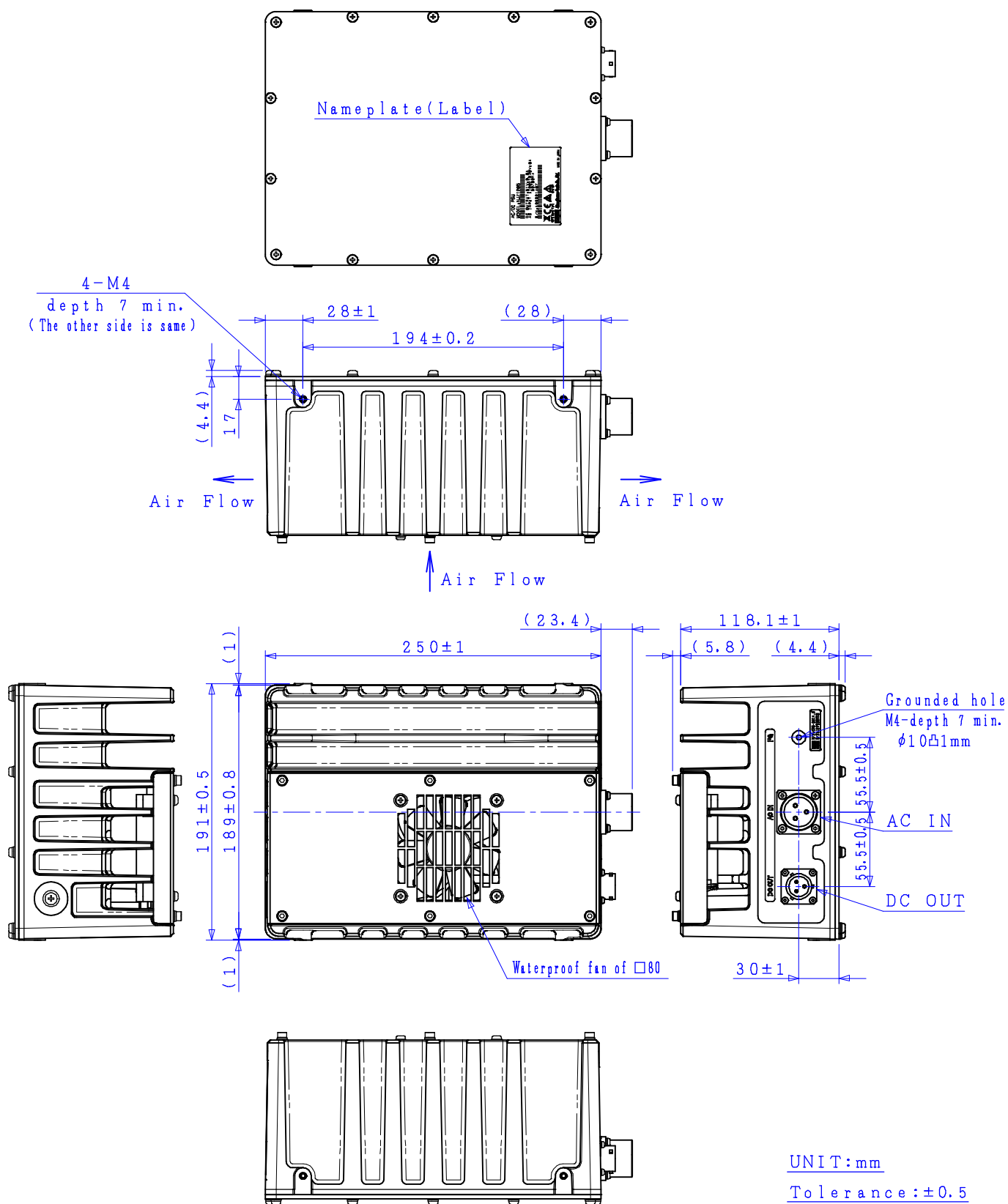

\* Above Specifications are subject to change without notice.

## AC Power Operating Option

### 7. Label

#### Product Label

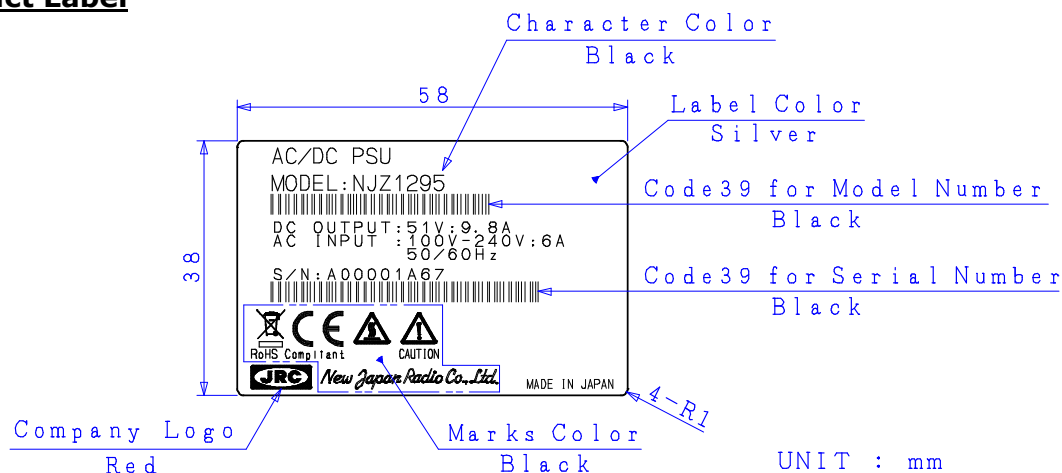

#### Definition of Serial Number

Serial Number (OSSSSSRYM) - ALPHANUMERIC (9 characters)

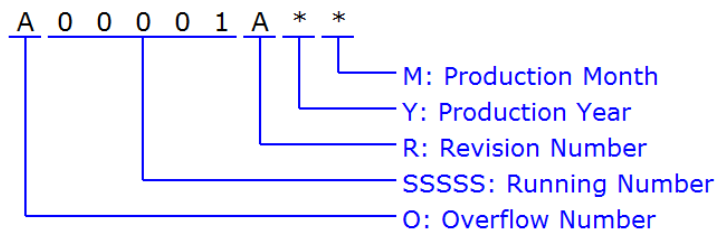

O: Overflow Number - ALPHABET (1 character)

"A" to "Z", e.g.: A99999 ⇒ B00001

SSSSS: Running Number - NUMBER (5 digits)

"00001" to "99999"

R: Revision Number - ALPHABET (1 character)

"A" to "Z"

Y: Production Year - NUMBER (1 digit)

Calendar Number, e.g.: 2009:9, 2010:0, 2011:1, 2012:2 ...

M: Production Month - ALPHANUMERIC (1character)

"1" to "9", "X" as October, "Y" as November, "Z" as December

\* Above Specifications are subject to change without notice.

## AC Power Operating Option

### 8. Package Individual Package of PSU

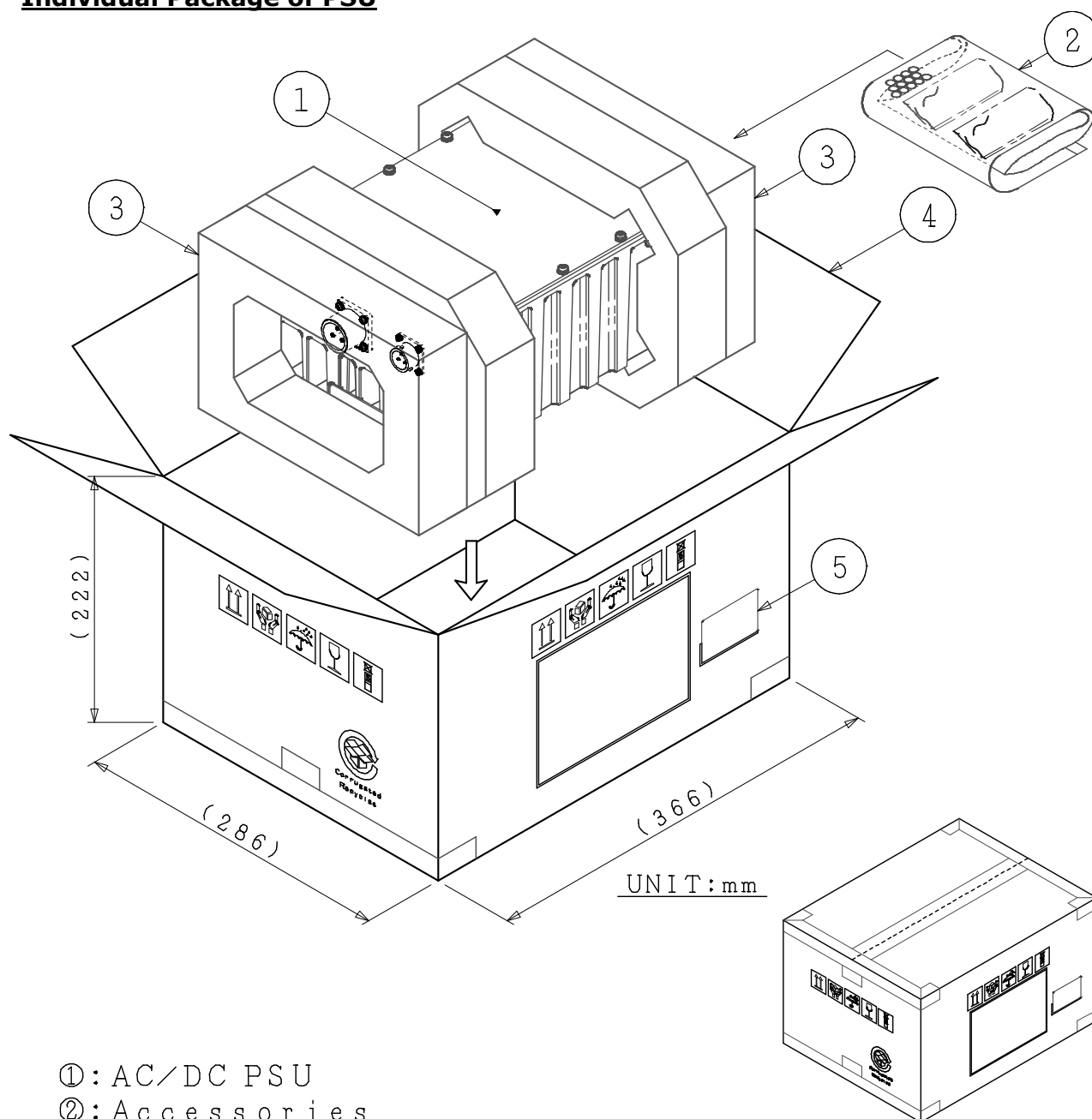

- ①: AC/DC PSU
- ②: Accessories
  - AC mating connector  
GTS06CF16-10S(025)
  - MS mating connector  
PT06E-12-3S(470)
- ③: Polyethylene foam for package cushioning
- ④: Double-faced corrugated fiberboard
- ⑤: Label

\* Above Specifications are subject to change without notice.

## AC Power Operating Option

### Shipment Package (BUC and PSU)

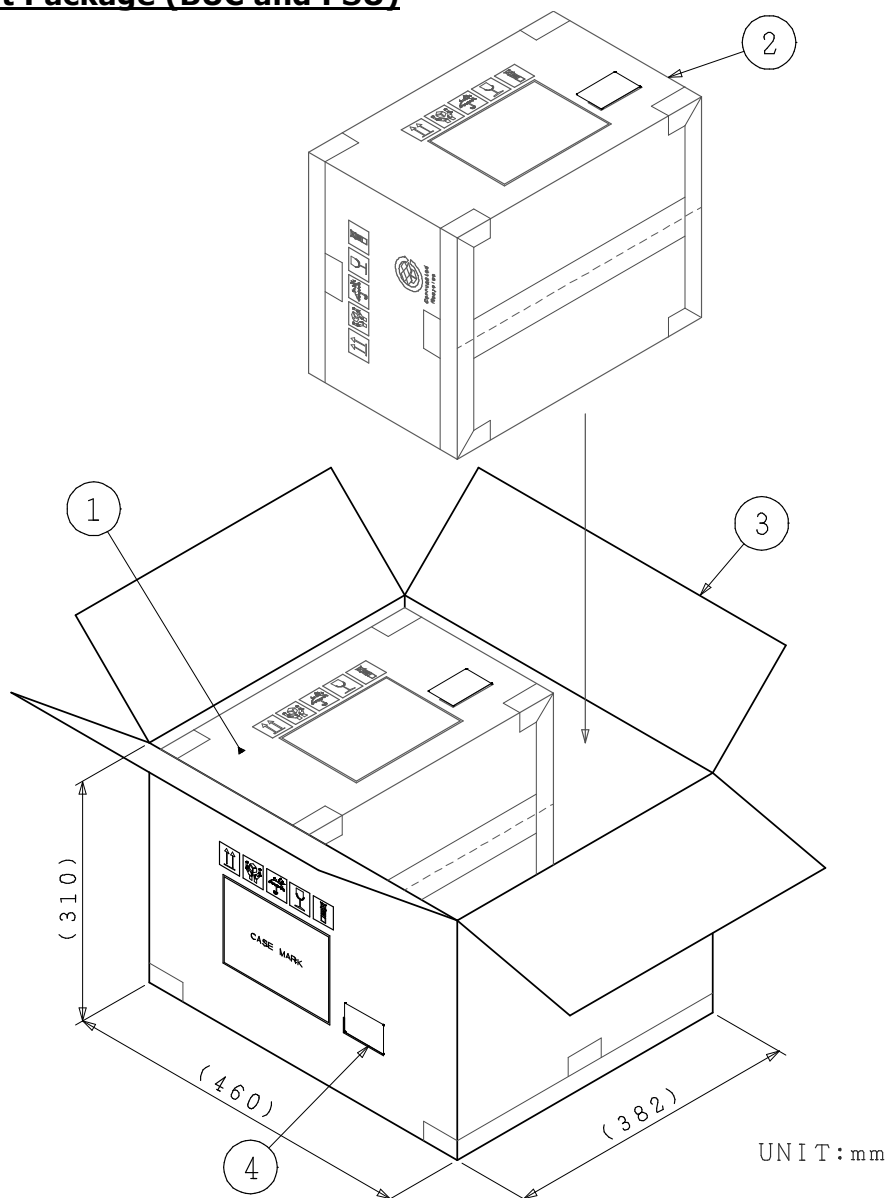

Pictorial Marking for Handling of Goods



THIS WAY UP



FRAGILE



KEEP DRY



HANDLE WITH CARE



LAYERS LIMIT: 3



CORRUGATED RECYCLES

Corrugated Recycles

①: BUC (NJ T 8 3 7 1 \* )

②: AC / DC PSU (NJ Z 1 2 9 5 )

③: Double-wall corrugated fiberboard

④: Label

\* Above Specifications are subject to change without notice.

## AC Power Operating Option

### 9. Install Instructions

#### Direction and Space

- a) Horizontal direction  
Cooling fan side shall be set to upward direction

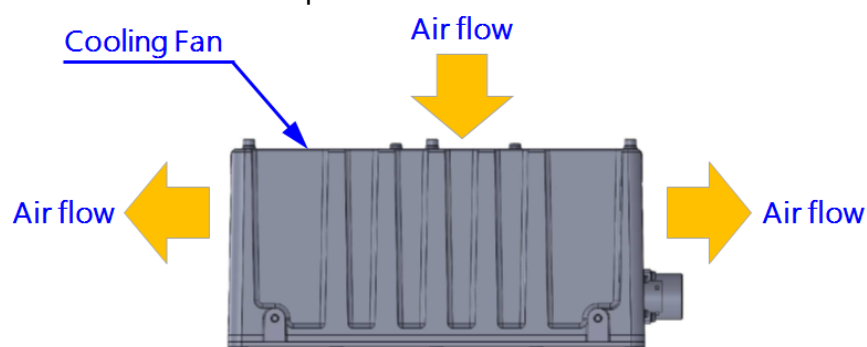

- b) Vertical direction  
Connector side shall be set to downward direction

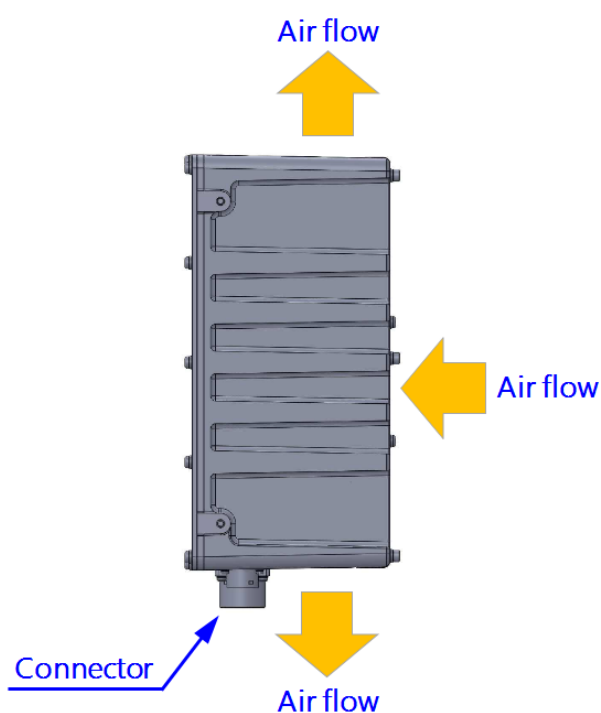

- c) Space  
More than 30mm of space at least from inlet/outlet of cooling fan must be reserved.

\* Above Specifications are subject to change without notice.

## AC Power Operating Option

### 10. Connection Overview between Ku 40W BUC and 500W AC/DC PSU

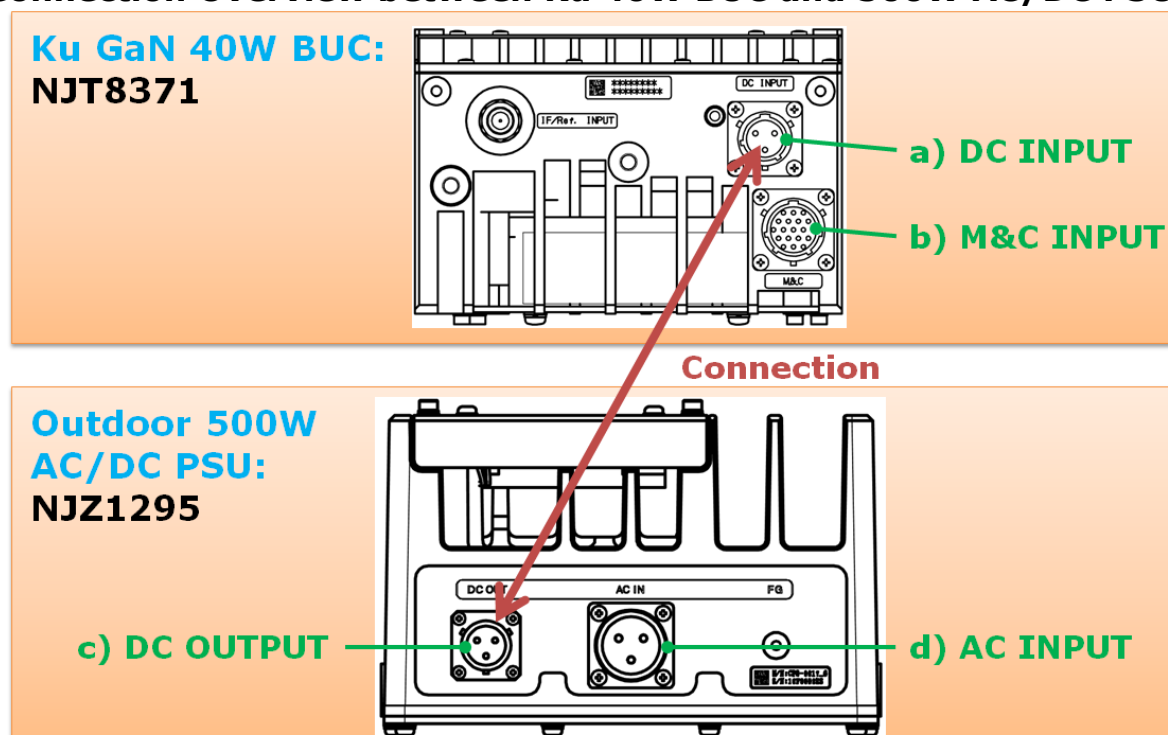

#### a) DC INPUT at NJT8371 (Ku GaN 40W BUC)

- Product connector: PT02E-12-3P(025) [ Amphenol / 3 pins, male ]
  - Mating connector: PT06E-12-3S(470) [ Amphenol / 3 sockets, female ]
- \* Mating connector is enclosed in the shipping package of NJT8371*

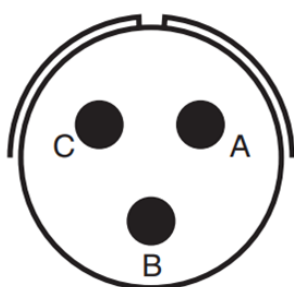

Pin No.	Item	Description
A	DC Input (+)	Prime: +36 to +60 V / DC Voltage
B	Frame GND	GND
C	DC Input (-)	Return

\* Above Specifications are subject to change without notice.



## AC Power Operating Option

### b) M&C INPUT at NJT8371 (Ku GaN 40W BUC)

- Product connector: PT02E-14-19P(025) [ Amphenol / 19 pins, male ]
  - Mating connector: PT06E-14-19S(470) [ Amphenol / 19 sockets, female ]
- \* Mating connector is enclosed in the shipping package of NJT8371*

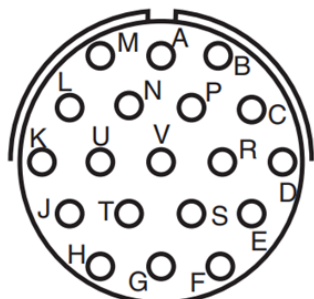

Pin No.	Item	Description
A	GND	GND
B	GND	GND
C	N.C.	-
D	N.C.	-
E	N.C.	-
F	RS-232C GND	Available to use with RS-232C M&C option
G	RS-232C RxD	Available to use with RS-232C M&C option
H	RS-232C TxD	Available to use with RS-232C M&C option
J	N.C.	-
K	N.C.	-
L	N.C.	-
M	N.C.	-
N	N.C.	-
P	N.C.	-
R	N.C.	-
S	N.C.	-
T	N.C.	-
U	N.C.	-
V	N.C.	-

### c) DC OUTPUT at NJZ1295 (500W AC/DC PSU)

- Product connector: PT02E-12-3P(025) [ Amphenol / 3 pins, male ]
  - Mating connector: PT06E-12-3S(470) [ Amphenol / 3 sockets, female ]
- \* Mating connector is enclosed in the shipping package of NJZ1295*

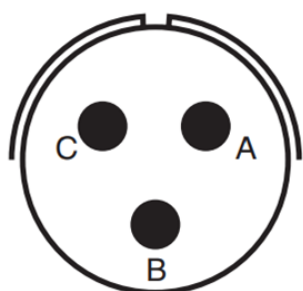

Pin No.	Item	Description
A	DC Input (+)	Prime: +36 to +60 V / DC Voltage
B	Frame GND	GND
C	DC Input (-)	Return

\* Above Specifications are subject to change without notice.

## AC Power Operating Option

### d) AC INPUT at NJZ1289 (500W AC/DC PSU)

- Product connector: GTS030-16-10P(025) [ Amphenol / 3 pins, male ]
  - Mating connector: GTS06CF-16-10S(025) [ Amphenol / 3 sockets, female ]
- \* Mating connector is enclosed in the shipping package of NJZ1289*

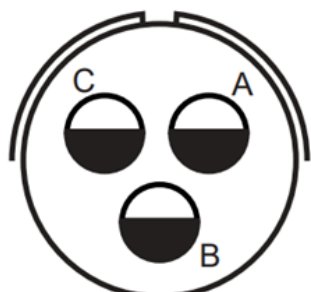

Pin No.	Item	Description
A	AC Input (Live)	100 to 240 V, AC Voltage
B	Frame GND	GND
C	AC Input (Neutral)	100 to 240 V, AC Voltage

### Cable Option

#### ● Model No. NJZ1290A03

Cable between NJZ1295 (500W AC/DC PSU) and AC Outlet

Weatherized Cable / Length: 3m / AC Mating Connector assembled  
/ No assembly in AC Outlet Side

Mating Connector of "d) AC INPUT (NJZ1295)"

*P/N: GTS06CF16-10S(025)*

No assembly for AC Outlet

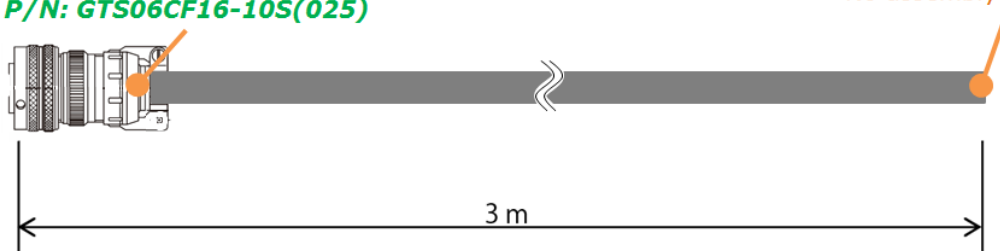

#### ● Model No. NJZ1290A04

Connection Cable between NJT8371 (Ku GaN 40W BUC) and NJZ1285 (500W AC/DC PSU)

Weatherized Cable / Length: 5m / Two Mating Connectors assembled

Mating Connector of "a) DC INPUT (NJT8371)"

*P/N: PT06W-12-3S(025)*

Mating Connector of "c) DC OUTPUT (NJZ1295)"

*P/N: PT06W-12-3S(025)*

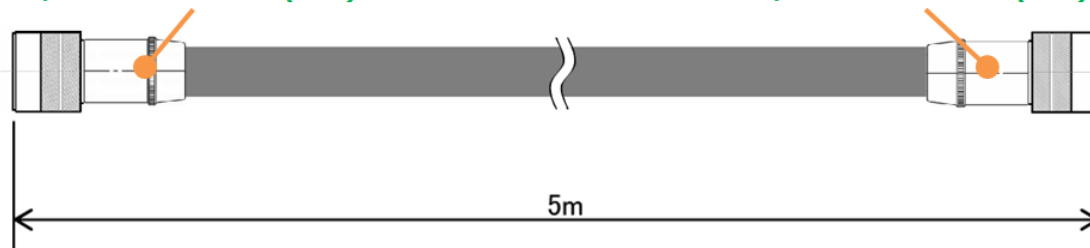

\* Above Specifications are subject to change without notice.

## Mounting Bracket Option

### 1. $\Phi 76$ Mast Mount Bracket of NJT8371 (Ku GaN 40W BUC)

- Model No. NJZ1290D05

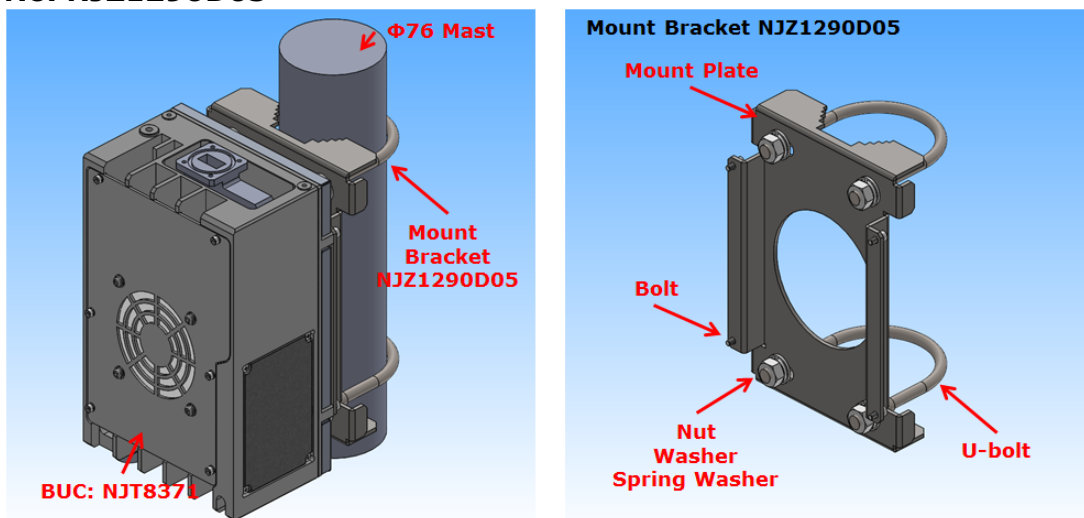

Item	Qty	Description
Mount Plate	1	SUS
Bolt	4	SUS, M4, with W & SW, for fixing BUC
U-bolt	2	SUS, 65A(2-1/2"), M10
Nut	4	SUS, M10
Washer	4	SUS, for M10
Spring Washer	4	SUS, for M10

### 2. $\Phi 76$ Mast Mount Bracket of NJZ1295 (500W AC/DC PSU)

- Model No. NJZ1290D04

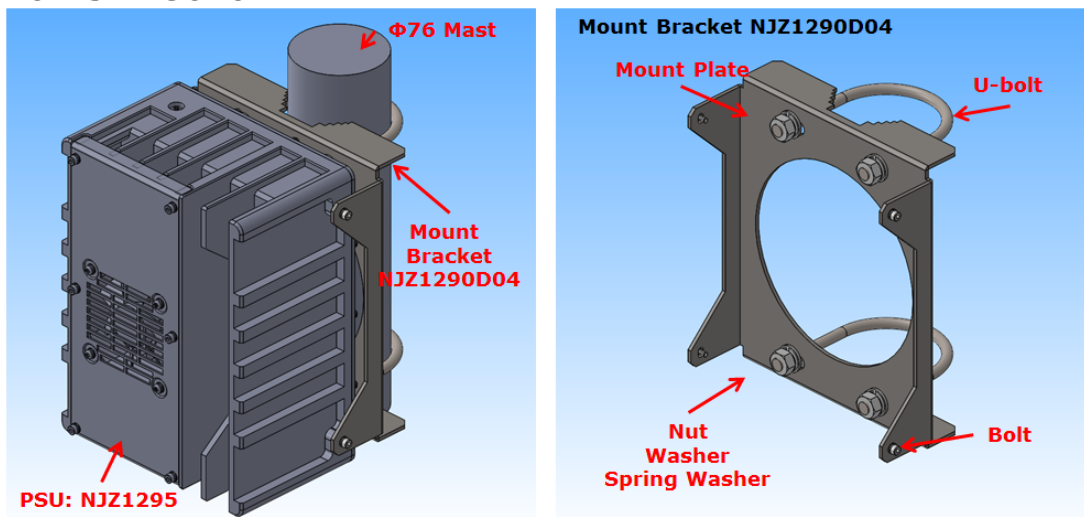

Item	Qty	Description
Mount Plate	1	SUS
Bolt	4	SUS, M4, with W & SW, for fixing BUC
U-bolt	2	SUS, 65A(2-1/2"), M10
Nut	4	SUS, M10
Washer	4	SUS, for M10
Spring Washer	4	SUS, for M10

\* Above Specifications are subject to change without notice.