

**Improved  
Specifications**

# Genesys™

**GENH Series  
Programmable DC Power Supplies  
750W in 1U Half-Rack Size  
Built in RS-232 & RS-485 Interface  
Advanced Parallel Operation**

**Optional Interface:  
LXI Compliant LAN  
IEEE488.2 SCPI (GPIB) Multi-drop  
Isolated Analog Programming**



**Genesys™ Family**

**GenH 750W Half Rack**

**Gen1U 750/1500W Full Rack**

**Gen2U 3.3/5kW**

## TDK-Lambda

## Genesys™ GENH750W-1U

The Genesys™ family of programmable power supplies sets a new standard for flexible, reliable, AC/DC power systems in OEM, Industrial and Laboratory applications.

### Features include:

- High Power Density available: 750W in 1U half-rack size.
- Wide Range Input (85 - 265Vac Continuous)
- Active Power Factor Correction (0.99 typical)
- Output Voltage up to 600V, Current up to 100A
- Built-in RS-232/RS-485 Interface
- Front Panel Lockout
- Last-Setting Memory
- High Resolution 16 bit ADCs & DACs
- Reliable Encoders for Voltage and Current Adjustment
- Constant Voltage/Constant Current auto-crossover
- Advanced Parallel reports total current up to four identical units
- Global Commands for Serial RS-232/RS-485 Interface
- Independent Remote ON/OFF and Remote Enable/Disable
- External Analog Programming and Monitoring
- Reliable Modular and SMT Design
- 19" Rack Mounted ATE benchtop and OEM applications
- Side-by-side mounting of two units in a 19" rack
- Optional Interfaces
  - Isolated Analog Programming and Monitoring Interface (0-5V/0-10V & 4-20mA)
  - IEEE 488.2 SCPI (GPIB) Multi-Drop
  - LXI** Compliant LAN
- LabView® and LabWindows® drivers
- Five Year Warranty



Worldwide Safety Agency Approvals; CE Mark for LVD and EMC Regulation

### Front Panel Description

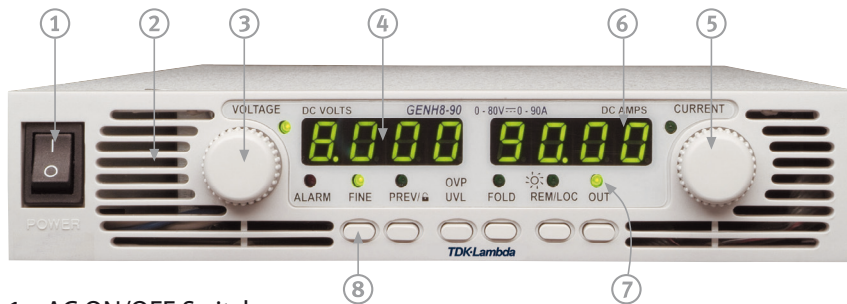

1. AC ON/OFF Switch
2. Air Intake allows zero stacking for maximum system flexibility and power density.
3. Reliable encoder controls Output Voltage and sets Address.
4. Volt Display shows Output Voltage and directly displays OVP, UVL and Address settings.
5. Reliable encoder controls Output Current, sets baudrate and Advanced Parallel mode.
6. Current Display shows Output Current and displays baudrate.
7. Function/Status LEDs:
  - Alarm
  - Fine Control
  - Preview Settings
  - Foldback Mode
  - Remote Mode
  - Output On
8. Pushbuttons allow flexible user configuration
  - Coarse and Fine adjustment of Output Voltage/Current and Advanced Parallel Master or Slave
  - Preview settings and set Voltage/Current with Output OFF, Front Panel Lockout
  - Set OVP and UVL Limits
  - Set Current Foldback
  - Local/Remote Mode and select Address and Baudrate
  - Output ON/OFF and Auto-Start/Safe-Start Mode

## Applications

Genesys™ power supplies are designed for demanding applications. Common controls are shared across all platforms

### Test and Measurement

Last-Setting memory simplifies test design and requires no battery backup.

Built-in RS-232/RS-485 gives maximum system flexibility along with 0-5V and 0-10V, selectable analog programming.

Wide range of available inputs allows testing of many different devices.

### Semiconductor Processing and Burn-in

Safe-Start may be ENABLED to re-start at Output OFF to protect load.

Wide range input (85-265Vac) with Active Power Factor correction rides through input transients easily.

### Component Test

High power density, zero stacking and single wire parallel operation give maximum system flexibility.

### Laser Diode

OVP is directly set on Voltage Display, assuring accurate protection settings.

Current Limit Fold Back assures load is protected from current surges.

### Heater Supplies

Smooth, reliable encoders enhance front panel control. Remote analog programming is user selectable 0-5V or 0-10V.

### RF Amplifiers and Magnets

Robust design assures stable operation under a wide variety of loads.

High linearity in voltage and current mode.

## Rear Panel Description

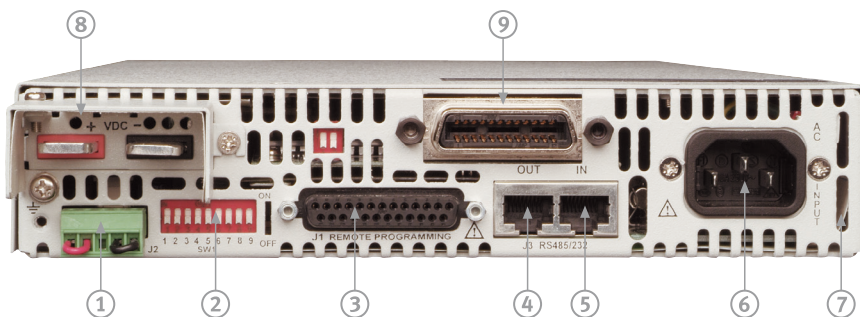

1. Remote/Local Output Voltage Sense Connections.
2. DIP Switches select 0-5V or 0-10V Programming and other functions.
3. DB25 (Female) connector allows (Non-isolated) Analog Program and Monitor and other functions.
4. RS-485 OUT to other Genesys™ Power Supplies.
5. RS-232/RS-485 IN Remote Serial Programming.
6. Wide-Range Input 85-265VAC continuous, 47/63Hz with Active Power Factor Correction (0.99 typical) AC Input Connector: IEC320.
7. Exit air assures reliable operation when zero stacked.
8. Output Connections: Rugged busbars for 6V up to 60V Output; Connector for Outputs >60V.
9. Optional Interface Position for IEEE 488.2 SCPI (shown) or Isolated Analog Interface or LAN Interface.

Specifications in Blue are improved

1.0 MODEL	GENH	6-100	8-90	12.5-60	20-38	30-25	40-19	60-12.5	80-9.5	100-7.5	150-5	300-2.5	600-1.3
1. Rated output voltage (*1)	V	6	8	12.5	20	30	40	60	80	100	150	300	600
2. Rated Output Current (*2)	A	100	90	60	38	25	19	12.5	9.5	7.5	5	2.5	1.3
3. Rated Output Power	W	600	720	750	760	750	760	750	760	750	750	750	780
4. Efficiency at 100/200Vac (*3)	%	76/78	77/80	81/84	82/85	82/85	83/87	83/87	83/87	83/87	83/87	83/87	83/87

**1.1 CONSTANT VOLTAGE MODE**

1. Max. line regulation (0.01% of Vo+ 2mV)(*4)	mV	2.6	2.8	3.3	4	5	6	8	10	12	17	32	62		
2. Max load regulation (0.01% of Vo+2mV)(*5)	mV	2.6	2.8	3.3	4	5	6	8	10	12	17	32	62		
3. Ripple and noise p-p 20MHz (*9)	mV	60	50	60	60	50	60	60	75	75	75	130	300		
4. Ripple r.m.s 5Hz~1MHz (*9)	mV	8	6	7	7.5	6	7	7	7	8	8	20	60		
5. Remote sense compensation/line	V	1	1	1	1	1.5	2	3	4	5	5	5	5		
6. Temp. coefficient	PPM/°C	50PPM/°C of rated output voltage, following 30 minutes warm up													
7. Temp. stability	%	0.01% of rated Vout over 8hrs interval following 30 minutes warm-up. Constant line, load & temp.													
8. Up-prog. response time, 0~Vo Rated	mS	80mS, N.L./F.L, resistive load										150mS, N.L./F.L, resistive load		250	
9. Down-prog response time full-load	mS	10										80		150	250
10. Down-prog response time No-load	mS	500	600	700	800	900	1000	1100	1200	1500	2000	2500	4000		
11. Transient response time (*8)	mS	Less than 1mSec for models up to and including 100V, 2mSec for models above 100V													
12. Temp. drift	%	0.01% of rated Vout over 8hrs interval following 30 minutes warm up. Constant line, load & temp.													

**1.2 CONSTANT CURRENT MODE**

1. Max. line regulation (0.01% of Io+ 2mA)(*4)	mA	12	11	8.0	5.8	4.5	3.9	3.25	2.95	2.75	2.5	2.25	2.13
2. Max. load regulation (0.02% of Io+5mA)(*6)	mA	25	23	17	12.6	10	8.8	7.5	6.9	6.5	6.0	5.5	5.26
3. Ripple r.m.s 5Hz~1MHz. (*7)	mA	190	160	110	50	45	30	15	10	10	8	6	4
4. Temp. coefficient	PPM/°C	70PPM/°C from rated output voltage, following 30 minutes warm up											
5. Temp. stability	%	0.01% of rated Iout over 8hrs interval following 30 minutes warm up. Constant line, load & temp.											
6. Warm up drift	%	Less than 0.1% rated output current over 30 min following power on or output voltage / current change											

**1.3 PROTECTIVE FUNCTIONS**

1. OCP	0~105% Constant Current
2. OCP Foldback	Output shut down when power supply change from CV to CC. User selectable.
3. OVP type	Inverter shut-down, manual reset by AC input recycle or by OUT button or by communication port
4. OVP trip point	0.5~7.5V   0.5~10V   1~15V   1~24V   2~36V   2~44V   5~66V   5~88V   5~110V   5~165V   5~330V   5~660V
5. Over Temp Protection	User selectable, latched or non latched

**1.4 ANALOG PROGRAMMING AND MONITORING**

1. Vout Voltage Programming	0~100%, 0~5V or 0~10V, user select. Accuracy and linearity: +/-0.5% of rated Vout.
2. Iout Voltage Programming	0~100%, 0~5V or 0~10V, user select. Accuracy and linearity: +/-1% of rated Iout.
3. Vout Resistor Programming	0~100%, 0~5/10Kohm full scale, user select. Accuracy and linearity: +/-1% of rated Vout.
4. Iout Resistor Programming	0~100%, 0~5/10Kohm full scale, user select. Accuracy and linearity: +/-1.5% of rated Iout.
5. On/Off control (rear panel)	By electrical. Voltage: 0~0.6V/2~15V, or dry contact, user selectable logic
6. Output Current monitor	0~5V or 0~10V, accuracy: 1%, user selectable
7. Output Voltage monitor	0~5V or 0~10V, accuracy: 1%, user selectable
8. Power Supply OK signal	TTL high (4~5V) -OK, 0V-Fail 500ohm series resistance
9. CV/CC indicator	Open collector, CC mode: On, CV mode: Off, Maximum voltage: 30V, maximum sink current: 10mA
10. Enable/Disable	Dry contact. Open: off, Short: on. Max. voltage at Enable/Disable in: 6V
11. Local/Remote analog control	By electrical signal or Open/Short: 0~0.6V or short: Remote, 2~15V or open: Local.
12. Local/Remote analog control indicator	Open collector, Local: Open, Remote: On. Maximum voltage: 30V, maximum sink current: 5mA.

**1.5 FRONT PANEL**

1. Control functions	Vout/Iout manual adjust by separate encoders (coarse and fine adjustment selectable) OVP/UVL manual adjust by Volt. Adjust encoder AC on/off, Output on/off, Re-start modes (auto, safe), Foldback control (CV to CC), Go to local control Address selection by Voltage (or current) adjust encoder. Number of addresses: 31 RS232/485 and IEEE488.2 selection by IEEE enable switch and DIP switch Baudrate selection: 1200, 2400, 4800, 9600 and 19,200
2. Display	Voltage 4 digits, accuracy: 0.05%+/-1 count Current 4 digits, accuracy: 0.2%+/-1 count
3. Indications	Voltage, Current, Alarm, Fine, Preview, Foldback, Local, Output On, Front Panel Lock

**1.6 Interface RS-232&RS-485 or Optional GPIB / LAN Interface**

Model	V	6	8	12.5	20	30	40	60	80	100	150	300	600
-------	---	---	---	------	----	----	----	----	----	-----	-----	-----	-----

**1. Remote Voltage Programming (16 bit)**

Resolution (0.02% of Vo Rated)	mV	0.12	0.16	0.25	0.4	0.6	0.8	1.2	1.6	2.0	3.0	6.0	12.0
Accuracy (0.05%Vo Rated Output voltage) (*11)	mV	3.0	4.0	6.3	10	15	20	30	40	50	75	150	300

**2. Remote Current Programming (16 bit)**

Resolution (0.002% of Io Rated)	mA	2.00	1.80	1.20	0.76	0.50	0.38	0.25	0.19	0.15	0.10	0.05	0.03
Accuracy (0.1% of Io Rated+0.1% of Io Actual Output)(*10)	mA	200	180	120	76	50	38	25	19	15	10	5.0	2.6

**3. Readback Voltage**

Resolution of Vo Rated	mV	0.12	0.16	1.125	1.20	1.20	1.2	1.2	1.60	11.0	10.50	12	12
Accuracy 0.05% Vo Rated	mV	3	4	6.3	10	15	20	30	40	50	75	150	300

**4. Readback Current**

Resolution of Io Rated	mA	11	1.80	1.20	1.14	1.25	1.14	1.13	0.19	0.15	0.15	0.13	0.12
Accuracy 0.3% of Io Rated(*10)	mA	300	270	180	114	75	57	37.50	28.50	22.50	15	7.50	3.90

**5. OVP/UVL Programming**

Resolution (0.1% of Vo Rated)	mV	6	8	12	20	30	40	60	80	100	150	300	600
Accuracy (1% of Vo Rated)	mV	60	80	125	200	300	400	600	800	1000	1500	3000	6000

\*1: Minimum voltage is guaranteed to maximum 0.2% of Vo Rated.

\*2: Minimum current is guaranteed to maximum 0.4% of Io Rated.

\*3: At maximum output power.

\*4: 85~132Vac or 170~265Vac, constant load.

\*5: From No-load to Full-load, constant input voltage.

\*6: For load voltage change, equal to the unit voltage rating, constant input voltage.

\*7: For 6V models the ripple is measured at 2~6V output voltage and full output current.

For other models, the ripple is measured at 10~100% output voltage and full output current.

\*8: Time for the output voltage to recover within 0.5% of its rated for a load change 10~90% of rated output, Output set-point: 10~100%.

\*9: For 6V~300V models: measured with JEITA RC-9131A 1:1 probe. For 600V model: measured with 10:1 probe Accuracy -Values have been calculated at Vo Rated & Io Rated.

\*10: The Constant Current programming readback and monitoring accuracy does not include the warm-up and Load regulation thermal drift.

\*11: Measured at the sense point.

## General Specifications Genesys™ GENH750W

<b>2.1 INPUT CHARACTERISTICS</b>	
1. Input voltage/freq. (*1)	85~265Vac continuous, 47~63Hz, single phase
2. Power Factor	0.99 @100/200Vac, rated output power.
3. EN61000-3-2,3 compliance	Complies with EN61000-3-2 class A and EN61000-3-3 at 20~100% output power.
4. Input current 100/200Vac	750W :10.5A / 5A,
5. Inrush current 100/200Vac	750W :Less than 25A,
6. Hold-up time	More than 20mS, 100Vac, at 100% load.
<b>2.2 POWER SUPPLY CONFIGURATION</b>	
1. Parallel Operation	Up to 4 units in master/slave mode with single wire current balance connection
2. Series Operation	Up to 2 units. with external diodes. 600V Max to Chassis ground
<b>2.3 ENVIRONMENTAL CONDITIONS</b>	
1. Operating temp	0~50°C, 100% load.
2. Storage temp	-20~70°C
3. Operating humidity	30~90% RH (non-condensing).
4. Storage humidity	10~95% RH (non-condensing).
5. Vibration	MIL-810E, method 514.4, test cond. I-3.3.1. The EUT is fixed to the vibrating surface.
6. Shock	Less than 20G, half sine, 11mSec. Unit is unpacked.
7. Altitude	Operating: 10000ft (3000m), Derat output current by 2%/100m above 2000m, Non operating: 40000ft (12000m).
<b>2.4 EMC</b>	
1. Applicable Standards:	
2. ESD	IEC1000-4-2. Air-disch. -8KV, contact disch. -4KV
3. Fast transients	IEC1000-4-4. 2KV
4. Surge immunity	IEC1000-4-5. 1KV line to line, 2KV line to ground
5. Conducted immunity	IEC1000-4-6. 3V
6. Radiated immunity	IEC1000-4-3. 3V/m
7. Conducted emission	EN55022B, FCC part 15J-B, VCCI-B.
8. Radiated emission	EN55022A, FCC part 15-A, VCCI-A.
9. Voltage dips	EN61000-4-11
10. Conducted emission	EN55022B, FCC part 15-B, VCCI-B.
11. Radiated emission	EN55022A, FCC part 15-A, VCCI-A.
<b>2.5 SAFETY</b>	
1. Applicable standards:	UL 60950-1, CSA22.2 No.60950-1, IEC 60950-1, EN 60950-1
2. Interface classification	Models with Vout 50V: Output is SELV, all communication/control interfaces (RS232/485, IEEE, Isolated Analog, LAN, Sense, Remote Programming and Monitoring) are SELV. Models with 60V Vout 400V: Output is Hazardous, communication/control interfaces: RS232/485, IEEE, Isolated Analog, LAN, Remote Programming and Monitoring (pins 1-3, pins14-16) are SELV, Sense, Remote Programming and Monitoring (pins 8-13, pins 21-25) are Hazardous. Models with 400V Vout 600V: Output is Hazardous, all communication/control interfaces (RS232/485, IEEE, Isolated Analog, LAN, Sense, Remote Programming and Monitoring) are Hazardous.
3. Withstand voltage	Vout 50V models : Input-Output (SELV): 4242VDC 1min, Input-communication/control (SELV): 4242VDC 1min, Input-Ground: 2828VDC 1min. 60V Vout 150V models: Input-Output (Hazardous): 3425VDC 1min, Input-communication/control (SELV): 4242VDC 1min, Output(Hazardous)-SELV: 2307VDC 1min, Output(Hazardous)-Ground: 1414VDC 1min, Input-Ground: 2828VDC 1min. 300V Vout 600V models: Input-Output(Hazardous): 3490VDC 1min, Input-communication/control (SELV): 4242VDC 1min, Hazardous. Output-communication/control(SELV): 4242VDC 1min, Output(Hazardous)-Ground: 2738VDC 1min, Input-Ground: 2828VDC 1min.
4. Insulation resistance	More than 100Mohm at 25°C, 70% RH.
<b>2.6 MECHANICAL CONSTRUCTION</b>	
1. Cooling	Forced air flow: from front to rear. No ventilation holes at the top or bottom of the chassis; Variable fan speed.
2. Dimensions (WxHxD)	W: 214.0mm, H: 43.6mm, (57.0mm Benchtop version), D: 437.5mm (excluding connectors, encoders, handles, etc.)
3. Weight	7Kg (15 Lbs)
4. AC Input connector	IEC320 AC Inlet.
5. Output connectors	6V to 60V models: Bus-bars (hole Ø 6.5mm). 80V to 600V models: Meating plug, Phoenix P/N: GIC 2.5/4-ST-7.62.
<b>2.7 RELIABILITY SPECS</b>	
1. Warranty	5 years.

Also available, Genesys™

1U full Rack 750W/1500W/2400W

2U full Rack 3300W/5000W



**Genesys™ Power Benchtop Parallel and Series Configurations**

**Parallel operation - Master/Slave:**

Active current sharing allows up to four identical units to be connected in an auto-parallel configuration for four times the output power.

In Advanced Parallel Master/Slave Mode, total current is programmed and reported by the Master, Up to four supplies act as one.



**Series operation**

Up to two units may be connected in series to increase the output voltage or to provide bipolar output. (Max 600V to Chassis Ground).



**Remote Programming via RS-232 & RS-485 Interface**

Standard Serial Interface allows chain control of up to 31 power supplies on the same bus with built-in RS-232 & RS-485 Interface.



**Programming Options (Factory installed)**

**Digital Programming via IEEE Multi-Drop Interface**

**P/N: IEEE**

- Allows IEEE Master to control up to 30 slaves over RS-485 daisy-chain
- Only the Master needs be equipped with IEEE Interface
- IEEE 488.2 SCPI Compliant
- Program Voltage
- Measure Voltage
- Over Voltage setting and shutdown
- Error and Status Messages
- Program Current
- Measure Current
- Current Foldback shutdown

**Isolated Analog Programming**

Four Channels to Program and Monitor Voltage and Current. Isolation allows operation with floating references in harsh electrical environments.

Choose between programming with Voltage or Current.

Connection via removable terminal block: Phoenix MC1,5/8-ST-3.81.

- Voltage Programming, user-selectable 0-5V or 0-10V signal. **P/N: IS510**  
 Power supply Voltage and Current Programming Accuracy ±1%  
 Power supply Voltage and Current Monitoring Accuracy ±1.5%
- Current Programming with 4-20mA signal. **P/N: IS420**  
 Power supply Voltage and Current Programming Accuracy ±1%  
 Power supply Voltage and Current Monitoring Accuracy ±1.5%

**LAN Interface**

**LXI Compliant to Class C**

**P/N: LAN**

- Meets all LXI-C Requirements
- Address Viewable on Front Panel
- Fixed and Dynamic Addressing
- Compatible with most standard Networks
- VISA & SCPI Compatible
- LAN Fault Indicators
- Auto-detects LAN Cross-over Cable
- Fast Startup

## Accessories

### Rack Mounting applications P/N:GENH/RM

The Rack Mounted kit allows the units to be zero stacking for maximum system flexibility and power density without increasing the 1U height of the units To install one GENH750W unit or two units side-by-side in a standard 19" rack in 1U(1.75") height, use option kit P/N:GENH/RM

#### Single unit installation

Single GENH750W power supply in a standard 19" rack in 1U(1.75") height,



#### Dual unit installation

Two GENH750W power supplies side-by-side in a standard 19" rack in 1U (1.75") height,



### Benchtop applications P/N:GENH/MO

The benchtop stacking kit allows the units to be Zero stacked for maximum system flexibility and power density without increasing the 1U height of the units. To install a GENH750W two units or three units one on top of the other use option kit P/N:GENH/MO



### Communication cable

RS-232/RS-485 Cable is used to connect the power supply to the PC Controller.

Mode	RS-485	RS-232	RS-232
PC Connector	DB-9F	DB-9F	DB-25F
Communication Cable	Shield Ground L=2m	Shield Ground L=2m	FShield Ground L=2m
Power Supply Connector	EIA/TIA-568A (RJ-45)	EIA/TIA-568A (RJ-45)	EIA/TIA-568A (RJ-45)
P/N	GEN/485-9	GEN/232-9	GEN/232-25

### Serial link cable\*

Daisy-chain up to 31 Genesys™ power supplies.

Mode	Power Supply Connector	Communication Cable	P/N
RS-485	EIA/TIA-568A (RJ-45)	Shield Ground L=50cm	GEN/RJ45

\* Included with power supply

Outline Drawings Genesys™ GENH 750W

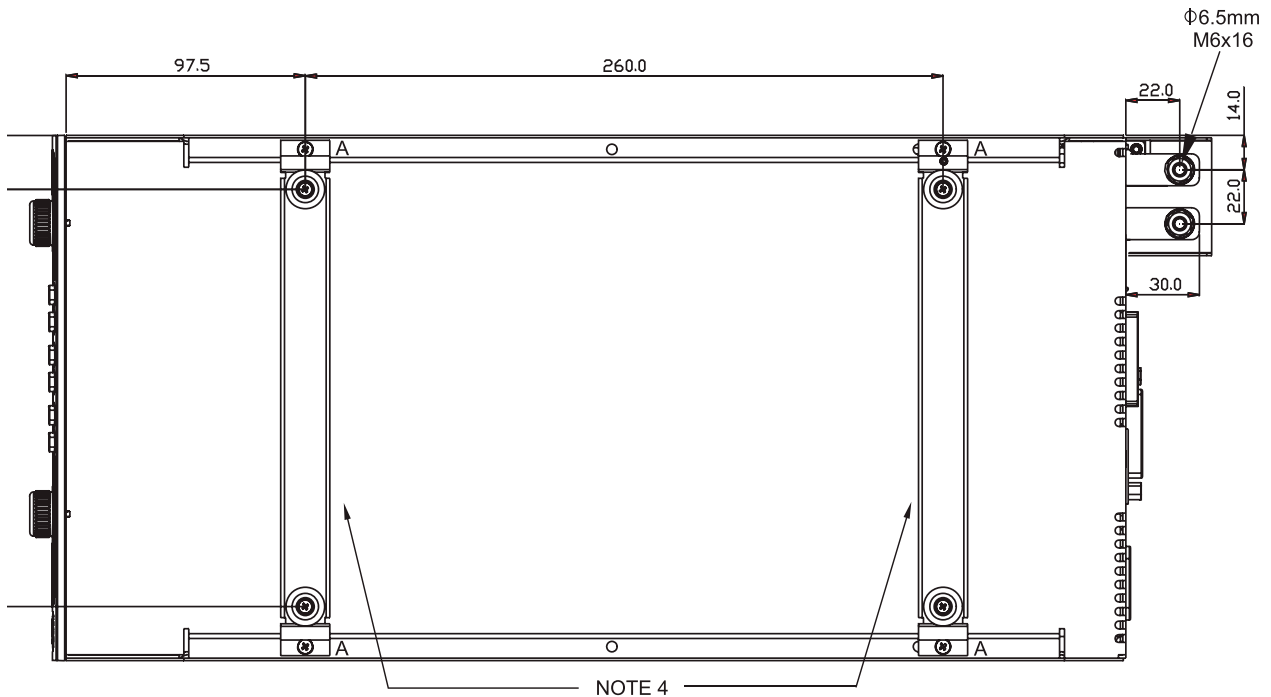
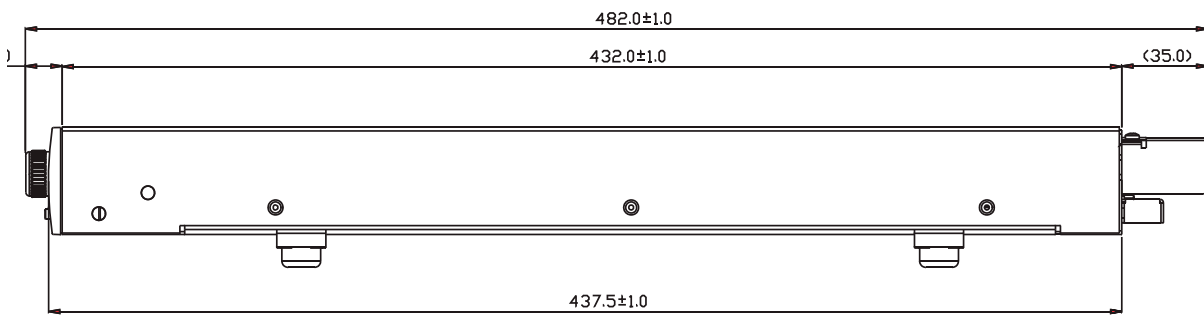
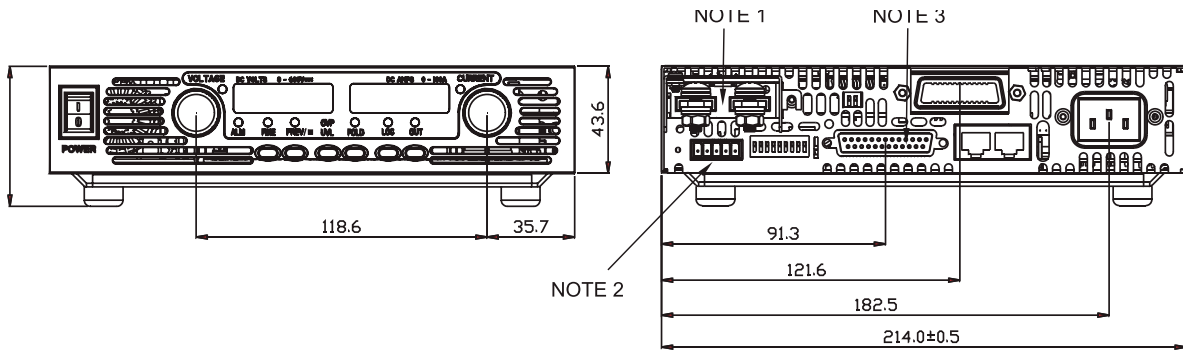

NOTE 1

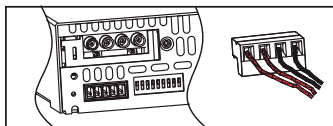

GENH Models 80V to 600V.

NOTES:

1. Bus-bars 6V-60V models  
Connector 80V to 600V model  
Header Phoenix P/N: GIC 2.5/4-G-7.62  
Mating plug Phoenix P/N: GIC 2.5/4-ST-7.62.
2. Mating plug Phoenix P/N: MC 1.5/5-ST-3.81.
3. Mating plug AMP P/N: 745211-2.
4. Benchtop assembly x 2 (removable)  
Screws: 4 x M3x8 marked "A"  
Supplies with the power supply.



Power Supply Identification / Accessories

How to order

<b>GENH</b>	<b>60</b>	<b>- 12.5</b>	<b>-</b>	<b>-</b>
Series Name	Output Voltage (0~60V)	Output Current (0~12.5A)	Factory Options Option: IEEE IS510 IS420 LAN	AC Cable option Region E - Europe GB - United Kingdom J - Japan I - Middle East U - North America

Models GENH750W

Model	Output Voltage VDC	Output Current (A)	Output Power (W)
GENH6-100	0~6V	0~100	600
GENH8-90	0~8V	0~90	720
GENH12.5-60	0~12.5V	0~60	750
GENH20-38	0~20V	0~38	760
GENH30-25	0~30V	0~25	750
GENH40-19	0~40V	0~19	760
GENH60-12.5	0~60V	0~12.5	750
GENH80-9.5	0~80V	0~9.5	760
GENH100-7.5	0~100V	0~7.5	750
GENH150-5	0~150V	0~5	750
GENH300-2.5	0~300V	0~2.5	750
GENH600-1.3	0~600	0~1.3	780

Factory option

RS-232/RS-485 Interface built-in Standard  
 GPIB Interface  
 Voltage Programming Isolated Analog Interface  
 Current Programming Isolated Analog Interface  
 LAN Interface (Complies with **LXI** Class C)

P/N

-  
 IEEE  
 IS510  
 IS420  
 LAN

Region	Europe	United Kingdom	Japan	Middle East	North America
Output Power	750W	750W	750W	750W	750W
AC Cords	10A/250Vac L=2m	10A/250Vac L=2m	13A/125Vac L=2m	10A/250Vac L=2m	13A/125Vac L=2m
Wall Plug	INT'L 7/VII	BS1363	IEC320-C13	SI-32	NEMA 5-15P
Power Supply Connector	IEC320-C13	IEC320-C13		IEC320-C13	IEC320-C13
Part Number	P/N: GEN/E	P/N: GEN/GB	P/N: GEN/J	P/N: GEN/I	P/N : GEN/U

## NORTH AMERICA

TDK-Lambda Americas Inc  
405 Essex Rd. Neptune, NJ 07753  
Tel: +1-732-922-9300 Fax: +1-732-922-1441  
E-mail: sales@us.tdk-lambda.com  
www.us.tdk-lambda.com/hp

## UK

TDK-Lambda UK Ltd.  
Kingsley Avenue Ilfracombe, Devon  
EX 34 8ES United Kingdom  
Tel: +44-1271-856666 Fax: +44-1271-864894  
E-mail: powersolutions@uk.tdk-lambda.com  
www.uk.tdk-lambda.com

## FRANCE

TDK-Lambda France SAS  
ZAC des Delaches  
BP 1077 - Gometz le Chatel  
91940 LES ULIS  
Tel: +33 1 60 12 71 65  
Fax: +33 1 60 12 71 66  
E-mail: france@fr.tdk-lambda.com  
www.fr.tdk-lambda.com

## GERMANY

TDK-Lambda Germany GmbH  
Karl-Bold-Str.40,  
D-77855 Achern, Germany  
Tel: +49-7841-666-0 Fax: +49-7841-500-0  
E-mail: info.germany@de.tdk-lambda.com  
www.de.tdk-lambda.com

## AUSTRIA

TDK-Lambda Austria Sales Office  
Aredstrasse 22,  
A - 2544 Leobersdorf, Austria  
Tel: +43-2256-65584 Fax: +43-2256-64512  
E-mail: info.germany@de.tdk-lambda.com  
www.de.tdk-lambda.com

## ITALY

TDK-Lambda Italy Sales Office  
France Sas Succursale Italiana  
Via dei Lavoratori 128/130  
IT 20092 Cinisello Balsamo, Milano, Italy  
Tel: +39-02-6129-3863 Fax: +39-02-6129-0900  
E-mail: info.italia@it.tdk-lambda.com  
www.it.tdk-lambda.com

## ISRAEL

TDK-Lambda Ltd.  
Sales Office: Kibbutz Givat Hashlosha Tel-Aviv 4880000, Israel  
Tel: +972-3-9024-333 Fax: +972-3-9024-777  
Plant: 56 Haharoshet St.,  
Karmiel Industrial Zone 2165158, Israel  
Tel: +972-4-9887-491 Fax: +972- 4-9583-071  
www.tdk-lambda.co.il E-mail: info@tdk-lambda.co.il

## JAPAN

TDK-Lambda Corporation  
International Sales Division  
Nittetsu Bldg. 6F, 1-13-1 Nihonbashi, Chuo-ku, Tokyo 103-0027, Japan  
Tel: +81-3-5201-7175  
Fax: +81-3-5201-7287  
www.tdk-lambda.com

## CHINA

Shanghai Branch of Wuxi TDK-Lambda Electronic Co. Ltd.  
28F, Xingyuan Technology Building No.418, Guiping Road,  
Shanghai, China 200233  
Tel: +86-21-6485-0777 Fax: +86-21-6485-0666  
www.cn.tdk-lambda.com

Beijing Branch of Wuxi TDK-Lambda Electronic Co. Ltd.  
Room 12B11-12B12, Unit 7 DACHENG SQUARE, No.28  
Xuanwumenxi Street, Xuanwu District Beijing, 100053, CHINA  
Tel: +86-10-6310-4872 Fax: +86-10-6310-4874  
www.cn.tdk-lambda.com

Shenzhen Branch of Wuxi TDK-Lambda Electronics Co.Ltd.  
Room 4302, Excellence Times Square Building,  
4068 Yi Tian Road, Futian District,  
Shenzhen, China 518048  
Tel: +86 -755-83588261 Fax: +86 -755-83588260  
www.cn.tdk-lambda.com

## KOREA

TDK-Lambda Corporation Seoul Office  
8F Songnam Bldg, 1358-6, Seocho-Dong,  
Seocho-Gu, Seoul, 137-862 KOREA  
Tel: +82-2-3473-7051  
Fax: +82-2-3472-9137  
www.tdk-lambda.co.kr

## SINGAPORE

TDK-Lambda Singapore Pte.Ltd.  
Blk 1008 Toa Payoh North # 07-01/03  
Singapore 318996  
Tel: +65-6251-7211 Fax: +65-6250-9171  
www.tdk-lambda.com.sg

## INDIA

TDK-Lambda Bangalore Office  
TDK - LAMBDA Singapore Pte Ltd (India Branch)  
No.989, 1st Cross, 2nd Floor, 13th Main,  
HAL 2nd Stage, Bangalore, Karnataka, India - 560 008  
Tel: +91-80-43550 500  
Fax: +91-80-43550 501  
www.tdk-lambda.com.sg

## MALAYSIA

TDK-Lambda Malaysia Sdn. Bhd.  
c/o TDK (Malaysia) Sdn Bhd  
Lot 709, Nilai Industrial Estate 71800 Nilai  
Negeri Sembilan, Malaysia  
Tel: + 60 6-799 1130  
Fax: + 60 6 799 3277  
www.tdk-lambda.com.my



TDK-Lambda EMEA  
www.emea.tdk-lambda.com