

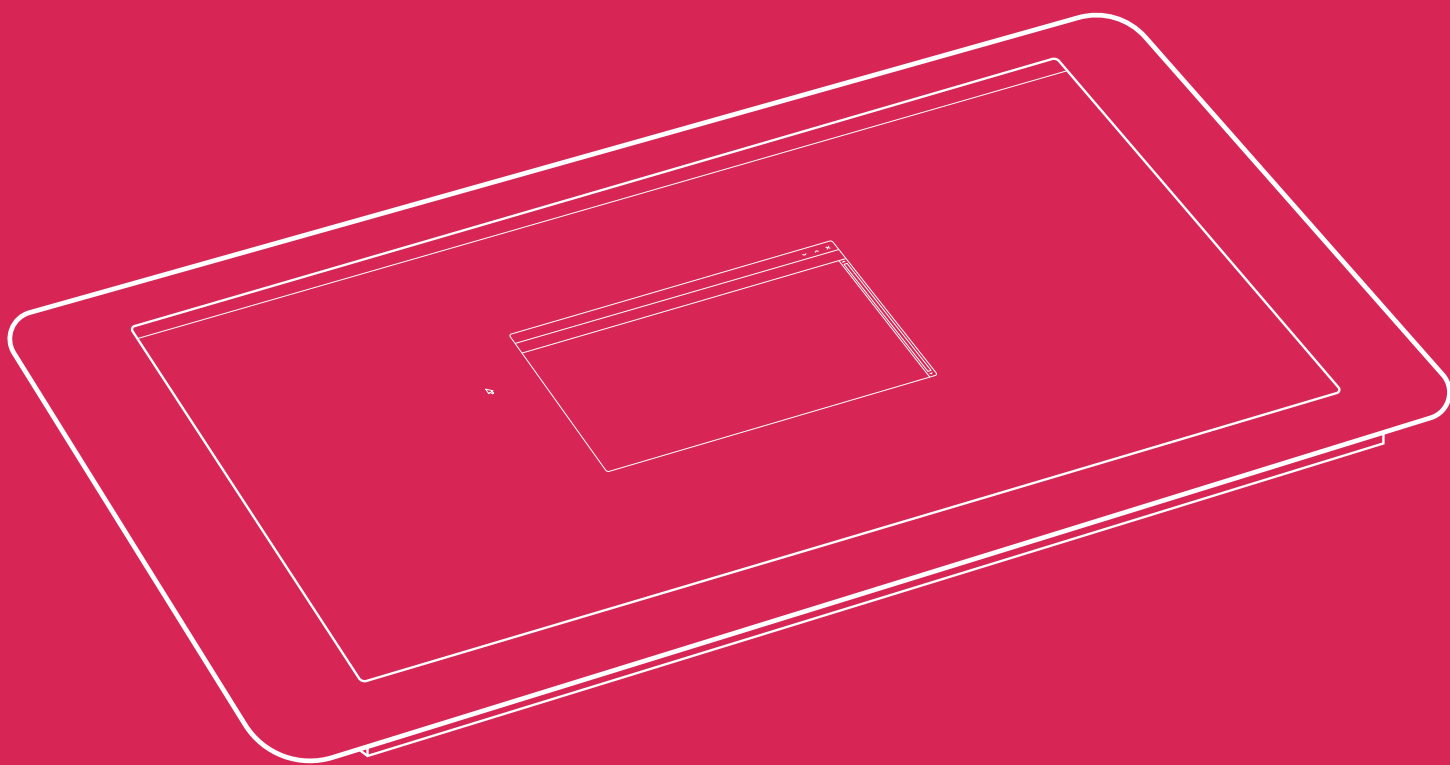

Raspberry Pi Touch Display

Published April 2024



Raspberry Pi Ltd



ES France - Mobilité & Systèmes Embarqués
127 rue de Buzenval BP 26 - 92380 Garches



Tél. 01 47 95 99 80
Fax. 01 47 01 16 22



e-mail : mse@es-france.com
Site Web : www.es-france.com

Overview



This 7" touchscreen display for Raspberry Pi lets you create interactive projects such as tablets, entertainment systems, and information dashboards.

Raspberry Pi OS provides touchscreen drivers with support for ten-finger touch and an on-screen keyboard, giving you full functionality without the need to connect a keyboard or mouse.

The 800 × 480 display connects to Raspberry Pi via an adapter board that handles power and signal conversion. Only two connections to your Raspberry Pi are required: power from the GPIO port, and a ribbon cable that connects to the DSI port on all Raspberry Pi computers except for the Raspberry Pi Zero line.



Specification

Assembly module size:	192.96mm × 110.76mm
Display size (diagonal):	7 inches
Display format:	800 (RGB) × 480 pixels
Active area:	154.08mm × 85.92mm
LCD type:	TFT, normally white, transmissive
Touch panel:	True multi-touch capacitive touch panel with up to 10 points of absolute resolution
Surface treatment:	Anti-glare
Colour configuration:	RGB-stripe
Backlight type:	LED B/L
Production lifetime:	The touch display will remain in production until at least January 2030
Compliance:	For a full list of local and regional product approvals, please visit pip.raspberrypi.com

For our white paper on designing with the Raspberry Pi Touch Display, email applications@raspberrypi.com



SAFETY INSTRUCTIONS

To avoid malfunction or damage to this product, please observe the following:

- **Before connecting the device, shut down your Raspberry Pi computer and disconnect it from external power.**
- If the cable becomes detached, pull the locking mechanism forward on the connector, insert the ribbon cable ensuring the metal contacts face towards the circuit board, then push the locking mechanism back into place.
- This device should be operated in a dry environment at 0–50°C.
- Do not expose it to water or moisture, or place on a conductive surface whilst in operation.
- Do not expose it to excessive heat from any source.
- Care should be taken not to fold or strain the ribbon cable.
- Care should be taken when screwing in parts. A cross-thread can cause irreparable damage and void the warranty.
- Take care whilst handling to avoid mechanical or electrical damage to the printed circuit board and connectors.
- Avoid handling the printed circuit board whilst it is powered and only handle by the edges to minimise the risk of electrostatic discharge damage.
- Store in a cool, dry location.
- Avoid rapid changes of temperature, which can cause moisture to build up in the device.
- The display surface is fragile and has the potential to shatter.
- The product must be mounted in a suitable enclosure. The enclosure, including any gaps provided for ventilation or cable entry, must ensure all parts of the circuit board are inaccessible during operation.

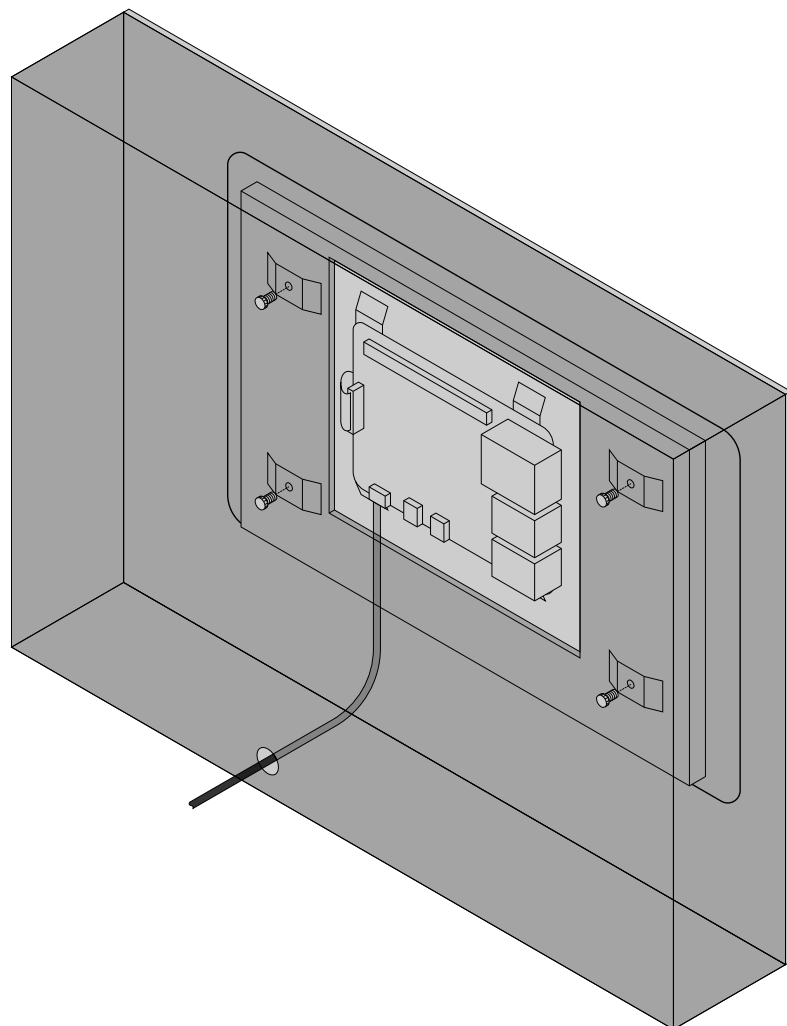



Raspberry Pi is a trademark of Raspberry Pi Ltd



ES France - Mobilité & Systèmes Embarqués
127 rue de Buzenval BP 26 - 92380 Garches



Tél. 01 47 95 99 80
Fax. 01 47 01 16 22



e-mail : mse@es-france.com
Site Web : www.es-france.com