

Introducing the RLS Series

The Industry's Most Flexible,
High Performing, and Intelligent
Regenerative AC & DC
Electronic Load



up to 21kVA in 4U



Regenerative

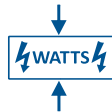

Power
Density

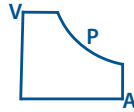

Constant
Power



High
Current

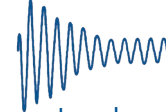

Inrush
Current
Control

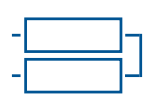

Scalable
Power

Key Features

- Regenerative Electronic Load
 - » 4-Quadrant AC & DC Load
 - » Fully Programmable
- High Power Density – Up to 21kW in 4U; Parallel up to 189kVA/kW per Cabinet, or Multiple Cabinets up to 252kW
- Three-Phase High Power System configurations up to 756kW
- AC, DC
- Single, Split, Three-Phase; Multi-Channel Configurations
 - » Isolated Neutrals independent channel modes
- Input Voltage Range:
350Vac L-N/606Vac L-L or $\pm 500Vdc$
- Wide Load Input Frequency Range 15Hz - 1200Hz
- Galvanic Isolation from Facility AC Input to Load Input and Between Input Phases / Channels
- Dynamic, Quiet and Efficient Operation Using Silicon Carbide (SiC) Based Technology
- High AC Current Capability
- Waveform Capture and Scope Display
- Powerful Current Transient Programming Tools
 - » Generate Harmonics and Interharmonics Currents
 - » Analog I/O Signals Standard
- Intuitive User Interface Using Softkeys & Shuttle
SmartSource Suite: Web Browser Control

RLS Series

Regen 4-Quadrant AC & DC Load up to 756kW

The RLS Regenerative Load Simulator is designed to emulate real-world normal and abnormal load conditions for testing a wide range of AC or DC power generating or conversion equipment. The RLS's high-power density provides 6kVA/kW up to 21kVA/kW in a 4U chassis and can parallel up to 189kVA/kW in a single 19" cabinet. Dual cabinets can parallel up to 252kVA/kW. Three-Phase High Power System configurations available up to 756kW.

The RLS Series is modular by design and scalable in power. Its flexible channel inputs and advanced control and programming capabilities make it ideal for generating complex user-defined current waveforms. Full operator control of current, power and power factor allows for testing a wide range AC or DC power sources.

Application Examples:

- EV Charger Load Testing, On Board Chargers (OBC), Wallboxes, V2G, V2H, V2X, and EV Charging Cables
- Solar PV/Grid-Tied Inverters RLC Loading for Anti-Islanding
- Energy Storage Systems (ESS), Home ESS Load Testing
- UPS Products and PDUs AC Load Testing
- EV Battery Discharge Testing
- Aerospace Power and Converter Testing
- Utility Power Quality and Grid Usage
- Burn-In Testing



Flexible Control

Regenerative Power > 90%

The RGS Regenerative load provides over 90% energy efficiency and significant cost savings. Energy is returned to the facility or the grid rather than converting to heat.

Consider a burn-in test requiring 10 kW for 10 hours. In this simplified example to the right, the use of regenerative loads results in an energy savings of 189 kWh, which significantly reduces both electricity and HVAC costs.

Simplified Example of Regenerative Load Cost Savings

Resistive Load:

- Energy Consumed = 10 kW * 10 hours = 100 kWh
- HVAC Energy (Assuming 1:1 ratio for simplicity) = 100 kWh
- Total Energy = 200 kWh

Regenerative Load:

- Energy Consumed = 10 kW * 10 hours = 100 kWh
- Energy Recycled (Assuming 90% efficiency) = 90 kWh
- Net Energy Consumed = 10 kWh
- HVAC Energy (Minimal due to low heat output) ≈ 1 kWh
- Total Energy = 11 kWh

Wide Input Voltage Range

The RLS Series uses a single, constant power voltage input range for both higher current at lower voltage and higher voltage at lower current load testing, eliminating the need to switch between multiple voltage ranges. This capability allows for testing a broad range of conditions and test requirements without interruption.

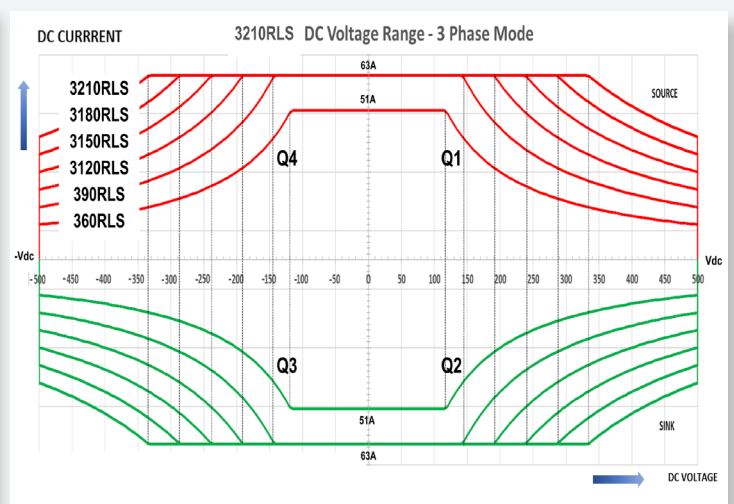
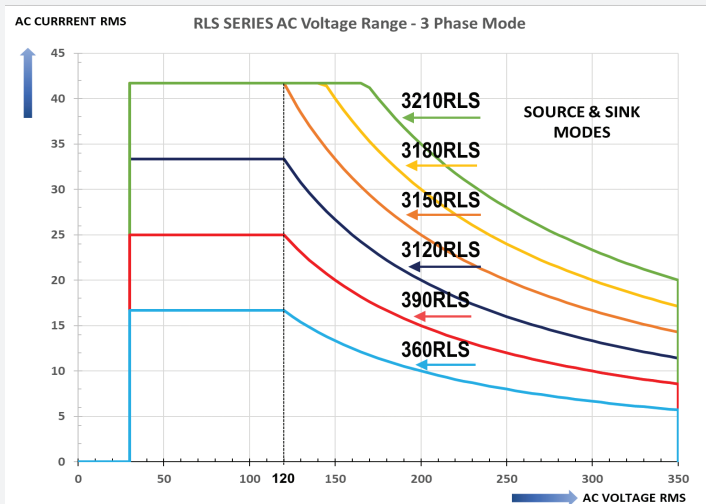

Supports More Current at Low Voltage

The RLS supports a broader range of load current from the UUT.

- Eliminate the risk of over or under sizing the load.
- Reduce the need for additional capital investment.

The RLS is capable of sinking 20% more current from 120V to 200V when compared to a typical unit that maxes out at 35A/phase as shown to the right.

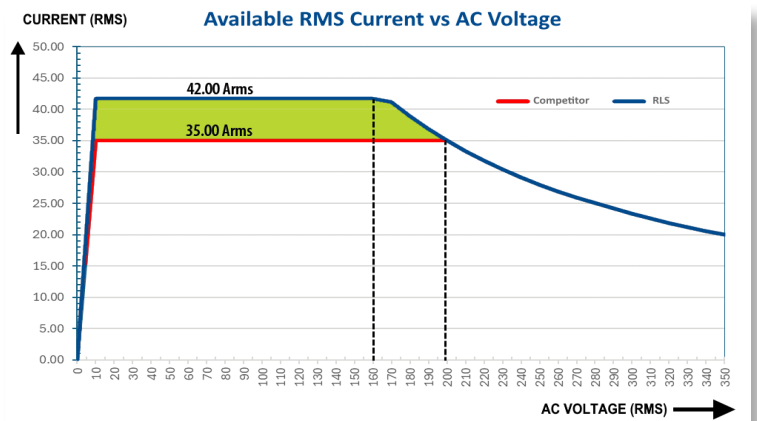

Ultimate Flexibility with Six Input Configurations

Simultaneous AC & DC Operation on Individual Phases

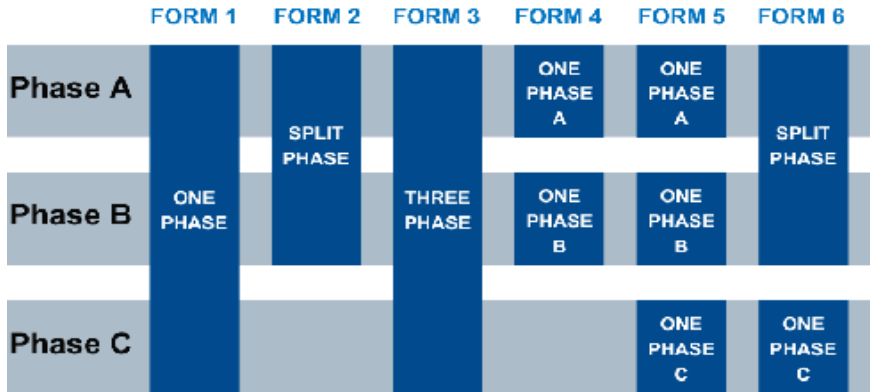

Automatic Switching of Operation Modes

Flexibly test a wide range of EUTs selecting from six different load input configurations.

- Unique input configuration modes allow different functions per phase: AC mode, DC mode or both.
- Forms 1 through 3 are typical for single, split or three-phase AC connections.
- The RLS Series has three isolated neutral connections, one for each phase/channel. This supports testing up to three independent sources.

Fully Test AC Power with 4-Quadrant Load

Simulate AC and DC loads for testing PV inverters, V2G, EV Chargers, EVSE, batteries, UPS, and AC/DC power supplies. Fully operate in all four quadrants using programmable phase shift in CC or CS modes. This allows simulation of inductive and capacitive loads to fully test AC power sources, as shown in the leading and lagging power factor examples.

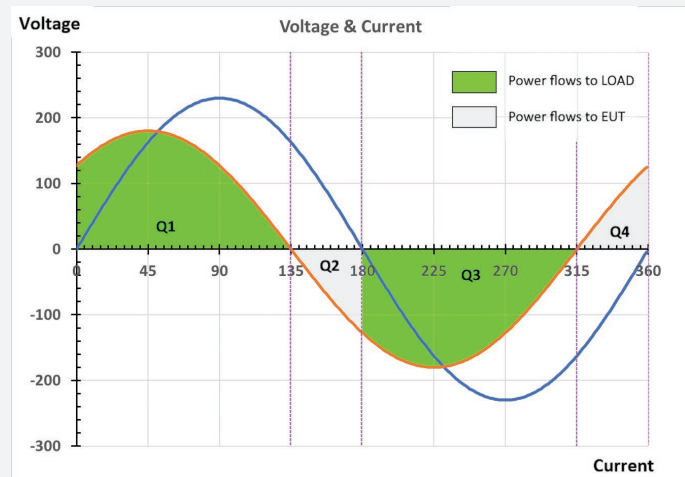
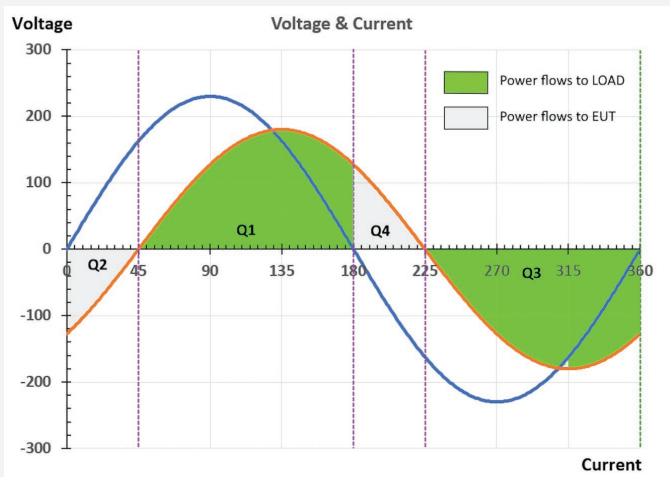

Powerful Waveform & Measurement Tools

The RLS Series has a built-in waveform digitizer with scope function.

- Fast transient capabilities at **200µsec** time resolution
- LIST, PULSE and STEP Transients
- Waveforms: 10 Standard, Sine, Square, Triangle, Clipped
- Includes Harmonics generation (Interharmonics Option)
- Capture advanced measurements and waveforms.



List Mode

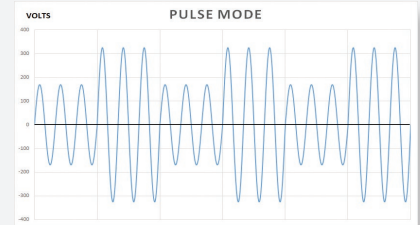

Pulse Mode

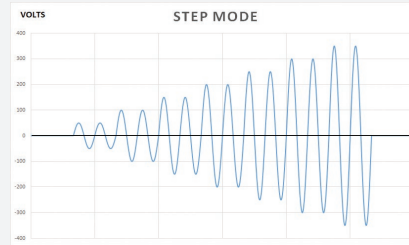

Step Mode

Several AC/DC Load Operating Modes









Simulate AC/DC linear and non-linear loads (rectified), inductive and capacitive loads.





AC Modes:

- Constant Current,
- Constant Power &
- Apparent Power,
- Constant Resistance,
- Constant Voltage
- CC+CR
- CC / CS Rectifier Mode 1 ϕ & 3 ϕ

DC Modes:

- Constant Current
- Constant Power
- Constant Resistance
- Constant Voltage
- CR+CC

AC Load Modes			
	Constant Current (CC)		CR + CC
	Constant Power (CP)		CC / CS Rectifier 1 Phase
	Constant App Power (CS)		CC / CS Rectifier 3 Phase
	Constant Resistance (CR) RMS or Instantaneous Mode		
	Constant Voltage (CV)		

DC Load Modes	
	Constant Current (CC)
	Constant Power (CP)
	Constant Resistance (CR) RMS or Instantaneous Mode
	Constant Voltage (CV)
	CC + CC



User Friendly Control Options

Multiple integrated control options include:

- Intuitive Touch Screen LCD Display with Soft Key driven Menus
- SmartSource Suite Web Interface
- LAN, GPIB, RS232 & USB Interfaces, and ModBus (optional)
- Supports external touch screen monitor via Video Output Interface

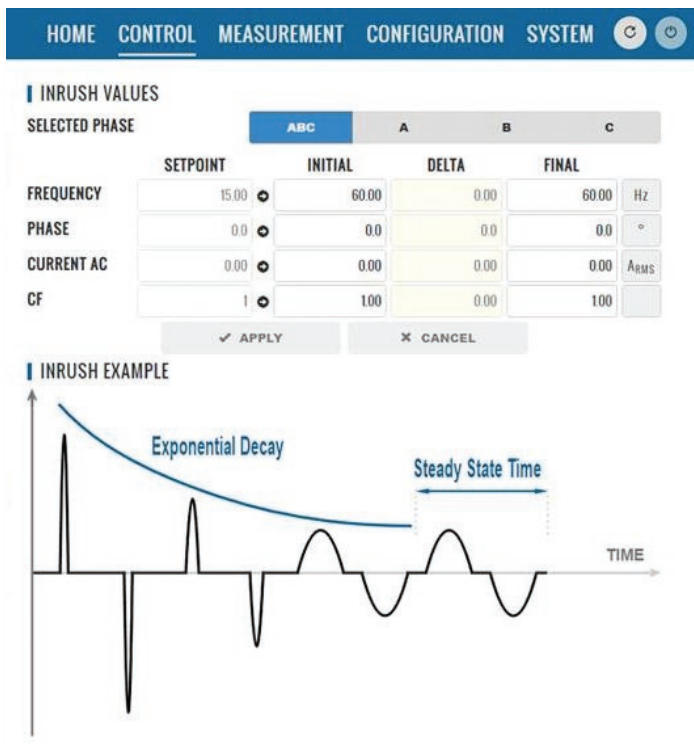

Simplify Test Automation with SmartSource Suite Remote Control Platform

Easily monitor, control, and manage testing with the RLS's SmartSource Suite remote control platform. Use the embedded, web browser interface with real-time control. Access control panels and test sequences on-premises or on any mobile device (laptop, phone, tablet) via secure client access.

- Full control and measurement capability
- Program settings and measurement read back including digital scope and harmonics data
- Extensive safety protection settings
- Advanced load function control screens such as Inrush Current programming shown here
- Waveform selection, preview and edit modes
- Execution of user's custom test sequences
- Transient data entry and execution screen using a spreadsheet layout

Built-in Galvanic Isolation Reduces Safety Risks

The RLS provides both facility-to-input isolation, and phase to phase or channel to channel isolation. Galvanic isolation provides complete separation between the facility power input and the load's inputs so there is no electron flow between channels.

- Channel to channel isolation provides flexibility to use each phase as its own independent power source with FULL frequency and voltage control.
- Fully isolated design reduces safety risks for the operator and prevents unexpected UUT damage by preventing unwanted current or ground loops. This built-in capability doesn't require a transformer which saves significant costs and space.

Modular Power up to 189kW / 378A per Cabinet

The RLS Series provides modular and scalable power to meet changing test requirements. Easily parallel multiple chassis to reach **up to 189kW with 378Amps per cabinet**. Dual cabinets can be paralleled up to 252kW. Three-Phase High Power System configurations available up to 756kW.

- Ease of reconfiguration allows for flexible test set ups and reduces downtime for repairs or maintenance
- Flexibility to scale power now or later as you need it
- Paralleled units can have different power ratings
- Auxiliary no-controller models offer low-cost option
- Complete integrated 19" Rack systems; select from 18U, 32U, and 42U cabinets
- **Parallel configuration kits available** for system integrators using their own cabinets

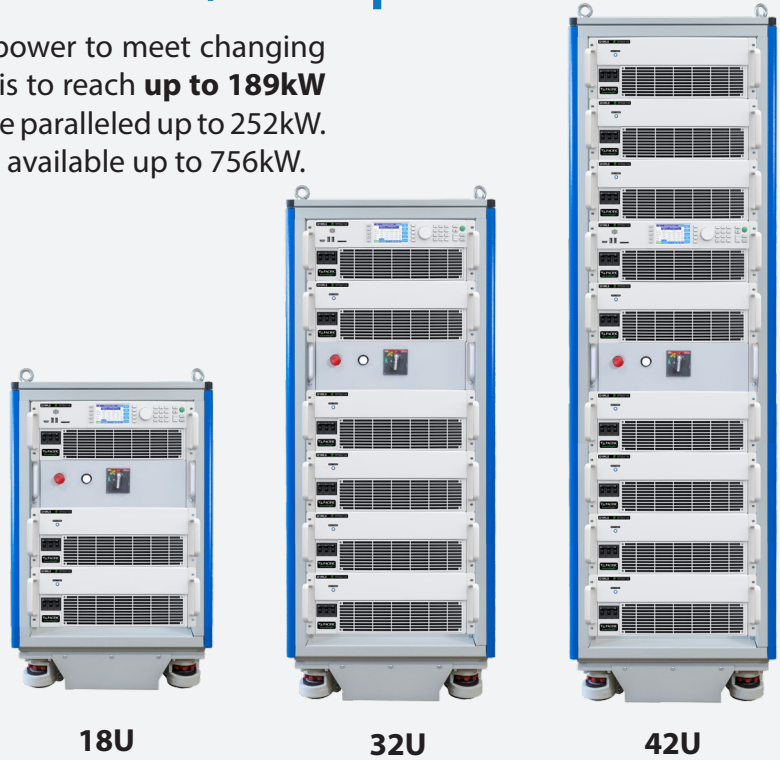

Parallel Systems Installed in 19" EIA Rack Cabinet

MODE	Rated Power ¹ AC / DC mode	Voltage Ranges ² Vac L-N / Vdc	Max. AC/DC Current per phase in 3 & 2 Phase Mode	Rack Space
3240RLS-4U	24 kVA, kW / 24 kW	30-350 Vac / 0-500 Vdc	68.0 Arms / 42.0 Adc	18U
3300RLS-4U	30 kVA, kW / 30 kW	30-350 Vac / 0-500 Vdc	84.0 Arms / 42.0 Adc	18U
3360RLS-4U	36 kVA, kW / 36 kW	30-350 Vac / 0-500 Vdc	84.0 Arms / 42.0 Adc	18U
3420RLS-4U	42 kVA, kW / 42 kW	30-350 Vac / 0-500 Vdc	84.0 Arms / 42.0 Adc	32U
3630RLS-4U	63 kVA, kW / 63 kW	30-350 Vac / 0-500 Vdc	126.0 Arms / 63.0 Adc	32U
3840RLS-4U	84 kVA, kW / 84 kW	30-350 Vac / 0-500 Vdc	168.0 Arms / 84.0 Adc	32U
31050RLS-4U	105 kVA, kW / 105 kW	30-350 Vac / 0-500 Vdc	210.0 Arms / 105.0 Adc	32U
31260RLS-4U	126 kVA, kW / 126 kW	30-350 Vac / 0-500 Vdc	252.0 Arms / 126.0 Adc	32U
31470RLS-4U	147 kVA, kW / 147 kW	30-350 Vac / 0-500 Vdc	294.0 Arms / 147.0 Adc	42U
31680RLS-4U	168 kVA, kW / 168 kW	30-350 Vac / 0-500 Vdc	336.0 Arms / 168.0 Adc	42U
31890RLS-4U	189 kVA, kW / 189 kW	30-350 Vac / 0-500 Vdc	378.0 Arms / 189.0 Adc	42U
32100RLS-4U	210 kVA, kW / 210kW	30-350 Vac / 0-500 Vdc	420.0 Arms / 210.0 Adc	2 x 32U
32310RLS-4U	231 kVA, kW / 231 kW	30-350 Vac / 0-500 Vdc	462.0 Arms / 231.0 Adc	2 x 32U
32520RLS-4U	252 kVA, kW / 252kW	30-350 Vac / 0-500 Vdc	504.0 Arms / 252.0 Adc	2 x 32U

Three-Phase High Power System configurations are available up to 756kVA/kW; contact Factory for details.

Note 1: For Split Phase mode, rated power is 2/3.

Note 2: For Voltage ranges above 333Vac some frequency and Vthd restrictions apply.

Contact factory for cabinet output wiring modifications to support single phase AC mode on cabinets above 84

Parallel configuration kits available for system integrators using their own cabinets.

Technical Specifications

MODEL:	360RLS-4U	390RLS-4U	3120RLS-4U	3150RLS-4U	3180RLS-4U	3210RLS-4U
Modes of Operation						
Constant Current, Constant Power & Apparent Power, Constant Resistance, Constant Voltage, CC+CR, CC / CS Rectifier Mode						
AC or DC Input Power						
Phase Modes (Form)	1, 2 or 3	1, 2 or 3	1, 2 or 3	1, 2 or 3	1, 2 or 3	1, 2 or 3
Maximum Power ¹ (Total)	6 kW/kVA	9 kW/kVA	12 kW/kVA	15 kW/kVA	18 kW/kVA ¹	21 kW/kVA ¹
Per Phase / Channel	2 kW/kVA	3 kW/kVA	4 kW/kVA	5 kW/kVA	6 kW/kVA	7 kW/kVA
Load Input Voltage						
Input Range	AC Range: 30 - 350 V _{LN} / 50 - 606 V _{LL} RMS (Sync Mode) DC Range: 0 - ±500 V _{DC}					
Resolution	0.01			Accuracy:	± 0.25% F.S	
Line Regulation	< 0.1% for 10% Line Change					
Current Regulation	± 0.02% (CSC Mode)					
Phase Angle - Range (B, C)	0 - 359.9°				Resolution:	0.1°
Maximum Current						
3 & 2 Phase modes AC / DC	17.0 ARMS/ 17.0 ADC	25.0 ARMS/ 21.0 ADC	34.0 ARMS/ 21.0 ADC	42.0 ARMS/ 21.0 ADC	42.0 ARMS/ 21.0 ADC	42.0 ARMS/ 21.0 ADC
1 Phase mode AC / DC	51.0 ARMS/ 51.0 ADC	75.0 ARMS/ 63.0 ADC	100.0 ARMS/ 63.0 ADC	126.0 ARMS/ 63.0 ADC	126.0 ARMS/ 63.0 ADC	126.0 ARMS/ 63.0 ADC
Current Crest Factor (AC)	6.2 : 1	4.2 : 1	3.0 : 1	2.5 : 1	2.5 : 1	2.5 : 1
Load Input Frequency						
Range	15.00 – 1200Hz					
Mains Input						
Input Voltage Range / Freq	380Vac – 480Vac ± 10%, 4 Wire, L1, L2, L3 and PE / 47 - 63 Hz					
Nom. Phase Current @ 400Vac / 480Vac	10ARMS/8ARMS	14ARMS/12ARMS	19ARMS/16ARMS	24ARMS/20ARMS	29ARMS/24ARMS	34ARMS/28ARMS
Input Power Factor	0.99				Efficiency:	> 0.90
Measurements						
Vrms Range / Accuracy	0 – 350 V _{LN} / 0-606 V _{LL} / ± 0.25% F.S.					
Irms Range ² / Accuracy	17.0 A / ± 0.5% F.S.	25.0 A / ± 0.5% F.S.	34.0 A / ± 0.5% F.S.	42.0 A / ± 0.5% F.S.	42.0 A / ± 0.5% F.S.	42.0 A / ± 0.5% F.S.
Power Range ² / Accuracy	2 kW / ± 1.5 % F.S.	3 kW / ± 1.5 % F.S.	4 kW / ± 1.5 % F.S.	5 kW / ± 1.5 % F.S.	6 kW / ± 1.5 % F.S.	7 kW / ± 1.5 % F.S.
Scope Function	Sample Rate: 54932.47 Hz / Window: 1024 Samples / Bandwidth: 1200 Hz					
Transient Functions						
Programming	200 Steps / 400 Segments, LIST, PULSE & STEP Modes, Current AC, Current DC, Waveform, Ramp Time, Dwell Time. Time range: 0.1 - 10000000.0 ms, Time resolution 0.2 ms					
Execution	Run from step # to step #, Run, Step, Restart, Stop			Storage:	Non-volatile, 100 Programs + Transients	
PARAMETERS / FUNCTIONS SPECIFICATIONS						
Remote Control Interfaces						
USB Type B, LAN (LXI), GPIB / IEEE488, RS232, all on rear panel; External USB WIFI adapter / ModBus TCP / CAN/CAN-FD						
Analog & Digital I/O						
Analog Inputs (4): AI1, AI2, AI3, AI4 User defined functions.				Analog Outputs (4): AO1 AO2, AO3, AO4 User-defined measurement functions		
Digital Inputs (6) / Outputs(6)	Remote Inhibit, Trans. Trig., Phase Sync, User			Output Relay, Transient, Function Strobe, Sync		
Environmental						
Cooling	Variable speed fan, front intake, rear exhaust			Energy Modes:	Standby & Sleep	
Temperature	Operating:	0 to 40 °C / 32 to 104 °F		Storage:	-20 to 70 °C / -4 to 158 °F	
Humidity	< 80%, non-condensing			Altitude:	2000 m / 6500 feet	
System Features						
USB Ports	2 on Front Panel, 1 on Rear Panel, All Type A			SD Card:	32 GB max. Capacity	
Video Output Port	Monitor Out, Front Panel					
Dimensions & Weights						
Chassis Size H x W x D	7.0" x 17.0" x 25.0" / 178 x 432 x 635 mm			Shipping: 20" x 27" x 38" / 508 x 686 x 965 mm		
Weight Single 4U Height Unit	Net:	111.2 lbs. / 50.4 kg		Shipping: 151 lbs / 68.5 kg		
Regulatory Compliance						
Safety	IEC 61010-1:2010 (Edition 3)					
EMC - Emissions / Immunity	EN 55011:2009+A1:2010 / EN 61000-4-2, -4-3, -4-4, -4-5, -4-6, -4-8 and EN 61000-4 -11					
Product Category	EN 61326-1:2013 (Measurement, Laboratory and Control Equipment)					
Agency Approvals	CE Mark, NRTL Nemko US/Canada			RoHS (2011/65/EU):	EN50581:2012	

Note 1: Maximum Power rating is reduced below 40Hz on 3180RLS and 3210RLS models

Ordering Information

RLS Series Model Number Encoder:

Note: Solid outlined fields must be specified. Dashed outlined fields are optional.

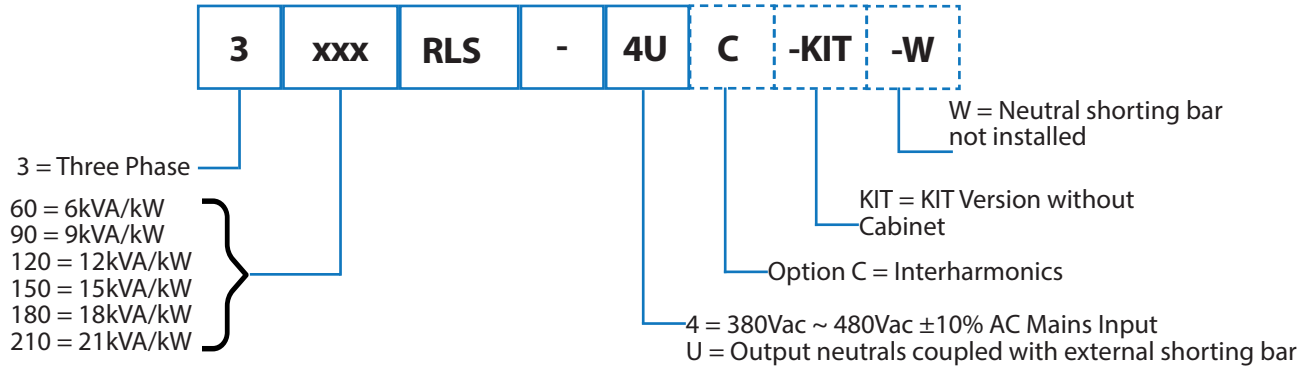

NOTE: 4U indicates that the shorting bar for output neutrals will be installed on the units by default. If Option W is selected, the units will be shipped with shorting bar for neutrals removed and provided in the ship kit instead.

Parallel load Kits:

These kits are available in power ratings of 24kW, 30kW, 36kW, 42kW and higher in increments of 21kW up to 252kW (12 chassis) max. For turnkey, integrated parallel load cabinet systems, contact factory.

Order Example 3210RLS-4W

- Bench Model, 21 kVA, 3-Phase, Regenerative Electronic Load, USB, RS232, LAN, GPIB & AUX I/O, Isolated Neutrals

Typical Delivery Items

- Electronic Load
- Rack Mount Handles
- Certificate of Compliance

Available Accessories

- Input shorting adapter for single phase input mode use. P/N 160086 (not for W)
- Paralleling Cable, 1 Ft. (Included with Aux NC models). P/N 778036
- Rack slides. P/N 703251

Auxiliary Models (No controller) Order Example: 3210RLS-4UNC

Worldwide Service & Support

NORTH AMERICA

Pacific Power Source, Inc.
Irvine, USA
Phone: +1(949) 251-1800
Fax: +1 (949) 756-0756
Email: sales@pacificpower.com
Web: www.pacificpower.com

EUROPE

Pacific Power Source Europe GmbH.
Kappelrodeck, Germany
Phone: +49 7842 99722-20
Fax: +49 7842 99722-29
Email: info@pacificpower.eu

UNITED KINGDOM

Caltest Instruments Ltd.
Petersfield, UK
Phone: +44 (0) 1483 302 700
Email: sales@caltest.co.uk

CHINA

PPST Shanghai Co. Ltd.
Shanghai, China
Phone: +86-21-6763-9223
Fax: +86-21-5763-8240
Email: info@ppst.com.cn

2802 Kelvin Avenue, Suite 100
Irvine, CA 92614 -5897 USA
Phone: +1 949.251.1800
Toll Free: 800.854.2433
E-mail: sales@pacificpower.com
Web: www.pacificpower.com