

Features

- 12th/13th/14th Generation Intel® Core™ & Series 2 Processors, up to 65W
- DDR5 SODIMM 5200 x 2, up to 64GB
- HDMI 2.0 x 1 (Main Board), DP++ 1.4 x 2 (via MXM Module)
- 2.5GbE x 5, 1GbE x 1
- USB 3.2 Gen 2 x 4, USB 2.0 x 2
- M.2 2280 M-Key x 2, M.2 3052 B-Key x 1, Mini Card x 1
- Supports MXM 3.1 Type A/B Module, up to TGP 120W
- COM x 4, GPIO 16-bit, DC 19V-24V



Speaker	—
External I/O	
Ethernet	Intel® Ethernet Controller I226-LM, 2.5GbE RJ-45 x 2, from FPC (optional) Intel® Ethernet Controller I226-V, 2.5GbE RJ-45 x 3 Intel® Ethernet Connection I219-LM, GbE RJ-45 x 1
USB	USB 3.2 Gen 2 x 4, USB 2.0 x 2
Serial Port	—
Video	HDMI 2.0 x 1, up to 3840 x 2160 @60Hz (from Main Board) DP++1.4 x 2, up to 3840 x 2160 (from MXM Module, optional)
Internal I/O	
USB	—
Serial Port	COM 1 ~ COM 4 (RS-232/422/485 x 2 + RS-232 x 2, RI as default, 5V/12V selected by BOM change)
Video	—
SATA	SATA 6Gb/s x 1 (Optional)
Audio	Audio Header x 1
DIO/GPIO	GPIO-16 bits
SMBus/I2C	SMBus (Default) / I2C
Touch	—
Fan	4-Pin Smart Fan (CPU) x 1, 3-Pin Fan (MXM Module) x 1, System Fan x 1
SIM	Nano SIM x 1
Front Panel	Power Button, Power LED
Others	—
Expansion	
Mini PCI-E/mSATA	—
M.2	M.2 2280 M-Key x 2 (PCIe 4.0 [x4] x 1 + PCIe 3.0 [x4] x 1) M.2 3052 B-Key x 1 (PCIe 3.0 [x2] + USB 3.2 + USB 2.0) Full-size Mini Card x 1 (PCIe 3.0 [x1] + USB 2.0)
Others	MXM 3.1 Type A / Type B Module slot, TGP up to 120W
Environment & Certification	
Operating Temperature	32°F ~ 122°F (0°C ~ 50°C) with 0.5m/sec airflow
Storage Temperature	-40°F ~ 185°F (-40°C ~ 85°C)
Operating Humidity	0% ~ 90% relative humidity, non-condensing
MTBF (Hours)	768,724
EMC	CE/FCC Class A

Specifications

System	
Form Factor	MXM System
CPU	12th/13th/14th Generation Intel® Core™ & Intel® Core™ Series 2 Processors, up to 65W
Chipset	Intel® R680E Chipset Intel® Q670E Chipset Intel® H610E Chipset (Optional)
Memory Type	Dual Channel DDR5 SODIMM x 2, up to 5200, 64GB (ECC support for R680E SKU only) Note: DDR speed is dependent on CPU SKU
BIOS	UEFI
Wake On Lan	Yes (Onboard LAN only)
Watchdog Timer	255 Levels
Security	TPM 2.0
RTC Battery	Lithium Battery 3V/240mAh
Dimension	11.6" x 7.3" x 1.9" (295mm x 186mm x 50mm)
OS Support	Windows® 10 (Versions 22H2 and later) Windows 11 Ubuntu 24.04 Kernel 6.11
Power	
Power Requirement	+19V ~ +24V
Power Supply Type	AT/ATX
Connector	4-pin Phoenix Connector
Power Consumption	Intel® Core™ 7 251E, DDR5 32GB x 2, 6.58A @24V, 157.92W (Typical) Intel® Core™ 7 251E, DDR5 32GB x 2, 12.16A @24V, 291.84 (Max)
Display	
Controller	CPU Graphic Controller Intel® UHD Graphics 770 (i5 SKU and above) Intel® UHD Graphics 730 (i3 SKU)
LVDS/eDP	—
Display Interface	HDMI 2.0 x 1, up to 3840 x 2160 @60Hz (from Main Board) DP++ 1.4 x 2 (from MXM Module, optional)
Multiple Display	1 Display from Main Board Up to 2 Simultaneous Displays from MXM Module
Audio	
CODEC	Realtek ALC897
Audio Interface	Line-In/Line-Out/Mic

Packing List

- MEX-BTS
- CPU Cooler Bracket

Optional Accessories

Part Number	Description	Qty
1702031802	Power Cord (US Type)	1
1702031803	Power Cord (Europe Type)	1
170203180E	Power Cord (Japan)	1
AP-PS1255X00133	AC/DC Adapter.Input=90-264VAC&Output=24VDC.400W.16.66A.POWER-WIN.A10400-24	1
PER-T699-A02-0001	PER-T699-2.5G Dual LAN card	1
14CX000148	Intel Core 5 Processor 211E	1
14CX000143	Intel Core 7 Processor 251E	1





Block Diagram

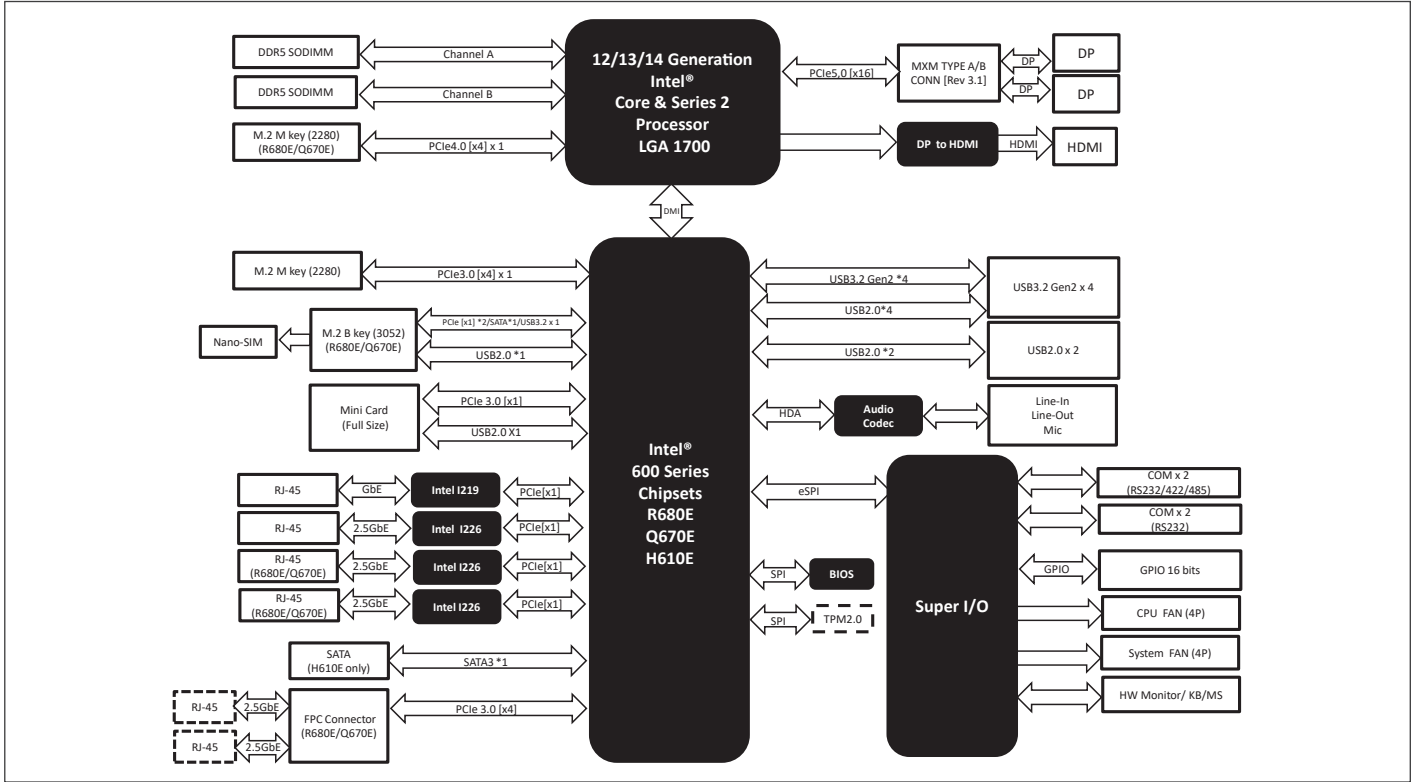

Dimension Unit: mm

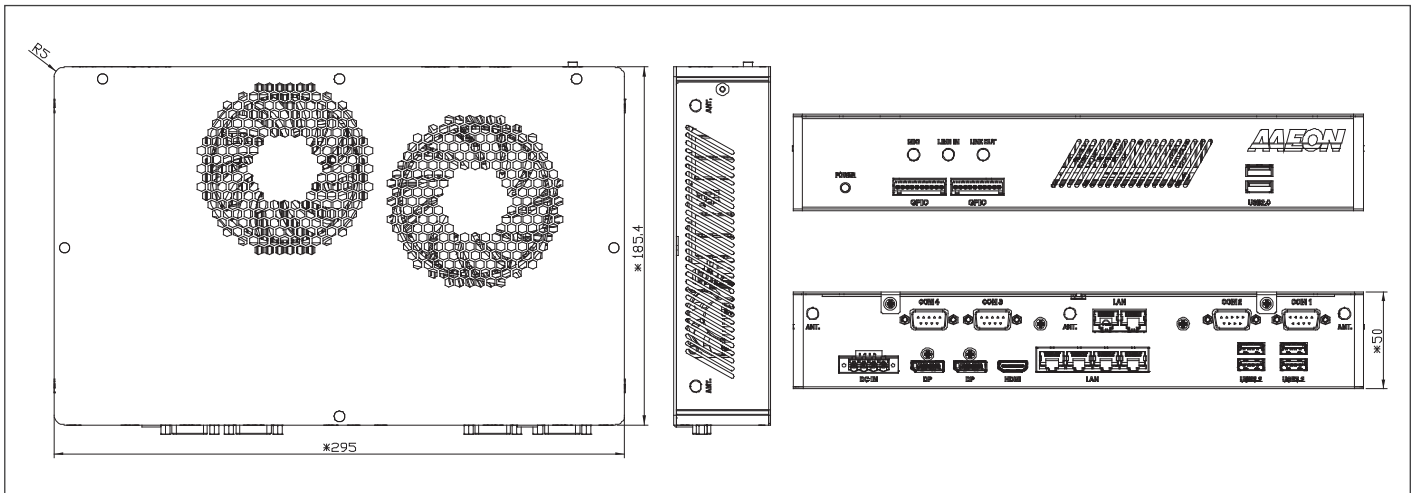

Ordering Information

Part Number	CPU	Memory	Display	Storage	LAN	USB	COM Port	Expansion	TPM	Power	Operating Temperature	Others
MEX-BTS-A10-0001	LGA 1700 up to 65W R680E PCH	DDR5 SODIMM x 2 (ECC)	HDMI x 1 (onboard) DP x 2 (From MXM)	—	2.5GbE x 5, GbE x 1	USB 3.2 Gen 2 x 2, USB 2.0 x 4	RS-232/422/485 x 2, RS-232 x 2	M.2 2280 M-Key x 2 M.2 3052 B-Key x 1 Full Size Mini Card x 1 MXM 3.1 Connector (PCIe4.0[x16] x 1)	TPM 2.0	+19V to +24V AC power connector	0°C – 50°C	Nano SIM x 1 GPIO 16 bit Audio x 1
MEX-BTS-A10-0002	LGA 1700 up to 65W Q670E PCH	DDR5 SODIMM x 2	HDMI x 1 (onboard) DP x 2 (From MXM)	—	2.5GbE x 3, GbE x 1	USB 3.2 Gen 2 x 2, USB 2.0 x 4	RS-232/422/485 x 2, RS-232 x 2	M.2 2280 M-Key x 2 M.2 3052 B-Key x 1 Full Size Mini Card x 1 FPC x 1 MXM 3.1 Connector (PCIe4.0[x16] x 1)	TPM 2.0	+19V to +24V AC power connector	0°C – 50°C	Nano SIM x 1 GPIO 16 bit Audio x 1