

# Matchstiq™ Z4

**EARLY ACCESS**



SWaP-Optimized, Modular 6 GHz SDR Platform with Low Power Sleep Modes & Event-based Wake-up

**Robust Four Channel Software Defined Radio Platform with Powerful On-board Processing and Optional Storage for Spectrum Search, Direction Finding (DF) and Transmit Applications.**

The Matchstiq™ Z4 builds on the strong heritage of the Epiq Matchstiq Z2 and Z3u models which are valued for their small size, weight, and power consumption combined with on-board processing to allow self-contained signal acquisition without the need for an external host. The Matchstiq Z4 takes this further with four RF ports that can be flexibly assigned as transmit or receive, independent or coherent, and also provides enhanced RF performance. It can be battery-operated from an external 9 – 28 Vdc supply, and the integrated system controller enables different power modes, drawing as little as 72 mW, up to full system operation consuming only 10-20W.



## Key Features

- Low SWaP Platform for payload, leave-behind and other demanding applications
- Integrated system controller and real-time clock (RTC) enabling time, GPS geo-location or GPIO-based wakeup from low power mode
- Four RF ports dynamically assignable to transmit or receive, 10 MHz to 6 GHz and 50 MHz instantaneous bandwidth
- Independent or coherent operation for DF in an extremely small package

Product Web Page:



## Specifications at a Glance

Category	Output	F <sub>Min</sub>	F <sub>Max</sub>	Frequency Tuning	Timing Inputs	CPU Enabled	GPU Enabled
Platform	Digital	10 MHz	6 GHz	Indep. & Coherent	10 MHz, PPS, GPS	Yes	No
Max Rx Channels	Max Tx Channels	IBW <sub>Max</sub>	SFDR <sub>Typ.</sub>	Weight	Typ. Power Consumption	Interfaces	ADC bits/ DAC bits
4	4	50 MHz	70 dB	1.2 lb. 0.55 kg	<20 W	USB	16/ 16

## Specifications

<b>Model:</b>	<b>Z4</b>	
<b>Environmental Specifications</b>		
Temperature (Operating)	-40 to +70 °C, cold plate surface temperature under typical operating conditions	
Temperature (Storage)	-40 to +85 °C	
Size	6.0 x 3.5 x 1.14 inches 152 x 89 x 29 mm	
Weight	1.2 lb. 0.55 kg	
Power (Typ.)	Micro Power Mode	<72 mW on 12 Vdc input
	Low Power Mode	<120 mW on 12 Vdc input
	Full Power Mode	10 – 20 W on 12 Vdc input
Voltage Input Range	9 – 28 V; 12 Vdc nominal User accessible CR1225 3V coin cell for real-time clock and state retention	
Enclosure	Metal	
<b>Digital Specifications</b>		
FPGA	Zynq Ultrascale+ ZU7	
CPU/ GPU	Quad-core ARM Cortex A53 CPU (64-bit)/ No GPU	
Memory	128 GB eMMC, 4 GB DDR4 (PS), 4 GB DDR4 (PL)	
Storage	2x M.2 2280 key M sockets for SSDs and other functions. Factory options installed at time of order, not user-accessible.	
User I/O	USB-C access to USB 3.0 host – data export	
	USB-C maintenance access to serial console (UART) & JTAG	
	microSD slot on front panel. System capable of secure boot from suitable user-supplied card.	
	User accessible GPIO through front panel connector	
	System LEDs – GPS fix LED on RF interfaces panel, tri-color LED on digital interfaces panel.	

<b>Model:</b>	<b>Z4</b>	
<b>Other</b>		
Export Classification	5A991.b	
CE-Marked	-	
<b>RF Specifications</b>		
<b>All</b>		
Connector Types	SMA Female	
Frequency Range	10 MHz to 6 GHz	
Maximum Sample Rate	61.44 MS/s	
Channel Bandwidth	Up to 50 MHz/ Channel	
Tuning Operation	All channels can be independent, or operated coherently <sup>[1]</sup>	



(Antennas not included)

[1] For timing of 4 channel coherent transmit feature, contact Epiq.

## Specifications

<b>Model:</b>	<b>Z4</b>	
<b>RF Specifications</b>		
<b>Receive</b>		
Channels	Assignable up to 4 total	
Maximum RF Input Level	+20 dBm	
RF Pre-Select Filters	Sub-octave pre-selection filters from 100 MHz to 6 GHz	
Tuning Time <sup>[1]</sup>	<120 $\mu$ s	
Noise Figure (Typ.)	1 GHz	6 dB
	3 GHz	8 dB
	6 GHz	10 dB
Input IP3 (Typ.) <sup>[2]</sup>	1 GHz	15 dB
	3 GHz	15 dB
	6 GHz	15 dB
Spurious Free Dynamic Range (Typ.) <sup>[3]</sup>	1 GHz	80 dBc
	3 GHz	80 dBc
	6 GHz	80 dBc
Internal Spurs <sup>[4]</sup>	1 GHz	-100 dBm
	3 GHz	-100 dBm
	6 GHz	-100 dBm
A/D Bits	16	
Receive Snapshot Mode	All four receive channels can stream at full rate to 2 GB of DDR memory. Four channels at 61.44 MS/s equates to 2 seconds of capture.	

<b>Model:</b>	<b>Z4</b>	
<b>RF Specifications</b>		
<b>Transmit</b>		
Channels	Assignable up to 4 total	
Typical Output Power	+5 dBm	
D/A Bits	16	
Spurious Free Dynamic Range (Typ.) <sup>[5]</sup>	70 dBc	
Tuning Time <sup>[6]</sup>	<120 $\mu$ s	
<b>Clocking</b>		
Reference	10 MHz (MMCX Connector)	
PPS Input	Yes (MMCX Connector); 1,8V LVCMOS nominal, 5V max	
GPS Input	Yes (50 $\Omega$ SMA)	

*Data subject to change without notice.*



*Z4 with optional Fan Kit.*  
(Antennas not included)

[1] Tuning between any two frequencies over operating range

[2] Measured with 2 CW tones at -9 dB-full-scale of the A/D input power

[3] Highest in-band spur compared against a single CW tone at -9 dB-full-scale of the A/D

[4] Highest in-band spur translated to equivalent power at the Rx input connector

[5] Single tone spurious-free dynamic range, excluding harmonics and inter-modulation products, referenced to a CW output tone a -3dB full scale of the DAC

[6] Tuning between any two frequencies over operating range

## Z4 Block Diagram

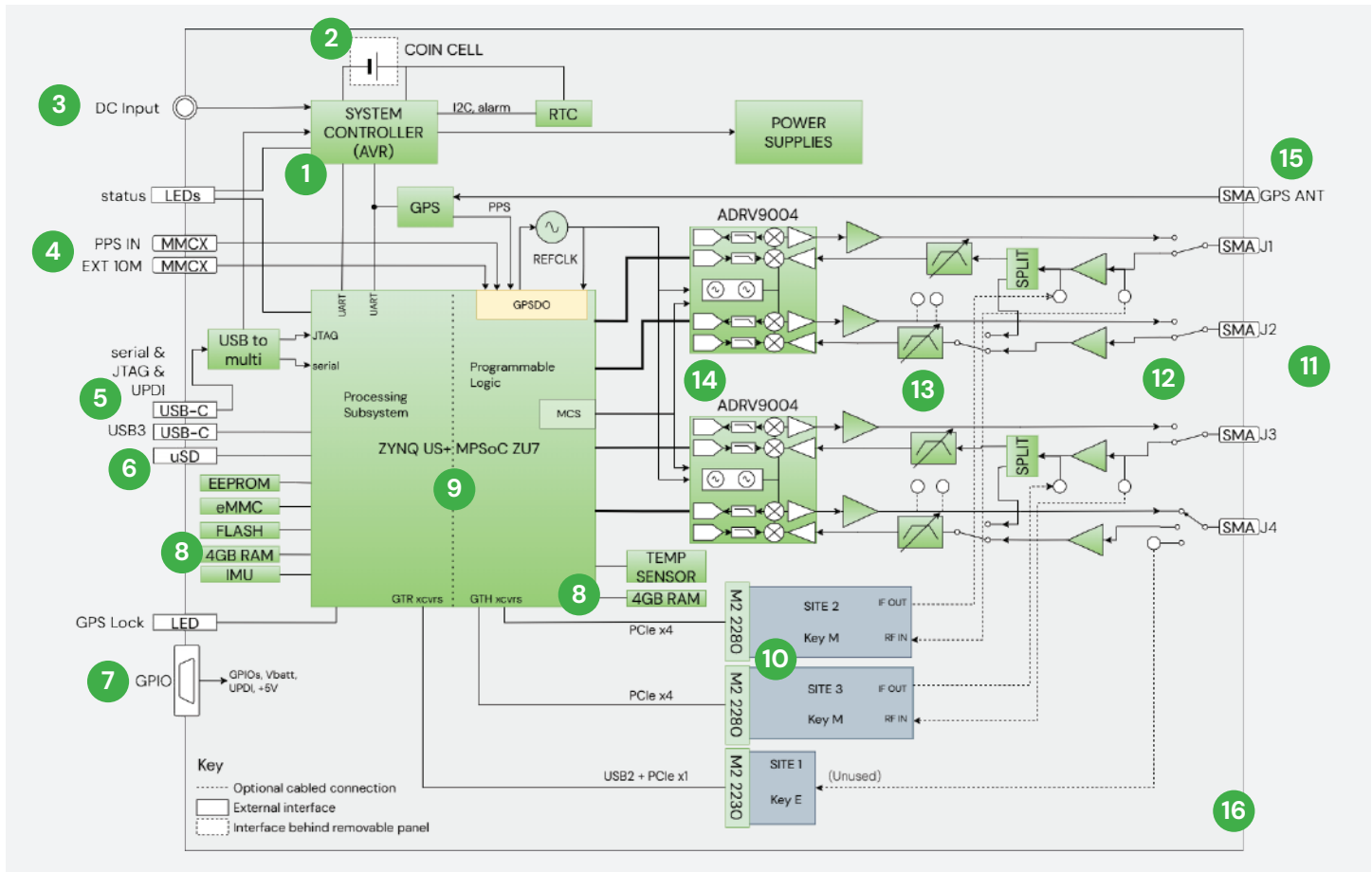

### Features of Note

Numbered items may be highlighted on the block diagram and/or exploded view.

- 1 New system controller with Real-time clock (RTC)
- 2 Replaceable 3V coin cell to maintain settings
- 3 9 - 28 Vdc input (Lemo Series B)
- 4 PPS and 10 MHz reference inputs (MMCX)
- 5 Host and serial interface connectors (USB-C). Note that the serial USB-C also allows JTAG-over-USB
- 6 microSD card slot (card not supplied) & adjacent status LED
- 7 GPIO connector on front (digital) panel (Omnetics MNSO series)
- 8 4 GB (PS) and 4 GB (PL) memory
- 9 Zynq Ultrascale+ ZU7
- 10 Dual M.2 2280 card slots for storage and other future functions. At launch a factory-installed 2 TB solid state drive is offered as an option.
- 11 J1 - J4 assignable RF ports (SMA)
- 12 Rx/Tx switching
- 13 Sub-octave RF pre-selection filters
- 14 Dual ADRV9004 RFICs with independent LOs and coherent operation
- 15 GPS antenna input (SMA)
- 16 Single RF & processing PCB
- 17 Thermal pads\*
- 18 Cold-plate surface (top)\*
- 19 Robust metal enclosure\*

\* Visible on exploded view only

# Anatomy of a Z4

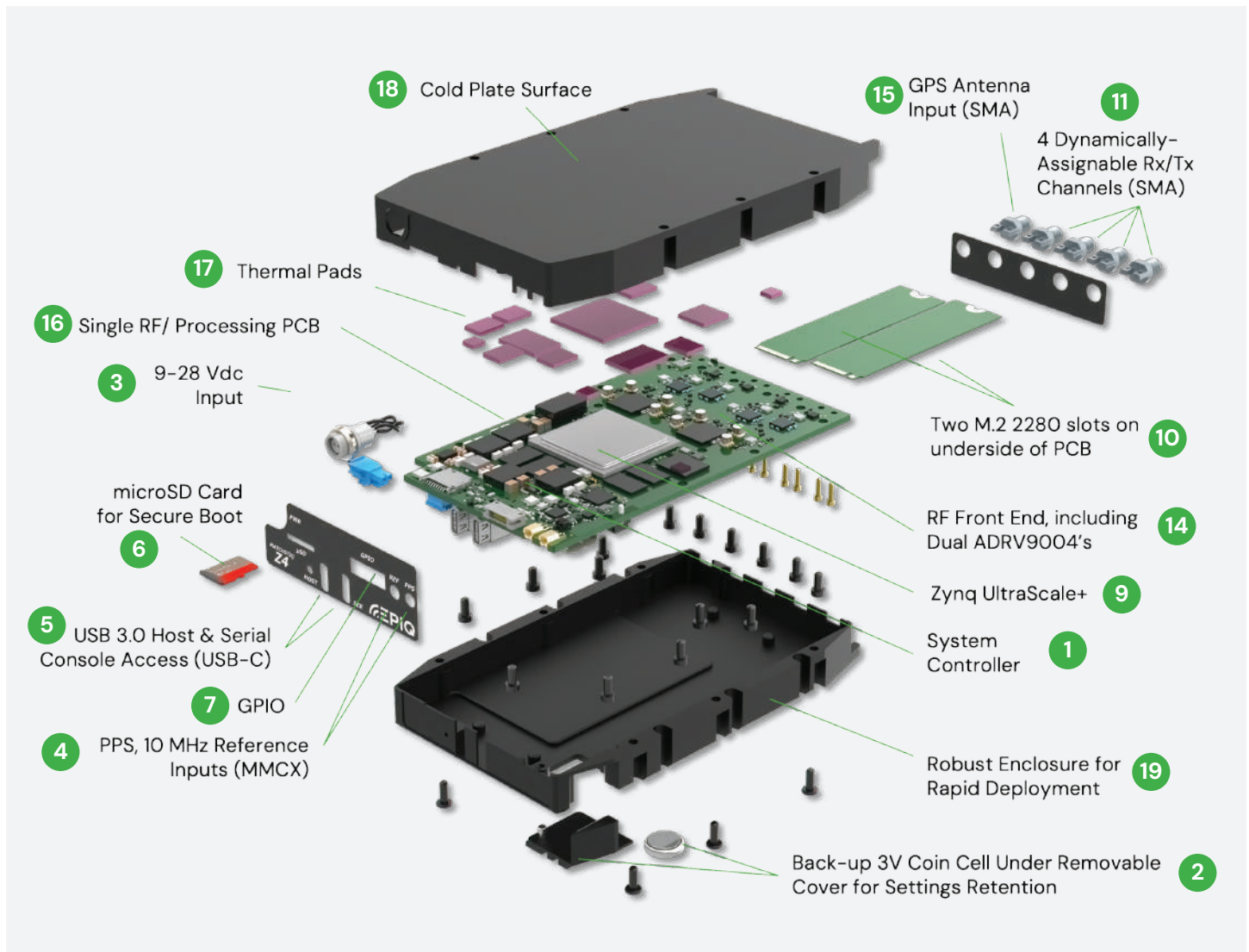

Matchstiq Z4 pictured with the Z3u (center) and Z2 (far). The Z4 continues the tradition of small, self-contained SDRs equipped for field use.

## Z4 Features

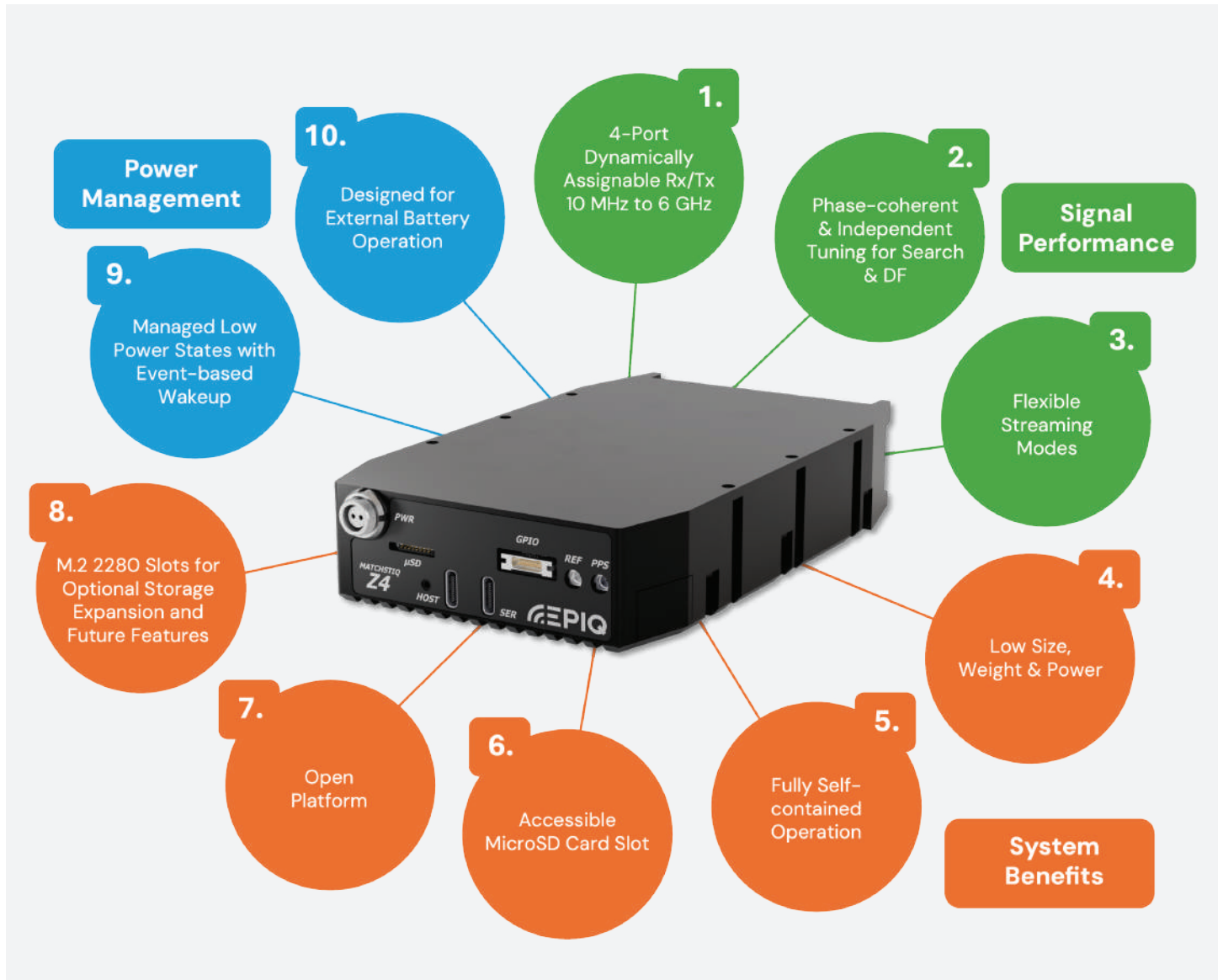

## Signal Performance

1.

### Flexible RF Ports

The four rear panel RF ports can be dynamically assigned between transmit and receive and offer coverage from 10 MHz to 6 GHz with up to 50 MHz instantaneous bandwidth per channel at 61.44 MS/s. Receive and transmit channels are 16-bit with improved RF performance, including spurious free dynamic range (SFDR) of 80 and 70 dBc (typical) respectively. Receive paths include sub-octave pre-selection filters from 100 MHz to 6 GHz.

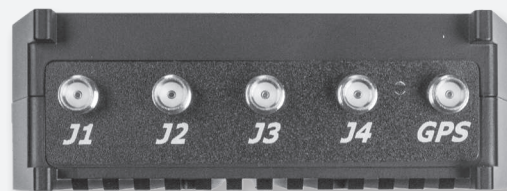

2.

### Phase-coherent & Independent Channels Ideal for Search & DF

The four ports on the Z4 can be assigned as transmit or receive at any point in time. They are also independently tunable or can be assigned to be phase coherent. This opens up possibilities like the following:

- 2 Receive, 2 Transmit for a MIMO application
- 4 Receiver, 0 Transmit, phase coherent for Direction Finding (DF)
- 4 Receive, 0 Transmit, independently tuned to explore four different UAS bands for Counter-UAS.  
...or rapidly change it all up again for the next task.

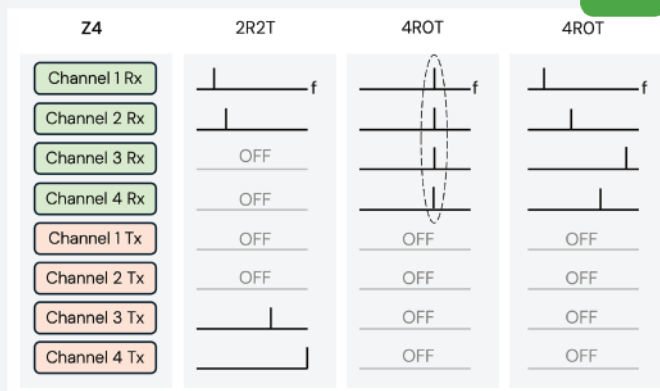

3.

### Flexible Streaming Modes

The Z4 supports flexible streaming modes.

1. Stream over 100 MHz of RF data between the CPU and FPGA for continuous streaming use cases that need receive, transmit, or concurrent transmit/receive.
2. The FPGA has access to the full 200 MHz from both the receive and transmit channels. Custom FPGA designs can be integrated into the existing design that decimate down or interpolate up data streams from the CPU, or process data entirely on the FPGA.
3. The Z4 also supports the new receive Snapshot Mode; the system has an ability to use RAM attached to the FPGA to capture a snapshot of full rate data that can then be stored or exported at a lower rate.

The system supports capture of up to 4 GB of digitized RF data, from up to four receive channels. For survey applications, for example, this allows a unit to wake up at timed intervals, take predefined snapshots of spectrum, and then store them away for later analysis.

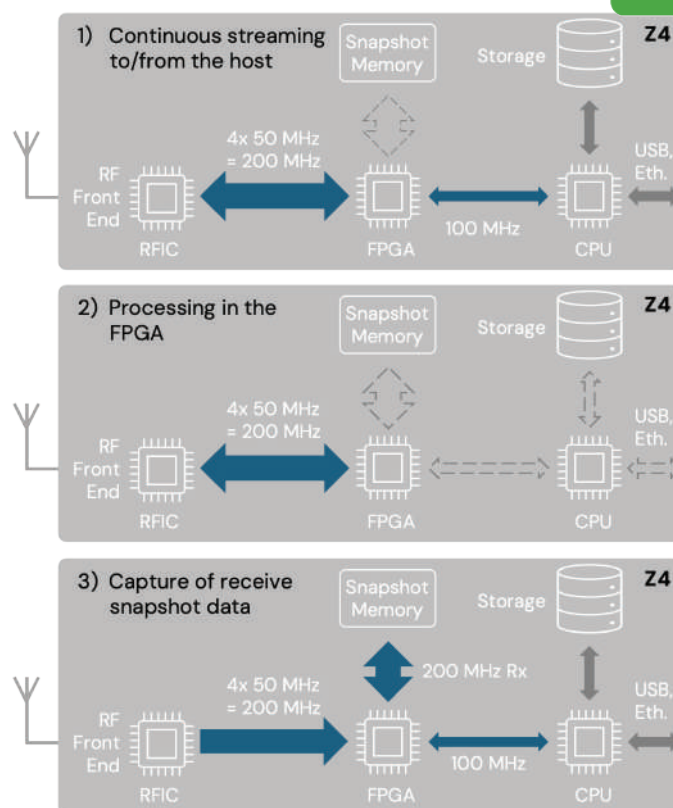

## System Benefits

### Low Size, Weight & Power

In keeping with the Epiq's focus on small form factor (SFF) SDR products, considerable care has been taken to optimize for size, weight and power (SWaP). Weighing in at only 1.2 lb. (0.55 kg), it takes up less than 25 inch<sup>3</sup> and typically consumes somewhere in the range of 10 to 20 W in normal use. This makes it an ideal candidate for payload applications.

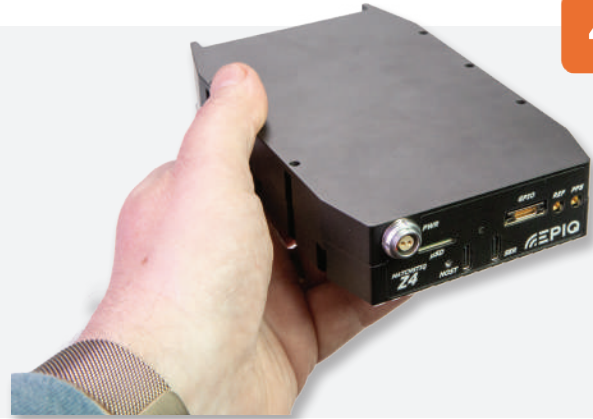

4.

### On-Board ARM Processors Enable Fully Self-contained Operation

The Epiq Sidekiq Z2, and Matchstiq Z2 and Z3u SDRs are some of the smallest SDRs on the market offering Ultrascale+ MPSOC integration capable of running full Linux applications on-board. With only the addition of a battery and antennas, they offer fully self-contained operation. The new Matchstiq Z4 continues this tradition with increased processing power, making it ideal for UxS payloads, leave-behind survey and many other uses. Example applications include Epiq's Skylight cellular survey tool, 3 dB Labs' Sceptre and Distributed Spectrum's RF Vision.

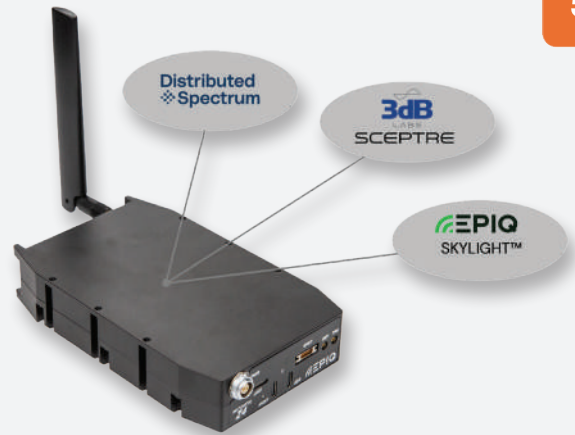

(Antennas not included)

5.

### microSD Slot

The front panel card slot gives users the option to supply their own microSD card for secure boot purposes or data storage.



6.

### Open-Source Platform

Epiq's popular Libsidekiq, which enables the Z4, makes it simple to switch between many of our radios depending upon need. It also enables compatibility with a wide variety of open-source frameworks such as GNU Radio, SDR++, Gqrx, SDRangel and SoapySDR. High quality I/Q data is available over the high speed USB 3.0 interface.

For those with the desire to do custom FPGA development, we've got that covered. Through the Matchstiq Z4 platform development kit (PDK), creation of novel techniques, on-the-fly FFT processing, equalization and many other time-sensitive functions can be implemented scalably.



SDR++



Gqrx SDR



SoapySDR

7.

8.

**Internal M.2 2280 Slots**

Record as much as you want. At the time of ordering, an internal 2 TB card may be specified for use with your favorite recording applications. An additional slot is present for future capabilities.

**Power Management**

9.

**Managed Low Power States with Event-based Wakeup**

The new system controller and real-time clock (RTC) allow the Z4 to operate in several new power modes from sleeping while maintaining time keeping and state retention and consuming only a few mA, up to full system operation consuming 10–20 W from a 12 Vdc supply. Changing Low Power to Full Power states can be time-based, geo-location-based from the GPS, or event-based from the GPIO offering a high degree of flexibility. This might be useful in a UAS application, for example, where having the radio asleep until it reaches an area of interest would aid flight-time, or to leave the unit behind and have it wake up once per hour and survey.

**Micro Power**

- System Controller & RTC Powered by Coin Cell
- Enables Time Keeping & State Retention
- <6mA, <72mW on 12V DC Input

**Low Power**

- Enabled by Applying DC Power
- Micro Power State + GPS Rx & Ant. Bias
- System Controller Can Read NMEA Messages
- Full Power State Triggered by RTC, GPS, or GPIO
- <10mA, <120mW on 12V DC Input

**Full Power**

- Entire System is Powered: FPGA, RFICs, RF FE
- Power Consumption is Application Dependent
- Power consumption typically 10–20W on 12V DC Input

Interface Accessible	Micro Power Domain	Low Power Domain	Full Power Domain
Battery Voltage Query	✓	✓	✓
DC Input Detection	✓	✓	✓
LED Control	✓	✓	✓
External GPIO	✓	✓	✓
RTC	✓	✓	✓
GPS	✗	✓	✓
ZynqMP	✗	✗	✓
PL GPIO	✗	✗	✓

**Replaceable Coin Cell**

The Z4 has a user-accessible cover allowing field replacement of the CR1225 3V coin cell. The battery enables the system to maintain timekeeping and state retention while disconnected from the main power source.

**Easy Battery Operation**

With a wide 9 – 28 Vdc input range and low power consumption through use of the system controller modes, the Z4 is ideal for power-sensitive and battery-powered applications.

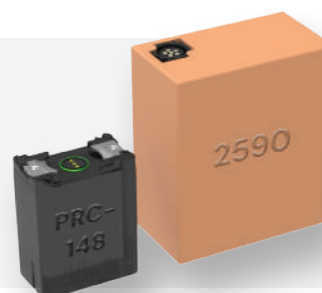

10.

## Developing With the Z4

We're told we're one of the easier companies to do business with, and that starts with the development experience which is designed to get you up and running fast.

1. It starts with the Platform Development Kit, or **PDK**, which contains a full development setup, including a Z4 unit, heat sink/ fan kit and cable kit. More details are given later.
2. The Z4 has been designed to give the utmost flexibility for designers needing to develop quickly, and uniquely allows you to **get closer to the hardware** if desired. This ranges from using a consistent set of commands to control the device, to developing software on the CPU, to controlling the RF hardware, to implementing custom FPGA code for the lowest latency processing. The Z4 has an open FPGA, open BSP, open kernel drivers, and open system controller
3. A **consistent software interface** is provided by Libsidekiq. Many SDRs are a combination of radio frequency (RF) components, one or more radio frequency integrated circuits (RFICs), and a variety of logic devices. This means controlling them requires expertise in very different domains. A typical RFIC will have more than 1,000 individual hardware registers that are often interdependent, so changing one affects several others, and they will be different in another RFIC.

Learning all of this and keeping up with it requires a consistent investment in time and money, which is why we developed **Libsidekiq** so that you don't have to.

Libsidekiq provides a layer of abstraction so that consistent commands may be applied independent of the radio model being controlled, and development effort leveraged between projects. It also comes with a reference design for the FPGA in use, which is coded with RF data pass-throughs out of the box, but may be customized by the user for time-sensitive applications.



*Libsidekiq Software Control  
for the Z4*

4. Libsideiq is compatible with a wide range of Epiq SDRs as shown in the list on the right. Code developed on one platform can be ported to others with the minimum of effort. It also comes with test examples to make starting development easier.
5. The Z4 uses the **same Libsideiq API as the Z2 and Z3u. Easily port** existing applications to the Z4 and update only the portions relating to the RF front end differences between the devices.
6. The PDK provides tools for the development of software for the target product. Once developed, it can **easily be deployed into production** on an unlimited number of production devices.
7. **Hardware warranty** is provided for 12 months from the date of delivery.
8. **Development support** is a big deal and something we have always taken very seriously. We don't subscribe to the model where support is abdicated to users helping each other. Instead, for verified purchasers of our products, we provide access to a private support forum. This gives access to our extensive collection of product literature including hardware, software and firmware development manuals. We won't write your code for you, but in our forum, questions that you ask will be addressed in a timely fashion, often by the engineers who designed the products you bought.

We also understand that projects are dynamic, and team members change, which is why questions that have been asked and answered for your project are archived forever; new people don't have to reinvent the wheel each time there's a change.

Forum access and software updates are included for three users for 12 months after purchase, and are optionally extendable.

### Support Forum Statistics 2023-25

- ~9,980 Total Posts by 557 Customers
- ~9,538 Total Responses by 46 Epiq Team Members
- Average of ~25 Forum Posts Per Working Day

### Customer Quote

*"Your staff who is manning the forums are 100% amazing. They have been very helpful and more responsive than every other support forum I've encountered."*

### Libsideiq Compatibility

Epiq SDRs Supported by Libsideiq:

- X40
- G20
- G40
- Z2
- Z3u
- M2
- MiniPCIe
- NV100
- NVM2
- Stretch
- VPX400
- X4
- **New Z4**

SDRs Not Supported by Libsideiq:

- Tuners e.g. VPX410
- VITA 49 streaming devices such as NV800, NDR Products

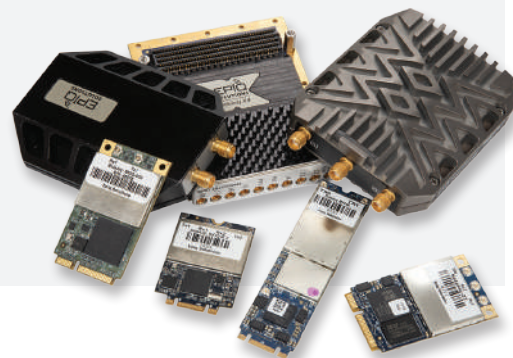

FORUM	TOPICS	POSTS	LAST POST
Getting Started	1	1	by admin Tue Dec 20, 2011 5:21 pm
<b>Epiq Solutions Support</b>			
Sideiq	191	283	by epiq-sdeng Mon Feb 05, 2024 12:14 pm
Sideiq M.2	28	29	by rhunter Mon Feb 05, 2024 12:16 pm
Sideiq NV100	17	17	by rhunter Mon Feb 05, 2024 12:43 pm
Sideiq NV800	7	7	by epiq-jwilliams Tue Jan 30, 2024 10:35 pm
Sideiq Stretch (M.2-2280)	25	25	by rhunter Mon Feb 05, 2024 12:28 pm
Sideiq VPX400	3	3	by epiq-barry Tue Dec 05, 2023 10:44 am
Sideiq VPX410	3	3	by epiq-barry Mon Nov 13, 2023 6:04 pm
Sideiq VPX425	0	0	No posts
Sideiq X2	33	33	by rhunter Thu May 11, 2023 3:30 pm
Sideiq X4	40	40	by rhunter Thu May 11, 2023 4:06 pm
Sideiq Z2	48	54	by epiq-dan Fri Feb 02, 2024 4:51 pm

## Capabilities

The following partner applications are suitable for use with the Z4.

### Distributed Spectrum **RF VISION**

[RF Vision](#) is a machine learning (ML) software platform that delivers RF situational awareness across diverse radio systems. Using Distributed Spectrum's specialized ML stack, it can identify, classify, and locate both known and unknown RF signals in real time.

The system supports automated alerts and responses, as well as open-standard formats for describing signal activity. RF Vision outputs can also be seamlessly integrated into ATAK and WinTAK environments to enhance operational awareness and decision-making.



### 3dB LABS **SCEPTRE**

#### Reveal The Unknown

**Quickly identify and locate anomalous signals across multiple domains.**

[Sceptre](#) provides state of the art signal processing software built for real-time and off-line spectrum and temporal analysis. Sceptre enables advanced signal discovery through remote spectrum operations, precision geo-location and multi-discipline analysis.

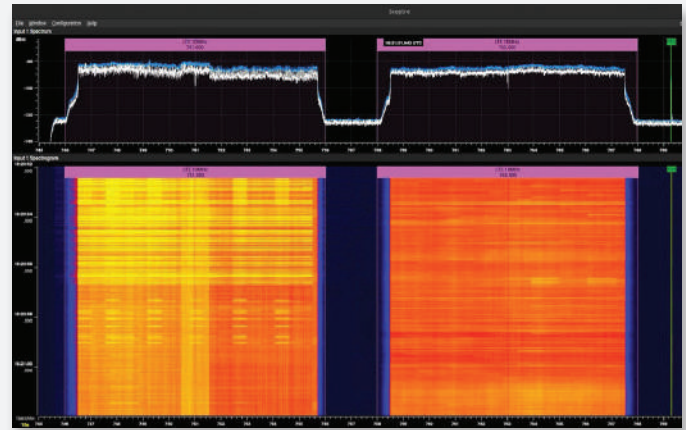

### EPIQ SKYLIGHT™

[Skylight™](#) is a software application that runs on Epiq's SDRs to provide low SWAP or high-performance cellular survey and wireless network characterization. Skylight™ is for anyone who needs to understand the wireless network environment around them.

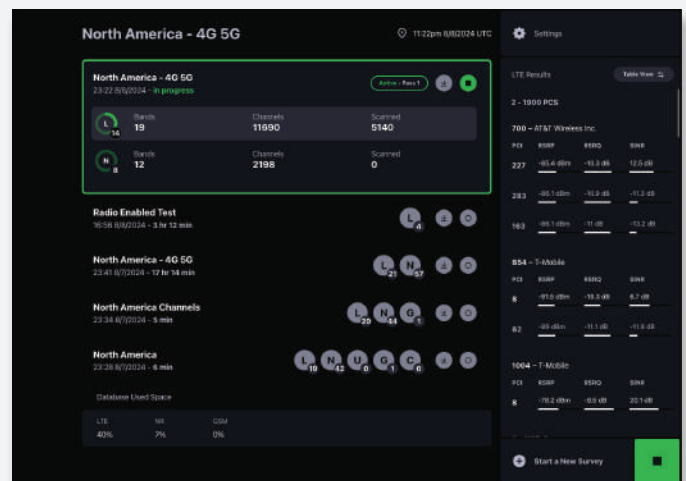

## Deployment Examples

### Example 1: Leave-Behind

The small size, weight and power (SWaP) and built-in host provide an excellent base for unattended survey applications, particularly when coupled with the system controller which enables time-based scheduling. With four RF ports which can be operated independently or phase-coherently, the Matchstiq Z4 also lends itself to search and DF applications.



### Example 2: UAS Payload

Weighing only 1.2 lb. (0.55 kg) and drawing 10 – 20 W when fully operational, the Matchstiq Z4 is ideally suited to payload applications. The system controller allows it to sleep while drawing minimal power and then come alive based on geo-fencing, time or GPIO triggers. Configuring the four RF ports to coherent transmit<sup>[1]</sup> will also open up the possibility of sophisticated decoy functionality.



[1] (Contact Epiq for availability)

### Example 3: Manpack/ Dismount

Another application where the low SWaP and sophisticated capture features come into their own is dismount. It has four independent search channels, the option of a large SSD for recording and later analysis, and snapshot mode for recording up to 1 second of full rate data.



### Other Examples

- Portable DF receiver
- Mesh Networks
- MIMO Communications
- SATCOM
- A-PNT Receiver
- Portable Spectrum Awareness
- Transmitter Decoy
- Arbitrary Waveform Generator
- RF-Enabled Cyber
- Test and Measurement

## The Epiq Family of Products





The X40 is part of our Platforms group of products that contain an accessible CPU which can run Linux or other operating systems and allow them to operate without a host.

The table below shows useful comparisons with:

- The **Z3u** as the Z4 is an updated, more capable but larger platform in the same range;
- The **G40** as it offers similar RF specifications but adds a GPU;
- The **NV800** which is a VITA 49 streaming radio aimed at survey and DF applications with more channels, for more size, weight and power.

The full range Epiq range is available in the comparison table [here](#).



Product	<a href="#">Matchstiq Z4</a>	<a href="#">Matchstiq Z3u</a>	<a href="#">Matchstiq G40</a>	<a href="#">Sideiq NV800</a>
				
<b>Description</b>	4 channel 6 GHz SDR with CPU	Small, packaged 6 GHz SDR with CPU	SWaP-optimized GPU-equipped SDR	8 channel 6 GHz VITA 49 streaming SDR
<b>Output</b>	Digital			
<b>Max Channels Rx/ Tx</b>	4/ 4	2/ 1	4/ 4	8/ 1
<b>Frequency Range</b>	10 MHz - 6 GHz	45 MHz - 6 GHz	10 MHz - 6 GHz	
<b>IBW Max/ Ch.</b>	50 MHz			
<b>SFDR Typ.</b>	70 dB	60 dB	75 dB	
<b>CPU?</b>	Yes			-
<b>GPU?</b>	-		Yes	-
<b>Typ. Power Consumption</b>	10 - 20 W	4.5 W	30 W	25 W
<b>Interface e.g.</b>	USB	USB	Ethernet & USB	Eth., VITA 49 Streaming

Maximum number of Rx, Tx channels, often not simultaneously. SFDR = Spurious Free Dynamic Range. IBW = Instantaneous Bandwidth. Interface example, often others present also.

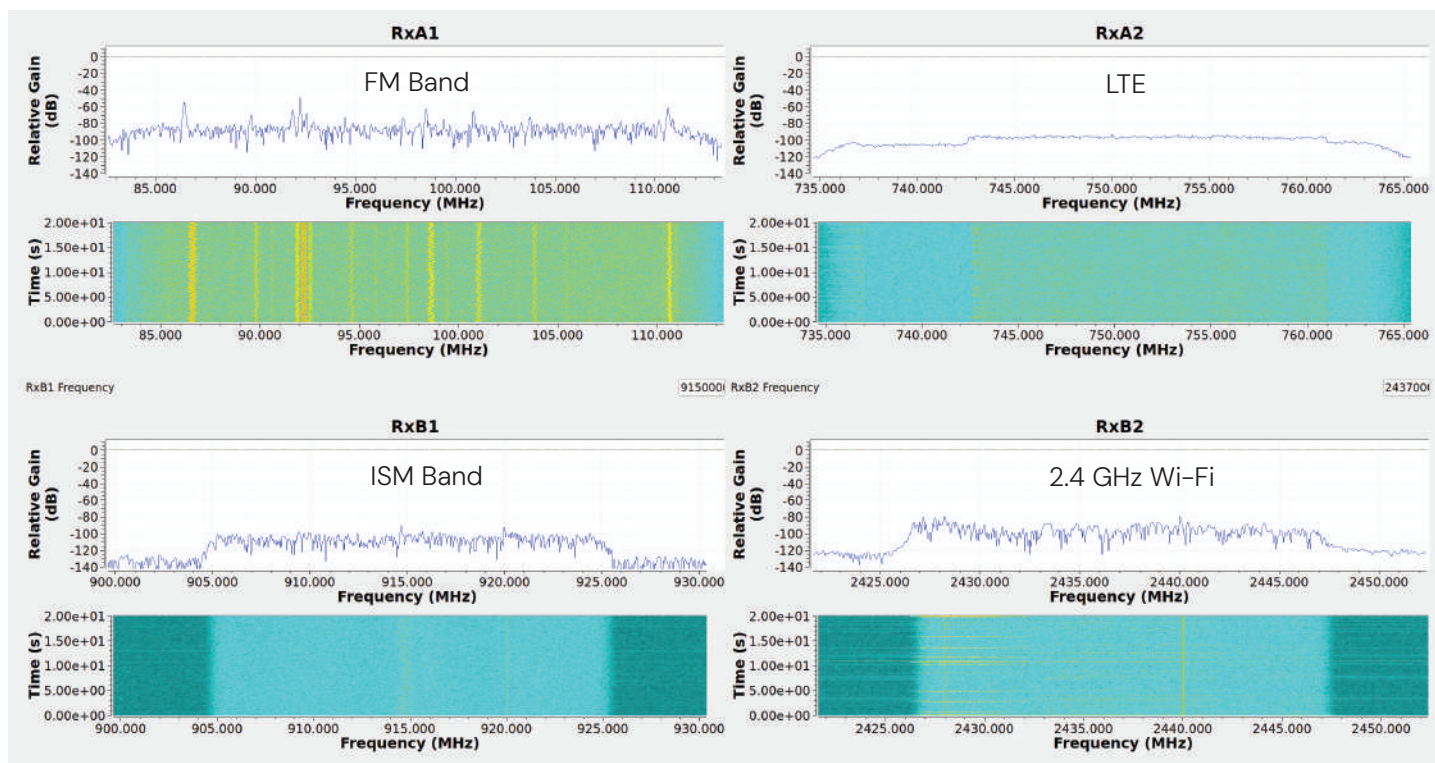

GNU Radio running on the Z4 performing monitoring of four different frequency bands of interest.



The Matchstiq **Z3u** has become a trusted workhorse with a loyal following. The **Z4** takes performance to a new size and level, and has:

- Twin ADRV9004 RFICs compared to a single AD9361; this produces a 16-bit vs. 12-bit radio enabling higher linearity and dynamic range as well as four channels vs. two.
- ZU7 vs. ZU3 FPGA, giving notably more programmable logic (PL) and higher speed I/O.
- Addition of a system controller for sophisticated power management options.
- Significant on-board storage and room for future expansion.

## Z4 Physical Views

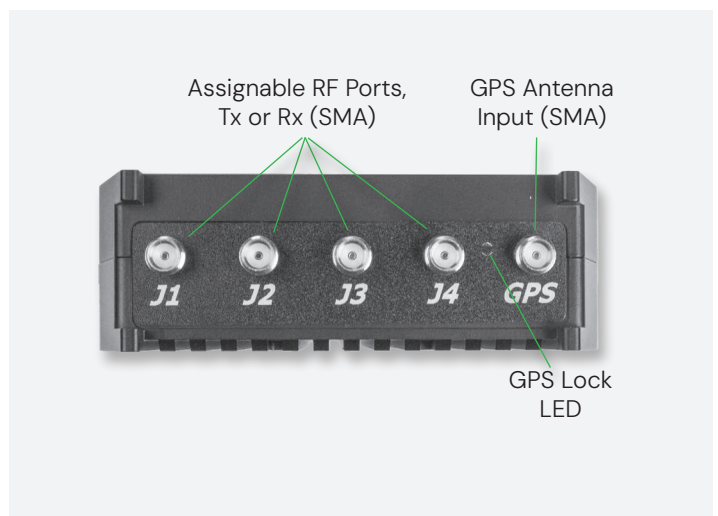
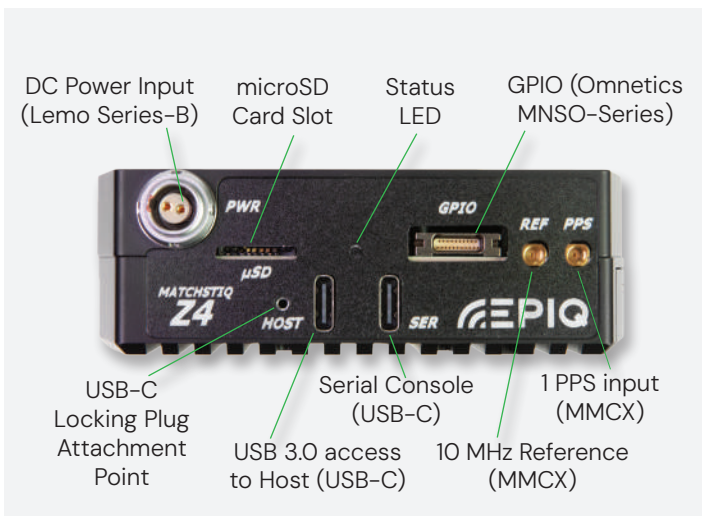
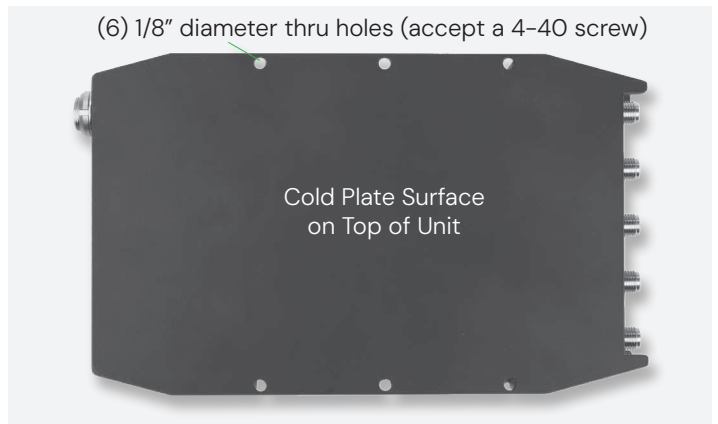
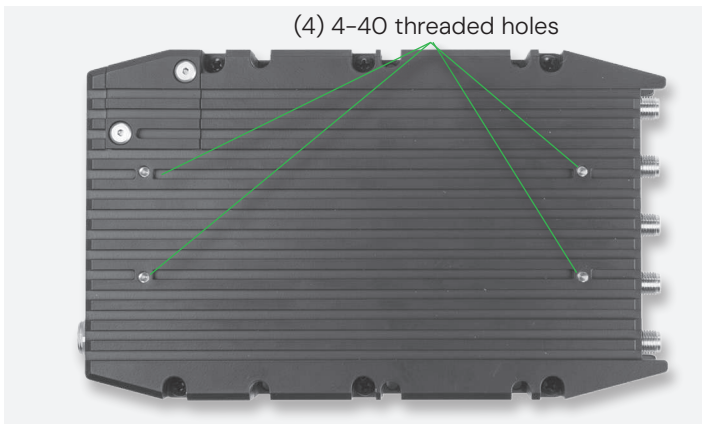
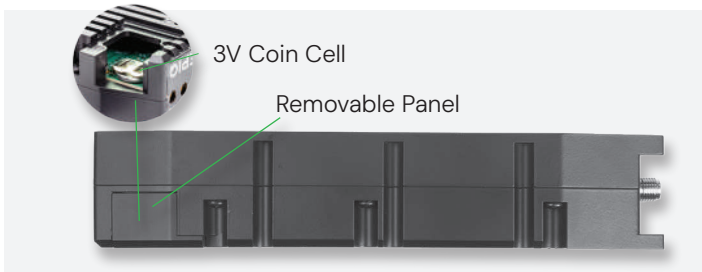

## Optional Accessories

Note that Z4 units are shipped with no accessories unless ordered in addition.

### PDK Kit

The Platform Development Kit contains the following hardware:

- Z4 unit with option to be supplied with and without 2 TB SSD card
- Fan/ Heatsink kit
- Cable kit

(More details on kits in following pages)

### Z4 Unit & Fan/ Heatsink Kit



(Fan unit may be powered from the Z4 USB-C, if desired)

### Z4 Cable Kit



Power Brick &  
120V Standard  
Cable

GPIO  
Pigtail

Power  
Pigtail

### Battery Cables

Two different adapter cables are also orderable:

- Z4 power connector to PRC-148 (~30", 0.75 m)
- Z4 power connector to 2590 (~30", 0.75 m)

(Renderings shown, batteries not included)



## Z4 Fan/ Heatsink Kit

The kit includes the fan/ heatsink unit, USB-C cable, mounting hardware kit and instructions.



(Z4 units shown for context, not included in kit)



(1) 6" (~150 mm) USB-C Fan Power Cable & (6) 4-40 mounting screws



## Matchstiq Z4 Cable Kit

This kit contains the non-RF cables required including GPIO pigtail, power pigtail and the power brick with 120V power cable.

### GPIO Pigtail

Pigtail



View of GPIO mating connectors



Pigtail connected to example Z4 unit



### Power Brick with 120V Power Cable

Brick and Standard 120V Cable



Brick connected to example Z4 unit



### Power Pigtail

Pigtail connected to example Z4 unit



Pigtail



View of mating power connectors





*Specifications subject to change without notice.*

*Epiq Solutions exports its products strictly in accordance with all US Export Control laws and regulations which shall apply to any purchase or order.*

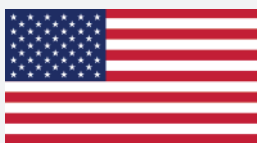

## **ABOUT EPIQ**

Epiq Solutions develops high performance tools for engineering teams and government-focused organizations requiring situational awareness and detailed insight into their RF environments in order to identify and act against wireless threats.

31st January, 2026