

HIOKI

RESISTANCE METER RM3542C

NEW



Measure Faster, Judge Smarter

Automation and quality assurance for the next generation of production testing



3 year
Warranty

ES France - Département Tests & Mesures
127 rue de Buzenval BP 26 - 92380 Garches

Tél. 01 47 95 99 45

e-mail : tem@es-france.com
Site Web : www.es-france.com

Proven Foundation

Trusted by production lines worldwide, delivering stable, stress-free, and reliable measurement

RESISTANCE METER RM3542C



Speed—Fast, Accurate, and Flexible

High-speed, high-accuracy testing

Customize Integration Time

- Set the integration time for each measurement range to meet your specific production needs.
- Short integration time: maximize takt time and throughput on production lines.
- Long integration time: ensure stability and repeatability for final inspection or high-precision applications.

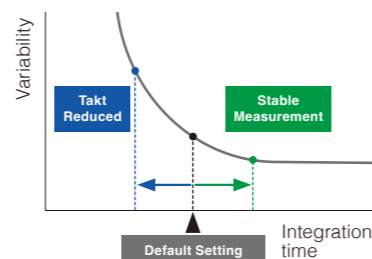

Range	Low power: off		
	Integration Time		
	Fast	Med.	Slow
100 mΩ	0.5 ms	5.0 ms	1 PLC
1000 mΩ	0.3 ms	2.5 ms	1 PLC
100 kΩ	0.5 ms	3.0 ms	1 PLC
1000 kΩ	1.5 ms	5.0 ms	1 PLC

Stability—Consistent Results in Every Environment

Stable and repeatable measurements, even in noisy production environments

Optimized Intermediate Ranges

Intermediate ranges (e.g., 3, 300 Ω) boost S/N ratio, cut variation, and ensure repeatable results—even in noisy lines.

- Achieve Stable Measurements in a Wide Measurement Range

Intermediate range

Range	Measurement current
100 mΩ	100 mA
1000 mΩ	100 mA
3 Ω	33.3 mA
10 Ω	10 mA
100 Ω	10 mA
300 Ω	3.33 mA
1000 Ω	1 mA
10 kΩ	1 mA
30 kΩ	333 μA
100 kΩ	100 μA
300 kΩ	33.3 μA
1000 kΩ	10 μA
3 MΩ	3.33 μA
10 MΩ	1 μA
30 MΩ	333 nA
100 MΩ	100 nA

150 Ω Measurement Comparison

Example of reduced variation with the improved range
Comparison data with the same sample

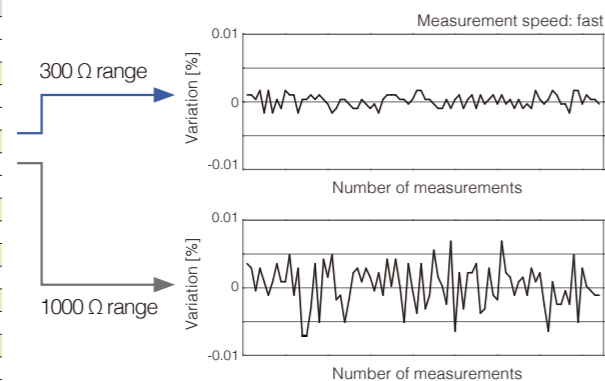

Noise-Resistant Galvanically Isolated Structure

Galvanically Isolated architecture minimizes the effect of external electrical interference. This ensures reliable data even in production lines with high noise levels.

Compliant with **EN61326 Class A** for industrial environments.

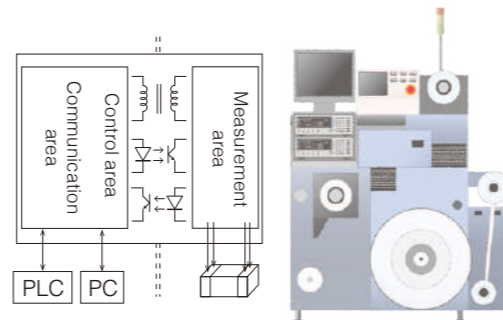

Reliability—Confidence in Every Measurement

Engineered to protect sensitive components and guarantee stable, trustworthy contact for consistent, accurate results

Safe, Stress-Free Testing for Micro-Components

The applied voltage limiter prevents damage by limiting applied voltage to 5 V or less, enabling safe and accurate testing of micro-components such as 008004 size resistors.

Applied Voltage Limit Function: On

Object under test	Measurement current	Applied voltage
1 kΩ	1 mA	1 V
2 kΩ		2 V
3 kΩ		3 V
4 kΩ		4 V
5 kΩ		5 V
6 kΩ	333 μA	2 V
7 kΩ		2.3 V
8 kΩ		2.6 V
9 kΩ		3 V
10 kΩ		3.3 V

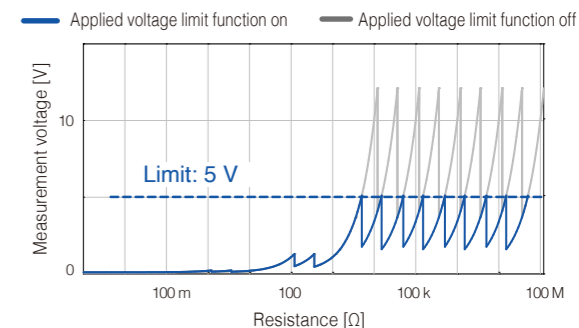

Optimized Probe Contact

Contact Improvement delivers stable probe contact by penetrating oxidation and impurities between probes and DUT, stabilizing measurements and reducing contact error rate. This leads to fewer re-measurements and higher productivity.

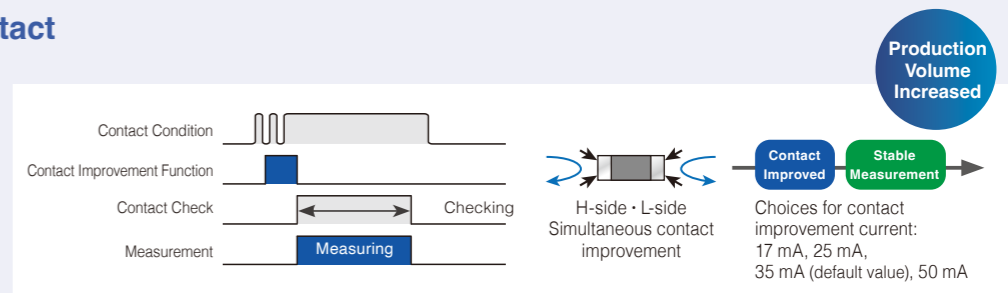

Configurable Contact Improvement Settings

By applying Contact Improvement sequentially to the H and L sides, inrush current is suppressed—preventing characteristics shifts in sensitive parts like ferrite beads.

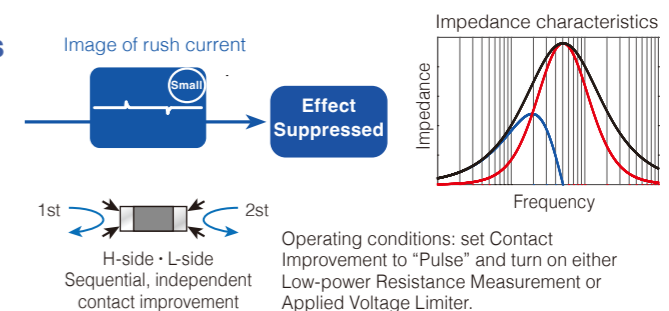

Contact Error Detection & Automatic Correction

Contact & anomaly monitoring: the instrument continuously monitors contact conditions during measurement.

- Contact Check** detects probe chatter by monitoring changes in contact resistance.
- Voltage Monitor** checks for changes in measured voltage caused by current terminal contact resistance shifts or mechanical noise.

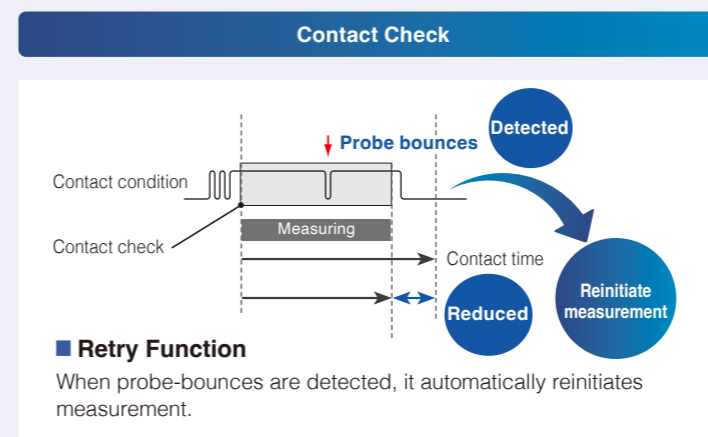

Retry Function

When probe-bounces are detected, it automatically reinitiates measurement.

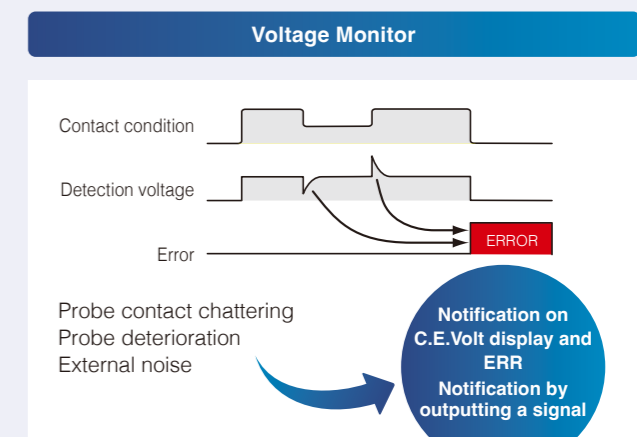

Three Benefits for Smart Testing

Three Innovations That Increase Throughput and Ensure Reliable Testing Results

1. Shorten jumper resistor inspection time by up to 76 %
2. Improve grading and sorting efficiency
3. Increase inspection reliability and overall taping machine efficiency

These three advanced capabilities enhance production efficiency and deliver stable, repeatable measurement quality—even under demanding line conditions.

1 Shorten jumper resistor inspection time by up to 76 % RM3542C-1 RM3542C-2 RM3542C-3

Jumper Resistance Measurement Support Function (Jumper Mode)

This is a feature that speeds up production testing for very low-resistance components, like zero-ohm resistors (jumpers). Normally, testing a component below 100 mΩ requires a long measurement time to ensure ultra-high accuracy. Because this delay can slow down your overall production speed (takt time), Jumper Mode skips the slower, high-accuracy measurement ranges at or below 100 mΩ. This lets you perform a quick, reliable "pass/fail" judgment on jumper resistors, keeping your production throughput high.

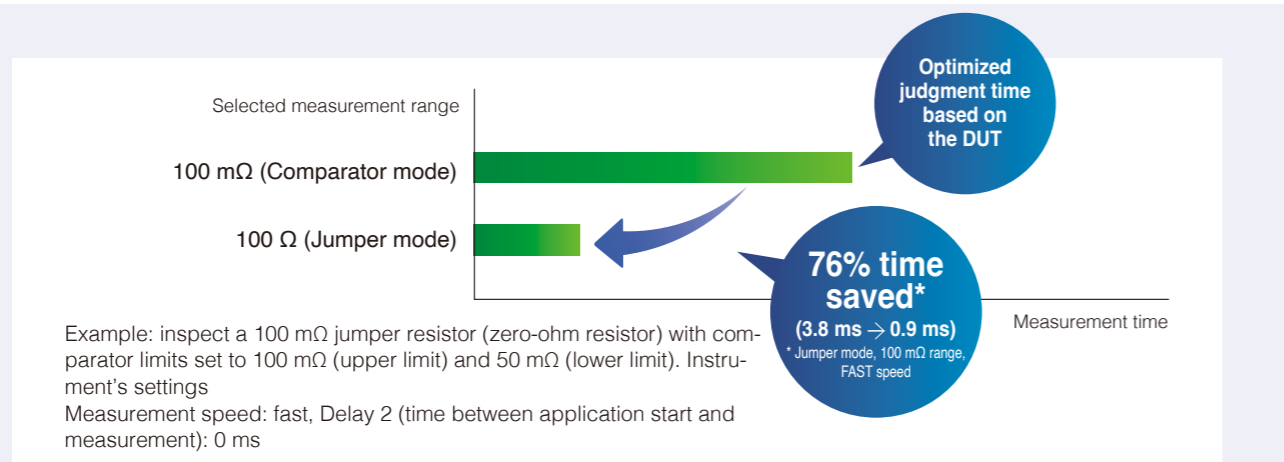

Jumper mode: off

The upper-limit setting automatically selects the 100 mΩ measurement range, with OVC enabled by default.

Measurement time
= (integration time + internal delay + Delay 2) × OVC = (0.5 ms + 1.4 ms + 0 ms) × 2 = 3.8 ms*
Accuracy
±0.023 mΩ

Jumper mode: on

In Jumper mode, the lower limit is 100 Ω, and the instrument selects the 100 Ω range with OVC turned off by default.

Measurement time
= (integration time + internal delay + Delay 2) × OVC* = (0.3 ms + 0.6 ms + 0 ms) × 1 = 0.9 ms*
Accuracy
± 0.0030 Ω ± 3.0 mΩ in 100 Ω range (sufficient for jumper pass/fail)

* OVC multiplier:
on = × 2, off = × 1

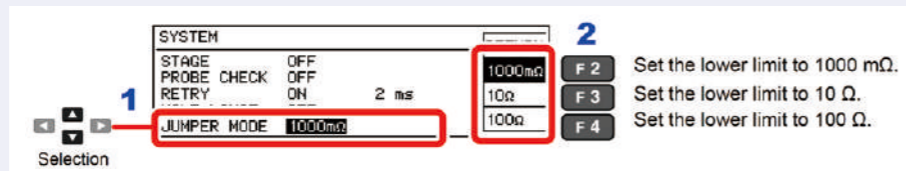

2 Improve grading and sorting efficiency RM3542C-3

Integrated BIN Measurement Function

Eliminates the complexity and delay of host-system-based grading. The automated function performs judgment and grading inside the instrument and outputs the result directly via I/O. This reduces system workload and response time, and improves efficiency on production lines with strict takt time requirements.

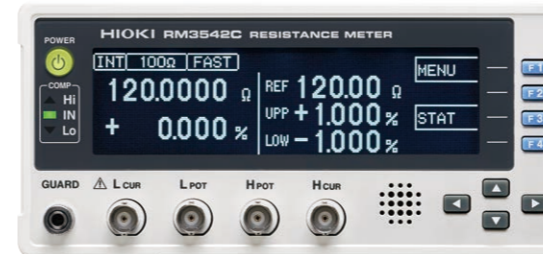

Select and grade measurement targets using multiple criteria

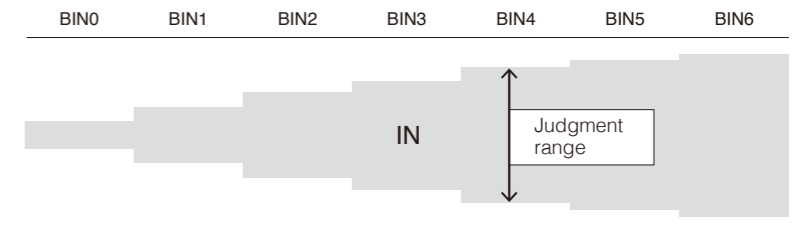

The upper and lower limits for each BIN are set as relative values (%) based on a reference value, enabling classification into a maximum of 7 ranks. Measurement results that do not fall into any BIN are judged as OB (Out of BIN). The judgment result can also be output via the EXT I/O.
(The upper and lower limits are set using communication commands.)

3 Increase inspection reliability and overall taping machine efficiency RM3542C-3

ΔR Function

This function compares measurement results from two stages (on one or between separate instruments). For high-reliability chip resistor testing, resistance values must not only fall within target ranges before and after rated voltage stress application but must also remain within a specified percentage difference. This cross-stage auto-judgment automatically compares measurement results from two separate instruments and flags defects when the difference exceeds a threshold. This strengthens inspection reliability and reduces system workload by eliminating complex cross-checks.

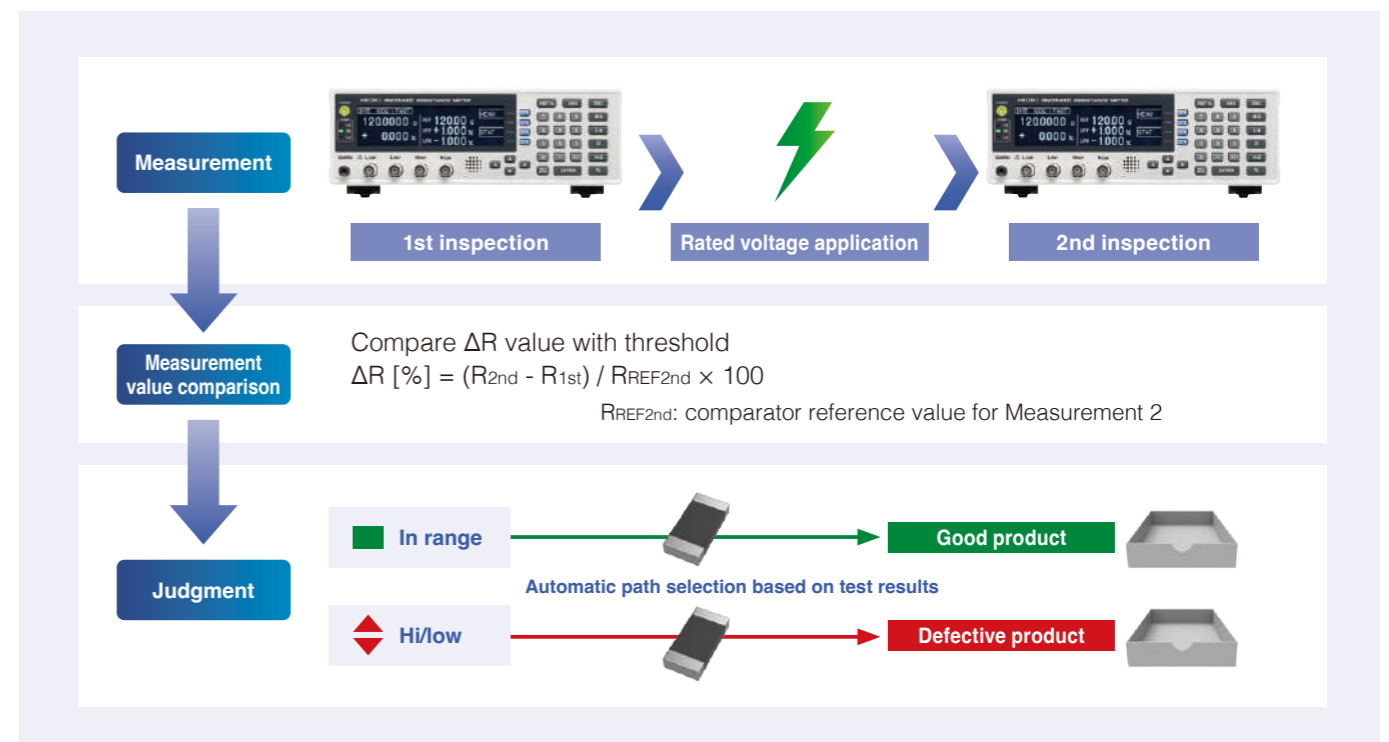

Smart Functions for Enhanced Precision

Additional features strengthen precision and reliability
 –delivering stricter inspection, consistent accuracy,
 and reduced human error in daily operation.

Fast, error-free changeover and consistent quality across production lines

RM3542C-1 RM3542C-2 RM3542C-3

Preset Function

Saves and recalls a single measurement setup in the instrument. This reduces changeover time, prevents operator setting errors, and ensures consistent measurement conditions for multi-product production lines.

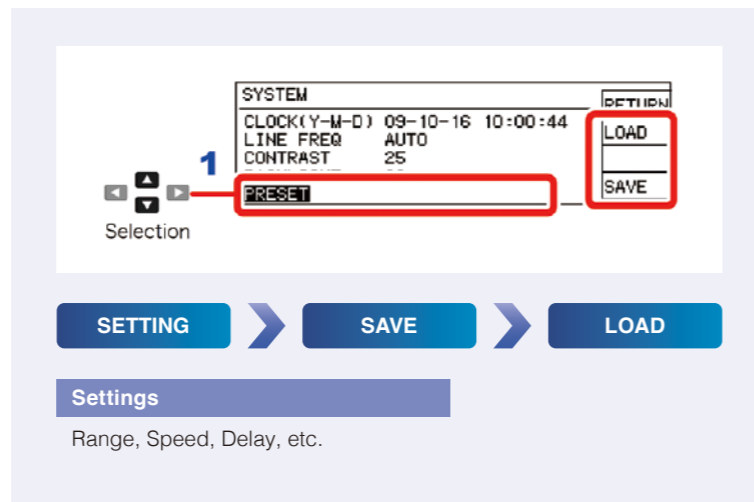

Reduced risk of human error during calibration and maintenance

RM3542C-1 RM3542C-2 RM3542C-3

Stage Mismatch Prevention Function

/EOM outputs on Pin-14 (Stage 1) or Pin-28 (Stage 2)—instantly flagging miswiring. By assigning separate outputs for each stage, operators can quickly detect equipment installation errors after calibration or maintenance. This is especially useful when two instruments are installed on automated equipment. It prevents wrong-stage operation and ensures the production line resumes correctly.

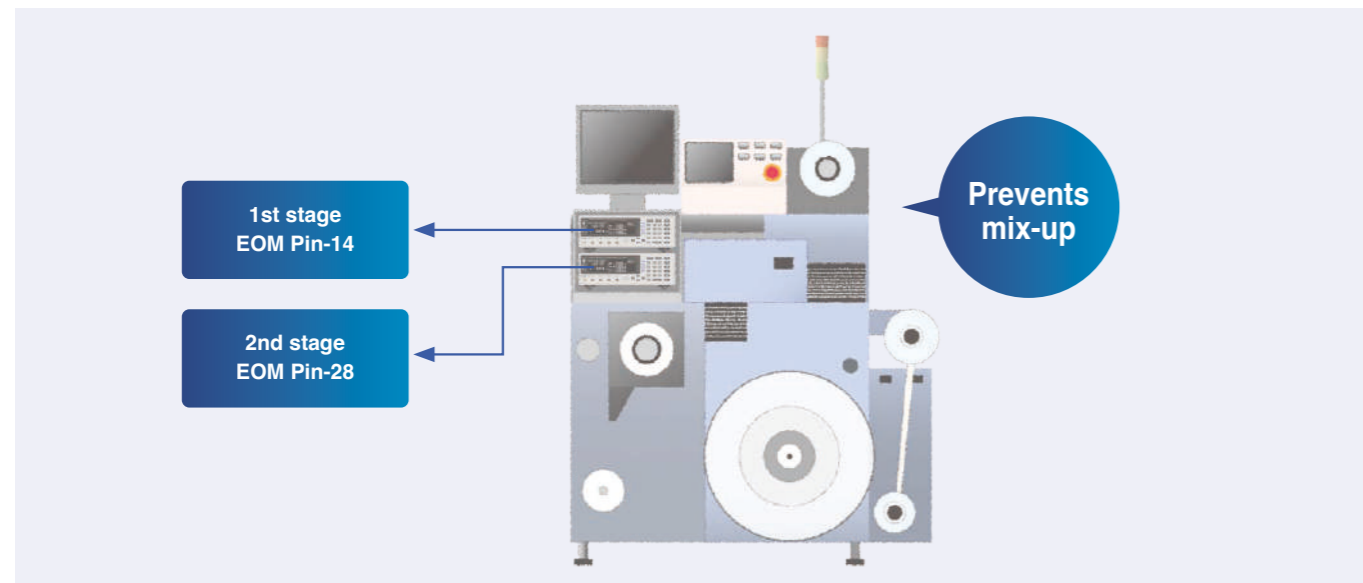

High-precision accuracy for tight-tolerance inspection

RM3542C-3

90-day Guaranteed Accuracy

Unlike conventional one-year accuracy specifications, this instrument guarantees measurement accuracy over a shorter 90-day period. By limiting the guarantee period, it achieves a higher accuracy specification, enabling reliable inspection of components with very narrow tolerance ranges even in high-volume production lines.

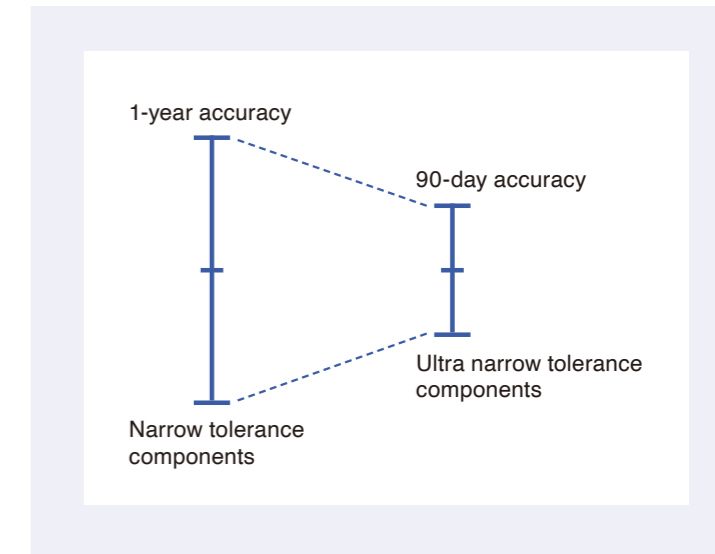

Efficient data management and enhanced traceability

Simplify data management and improve traceability with features that automatically capture, store, and output stable measurement data.



Data Storage Function

Saving to internal memory via trigger signal or key operation

- Up to 30,000 measurement events are automatically saved to internal memory on every valid trigger:
- External trigger (EXT I/O or command)
- Internal periodic trigger (1 ms to 99.999 s interval)
- Manual trigger (TRIG key)

Auto-Memory Function

Auto-save/auto-print of stable measurement values (Individually selectable)

When the Sampling Measurement Mode is set, the RM3542C-3 automatically saves 2–99 stable measurement values upon probe contact, then stops and displays statistical calculations (max/min/avg/σ/Cp/Cpk). If a printer is connected via RS-232C, it can also auto-print the statistical report.

Printing example (Normal mode)

7	219.701	Ohm	IN
8	220.031	Ohm	IN
9	220.687	Ohm	IN
10	150.119	Ohm	Lo
11	330.065	Ohm	Hi
12	OvrRng	Hi	
13	C.E.Lo	--	
14	C.E.Hi	--	

Printing example (Sample mode: fixed-count statistical report)

-0.136%/IN	+0.014%/IN	+0.312%/IN
-31.764%/Lo	+50.030%/Hi	+999.999%/Hi
MEAS.ERR/--	MEAS.ERR/--	

3 sets of data are printed on 1 line to save paper.

Preset Function

Operation	SAVE Saves the instrument's settings to the reserved area. Load applies the settings saved in the reserved area to the instrument.
-----------	--

Stage Mismatch Prevention Function

Operation	To prevent use of the wrong stage, a stage number is assigned to the resistance meter. The output pin of the EXT. I/O EOM signal varies depending on the stage number setting. off, STG2nd :28 pin STG1st :14 pin
Setting	OFF/ STG1st/ STG2nd

GP-IB (RM3542C-2)

Connector	24-pin Centronics type connector
Compliance standard	IEEE-488.1 1987
Reference standard	IEEE-488.2 1987
Terminator	LF, CR+LF

Recording/Interface

Memory storage	Measurement values are recorded by the EXT.I/O TRIG signal and F4 [MANU] button.
	Number of memory slots: 30000 (volatile memory, no backup) Statistical Calculation Functions: Statistical calculations are performed for measurement values saved to memory. (Calculation contents: Total data count, average value, minimum value, maximum value, sample standard deviation, population standard deviation, process capability index) Calculation results: Displayed on screen/printed
Auto-memory function	Loading when measured value is stable, with manual measurement by internal continuous trigger (A beeping sound is heard if the specified value is reached.) Memory slots: 1 to 99
Interface	EXT.I/O, RS-232C, Printer, Settings Monitor Function terminals (SET MONITOR terminals), GP-IB (RM3542C-2 only)

Measurement Specifications

Conditions of guaranteed accuracy

Warm-up time	30 minutes or more for 1-year accuracy 60 minutes or more for 90-day accuracy (RM3542C-3)
Integration time	Longer than the default value for the Integration Time Setting Function (No regulation for settings in ms if the default value is set to PLC)
Temperature and humidity range for guaranteed accuracy	23°C ±5°C (73°F ±9°F), 80% RH or less

Temperature fluctuation after self-calibration must be within ±2°C (±3.6°F). Add Temperature Coefficient ±(1/10 of measurement accuracy)/°C for the following ranges: 0°C to 18°C (32°F to 64°F) and 28°C to 40°C (82°F to 104°F).

1-year accuracy (LOW POWER: OFF)

Range	Maximum display value *1	Resolution	Measurement accuracy: ±(%rdg + %f.s.)			Measurement current *2	Open-circuit voltage
			Fast	Med.	Slow *3		
10 mΩ *7	12.00000 mΩ	10 nΩ	0.015 + 0.080	0.015 + 0.030	0.015 + 0.010*6 0.015 + 0.020	100 mA	20 Vmax *3*4*5
100 mΩ	120.0000 mΩ	100 nΩ	0.015 + 0.008	0.015 + 0.003	0.015 + 0.002	100 mA	
1000 mΩ	1200.000 mΩ	1 μΩ	0.012 + 0.003	0.012 + 0.002	0.012 + 0.001	100 mA	
3 Ω *8	3.60000 Ω	10 μΩ	0.012 + 0.003	0.012 + 0.002	0.012 + 0.001	33.3 mA	
10 Ω	12.00000 Ω	10 μΩ	0.012 + 0.003	0.008 + 0.002	0.008 + 0.001	10 mA	
100 Ω	120.0000 Ω	100 μΩ	0.009 + 0.003	0.007 + 0.002	0.007 + 0.001	10 mA	
300 Ω *8	360.000 Ω	1 mΩ	0.009 + 0.003	0.007 + 0.002	0.007 + 0.001	3.33 mA	
1000 Ω	1200.000 Ω	1 mΩ	0.009 + 0.003	0.007 + 0.002	0.006 + 0.001	1 mA	
10 kΩ	12.00000 kΩ	10 mΩ	0.009 + 0.003	0.007 + 0.002	0.006 + 0.001	1 mA	
30 kΩ *8	36.0000 kΩ	100 mΩ	0.009 + 0.003	0.007 + 0.002	0.007 + 0.001	333 μA	
100 kΩ	120.0000 kΩ	100 mΩ	0.010 + 0.003	0.007 + 0.002	0.007 + 0.001	100 μA	
300 kΩ *8	360.000 kΩ	1 Ω	0.010 + 0.003	0.007 + 0.002	0.008 + 0.001	33.3 μA	
1000 kΩ	1200.000 kΩ	1 Ω	0.010 + 0.003	0.008 + 0.002	0.008 + 0.001	10 μA	
3 MΩ *8	3.60000 MΩ	10 Ω	0.010 + 0.003	0.008 + 0.002	0.008 + 0.001	3.33 μA	
10 MΩ	12.00000 MΩ	10 Ω	0.030 + 0.004			1 μA	
30 MΩ *8	36.0000 MΩ	100 Ω	0.030 + 0.010			333 nA	
100 MΩ	120.0000 MΩ	100 Ω	0.100 + 0.020			100 nA	

1-year accuracy (LOWER: ON)

Range	Maximum display value *1	Resolution	Measurement accuracy: ±(%rdg + %f.s.)			Measurement current *2	Open-circuit voltage
			Fast	Med.	Slow *3		
1000 mΩ	1200.000 mΩ	1 μΩ	0.010 + 0.008	0.008 + 0.003	0.008 + 0.002	10 mA	10 Vmax *3*5
3 Ω *8	3.60000 Ω	10 μΩ	0.010 + 0.008	0.008 + 0.003	0.008 + 0.002	3.33 mA	
10 Ω	12.00000 Ω	10 μΩ	0.010 + 0.008	0.008 + 0.003	0.008 + 0.002	1 mA	
100 Ω	120.0000 Ω	100 μΩ	0.010 + 0.003	0.008 + 0.002	0.008 + 0.001	1 mA	
300 Ω *8	360.000 Ω	1 mΩ	0.010 + 0.003	0.008 + 0.002	0.008 + 0.001	333 μA	
1000 Ω	1200.000 Ω	1 mΩ	0.020 + 0.003	0.008 + 0.002	0.008 + 0.001	100 μA	

*1. Negative values can be up to 10% of positive full scale.
 *2. Measurement current accuracy is ±5%.
 *3. 20 mV or less when not measuring, with Pulse current mode and Contact Improvement set to OFF or Pulse (by 10 MΩ input-impedance voltmeter)
 *4. When VOLTAGE LIMIT is set to ON: 10 V max.
 *5. The total of the allowable measurement probe, measurement target, and contact resistance will be less than the resistance value calculated by dividing the no-load voltage by the measurement current. Example: For a measurement current of 100 mA, measurements can be made under conditions such that the total of the measurement probe, measurement target, and contact resistance does not exceed 20 Ω.
 *6. When the average function is ON and the average count is set to 16 or greater. Specified only for 10 mΩ range SLOW operation; otherwise, does not depend on the average setting. (RM3542C-3)
 *7. RM3542C-3
 *8. RM3542C-1, RM3542C-2 or RM3542C-3

90-day accuracy (Low power: off)

Range	Maximum display value *1	Resolution	Measurement accuracy: ±(%rdg + %f.s.)			Measurement current *2	Open-circuit voltage
			Fast	Med.	Slow *3		
10 mΩ	12.00000 mΩ	10 nΩ	0.015 + 0.080	0.015 + 0.030	0.012 + 0.010 *6 0.012 + 0.020	100 mA	20 Vmax *3*4*5
100 mΩ	120.0000 mΩ	100 nΩ	0.015 + 0.008	0.015 + 0.003	0.012 + 0.002	100 mA	
1000 mΩ	1200.000 mΩ	1 μΩ	0.012 + 0.003	0.012 + 0.002	0.011 + 0.001	100 mA	
3 Ω	3.60000 Ω	10 μΩ	0.012 + 0.003	0.012 + 0.002	0.011 + 0.001	33.3 mA	
10 Ω	12.00000 Ω	10 μΩ	0.010 + 0.003	0.008 + 0.002	0.007 + 0.001	10 mA	
100 Ω	120.0000 Ω	100 μΩ	0.009 + 0.003	0.007 + 0.002	0.005 + 0.001	10 mA	
300 Ω	360.000 Ω	1 mΩ	0.009 + 0.003	0.007 + 0.002	0.005 + 0.001	3.33 mA	
1000 Ω	1200.000 Ω	1 mΩ	0.008 + 0.003	0.006 + 0.002	0.005 + 0.001	1 mA	
10 kΩ	12.00000 kΩ	10 mΩ	0.009 + 0.003	0.007 + 0.002	0.006 + 0.001	1 mA	
30 kΩ	36.0000 kΩ	100 mΩ	0.009 + 0.003	0.007 + 0.002	0.006 + 0.001	333 μA	
100 kΩ	120.0000 kΩ	100 mΩ	0.010 + 0.003	0.007 + 0.002	0.006 + 0.001	100 μA	
300 kΩ	360.000 kΩ	1 Ω	0.010 + 0.003	0.007 + 0.002	0.006 + 0.001	33.3 μA	
1000 kΩ	1200.000 kΩ	1 Ω	0.010 + 0.003	0.008 + 0.002	0.007 + 0.001	10 μA	
3 MΩ	3.60000 MΩ	10 Ω	0.010 + 0.003	0.008 + 0.002	0.007 + 0.001	3.33 μA	
10 MΩ	12.00000 MΩ	10 Ω	0.030 + 0.004			1 μA	
30 MΩ	36.0000 MΩ	100 Ω	0.030 + 0.010			333 nA	
100 MΩ	120.0000 MΩ	100 Ω	0.100 + 0.020			100 nA	

90-day accuracy (Low power: on)

Range	Maximum display value*1	Resolution	Measurement accuracy: ±(%rdg + %f.s.)			Measurement current *2	Open-circuit voltage
			Fast	Med.	Slow *3		
1000 mΩ	1200.000 mΩ	1 μΩ	0.010 + 0.008	0.008 + 0.003	0.008 + 0.002	10 mA	10 Vmax *3*5
3 Ω *8	3.60000 Ω	10 μΩ	0.010 + 0.008	0.008 + 0.003	0.008 + 0.002	3.33 mA	
10 Ω	12.00000 Ω	10 μΩ	0.010 + 0.008	0.008 + 0.003	0.008 + 0.002	1 mA	
100 Ω	120.0000 Ω	100 μΩ	0.010 + 0.003	0.008 + 0.002	0.008 + 0.001	1 mA	
300 Ω	360.000 Ω	1 mΩ	0.010 + 0.003	0.008 + 0.002	0.008 + 0.001	333 μA	
1000 Ω	1200.000 Ω	1 mΩ	0.020 + 0.003	0.008 + 0.002	0.008 + 0.001	100 μA	

*1. Negative values can be up to 10% of positive full scale.
 *2. Measurement current accuracy is ±5%.
 *3. 20 mV or less when not measuring, with pulse current mode and contact improvement set to off or pulse (by 10 MΩ input-impedance voltmeter)
 *4. When VOLTAGE LIMIT is set to ON: 10 V max.
 *5. The total of the allowable measurement probe, measurement target, and contact resistance will be less than the resistance value calculated by dividing the no-load voltage by the measurement current. Example: For a measurement current of 100 mA, measurements can be made under conditions such that the total of the measurement probe, measurement target, and contact resistance does not exceed 20 Ω.
 *6. When the average function is ON and the average count is set to 16 or greater. Specified only for 10 mΩ range SLOW operation; otherwise, does not depend on the average setting.
 *7. RM3542C-3
 *8. RM3542C-1, RM3542C-2, RM3542C-3

Dimensions (units: mm)

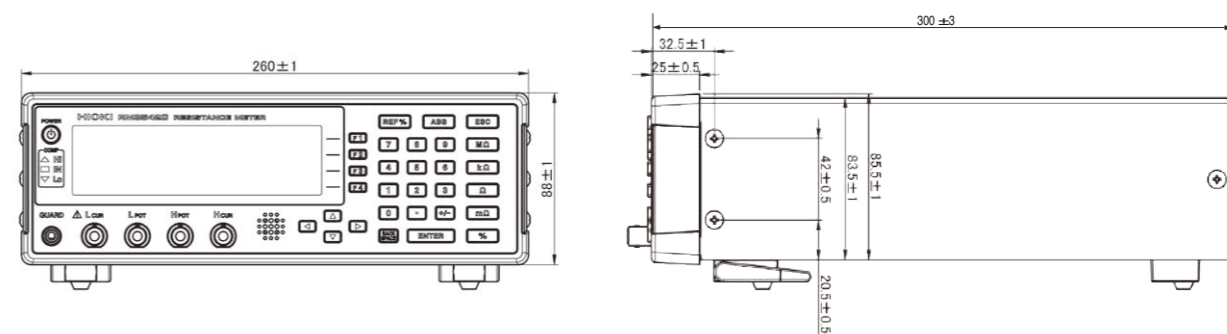

Recommended Model for Each Type of Measurement

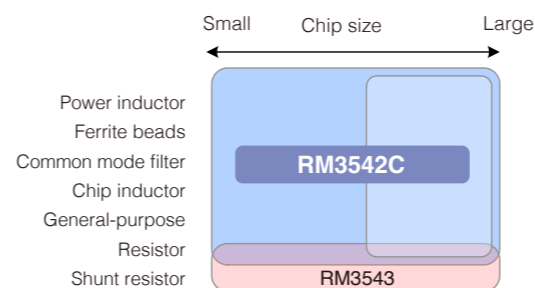

RESISTANCE METER RM3542C



Model No. (order code)	GP-IB interface
RM3542C-1	Not supported
RM3542C-2	Supported
RM3542C-3	Not supported

Options

Probes and Fixtures (for connection to measurement terminals)



FOUR-TERMINAL PROBE 9140-10
(for RM3542C)
For test leaded parts
Diameter of supported measurement terminals: 0.3 to 5 mm (0.01 to 0.20 in.)
Cable length: 1 m (3.28 ft.)



TEST FIXTURE 9262
For test leaded parts
Diameter of supported measurement terminals: 0.3 to 2 mm (0.01 to 0.08 in.)
Pitch of test lead: 5 mm (0.20 in.) or greater
Connects directly to main unit



SMD TEST FIXTURE 9263
For SMD with electrodes on the sides
Supported sample sizes: 2012 to 5750 (JIS)
0805 to 2220 (EIA)
Sample width: 1 to 10 mm (0.04 to 0.39 in.)
Connects directly to main unit



SMD TEST FIXTURE IM9100
For SMD with electrodes on the bottom
Supported sample sizes: 0402 to 1005 (JIS)
01005 to 0402 (EIA)
Connects directly to main unit

See the product catalogs for details.

Recommended Measurement Cable Specifications

Conductor resistance	500 mΩ/m or less
Capacitance	150 pF/m or less
Cable dielectric material	Polyethylene (PE), Teflon* (TFE), Polyethylene Foam (PEF) Insulation resistance: 10 GΩ or greater
Connector insulator material	Teflon* (TFE), Polybutylene Terephthalate (PBT) Insulation resistance: 10 GΩ or greater
Length	2 m (6.56 ft.) or less
Recommended cables (examples)	JIS standard 3C-2 V, 1.5D-2 V, MIL standard RG-58A/U

*Teflon is a registered trademark of DUPONT, Inc.

Communication Interfaces



RS-232C CABLE 9637
9pin-9pin, cross
Cord length: 1.8 m (5.91 ft.)



GP-IB CONNECTION CABLE 9151-02
Cord length: 2 m (6.56 ft.)

Related Products

Resistance Meter for the Ultra-Low Shunt Era

RM3543



- Inspection of 0.1 mΩ at a high accuracy of 0.16%, and a high resolution of 0.01 μΩ. Shunt resistor load inspection with superior accuracy and resolution.
- Excellent repetitive measurement accuracy
- Intuitive user interface and superb noise immunity ideal for use with automated equipment

Note: company names and product names appearing in this brochure are trademarks or registered trademarks of various companies.

HIOKI
HIOKI E. E. CORPORATION

ct