



NanoMixer-HV-Pro User Manual



| | |
|--|----|
| 1. Introduction | 3 |
| 1.1 Introduction | 3 |
| 1.1.1 Overview | 3 |
| 1.1.2 Read This Manual Before Use | 3 |
| 1.1.3 Intended Use | 3 |
| 1.2 About This Manual | 3 |
| 1.2.1 Purpose of This Manual | 3 |
| 1.2.2 Notes and Tips | 3 |
| 1.2.3 Printing Conventions | 3 |
| 2. Safety Instructions | 4 |
| 2.1 Safety Precautions | 4 |
| 2.1.1 Definitions | 4 |
| 2.1.2 General Precautions | 5 |
| 2.1.3 Flammable Liquids and Explosive Environments | 6 |
| 2.2 Emergency Procedures | 7 |
| 2.2.1 Overview | 7 |
| 2.2.2 Emergency Shutdown | 7 |
| 2.2.3 Restarting the Instrument | 7 |
| 3. System Description | 8 |
| 3.1 System Overview | 8 |
| 3.1.1 NanoMixer-HV-Pro System Overview | 8 |
| 3.1.2 System Diagram | 8 |
| 3.1.3 Instrument Diagram | 9 |
| 3.2 Microfluidic Chip | 10 |
| 3.2.1 Introduction | 10 |
| 3.2.2 Example: AB-X-T Microfluidic Chip | 12 |
| 3.3 User Interface | 13 |
| 3.3.1 Main Interface | 13 |
| 4. Installation | 16 |
| 4.1 Site Preparation | 16 |
| 4.1.1 Delivery, Storage, and Unpacking | 16 |
| 4.1.2 Installation Requirements | 17 |
| 4.2 Electrical Connection | 20 |
| 4.3 System Installation | 21 |
| 5. Operation | 22 |
| 5.1 Startup and Shutdown | 22 |
| 5.2 Operating Procedure | 23 |
| 5.2.1 Workflow | 23 |
| 5.2.2 Preheating | 23 |
| 5.2.3 Chip Replacement | 23 |
| 6. Troubleshooting | 25 |



Content

| | |
|--|----|
| 6.1 Mechanical Faults | 25 |
| 6.1.1 Backflow at Inlet | 25 |
| 6.1.2 Backflow at Outlet | 25 |
| 6.1.3 Microfluidic Chip Microchannel Blockage | 25 |
| 6.1.4 Insufficient Suction Due to Air in Tubing | 25 |
| 6.2 Electrical Faults | 25 |
| 6.2.1 Red Power Switch (PWR) Not Lit | 25 |
| 6.2.2 No Response After Clicking “Start” on the Main Interface | 25 |
| 7. Equipment Maintenance | 26 |
| 7.1.1 Repair and Preventive Maintenance | 26 |
| 7.1.2 Daily Cleaning | 26 |



1. Introduction

1.1 Introduction

1.1.1 Overview

This section contains important information regarding the product and this manual.

1.1.2 Read This Manual Before Use

All users must read this manual thoroughly before installing, operating, or maintaining the product.

Always keep this manual nearby while operating the product.

Do not install, operate, or maintain the product in any manner other than described in this user manual. Failure to follow instructions may expose you or others to potential personal injury hazards and may cause equipment damage.

1.1.3 Intended Use

This product is intended for use by trained laboratory personnel in academic and industrial research laboratories.

It is designed solely for research and further manufacturing purposes and must not be used for any clinical, surgical, or diagnostic applications.

1.2 About This Manual

1.2.1 Purpose of This Manual

This manual provides the information required for the safe installation, operation, and maintenance of the product.

1.2.2 Notes and Tips

Note: Notes contain important information essential for using the product correctly and maintaining its optimal condition.

Tip: Tips provide useful information that can help improve or optimize procedures.

1.2.3 Printing Conventions

Software items are indicated in **bold italics** throughout the manual.



2 Safety Instructions

About This Chapter

This chapter describes the safety precautions, labels, and symbols affixed to the product. In addition, it outlines emergency and recovery procedures.

Important

**Warning:**

All users must read and fully understand this General Safety section, as well as the specific safety precautions provided in each subsequent chapter. This ensures awareness of potential hazards associated with the product.

2.1 Safety Precautions

2.1.1 Definitions

This user document contains safety instructions for the safe use of the product, including “Warning” and “Caution” notices. Refer to the following definitions:

**Warning:**

A warning indicates a hazardous situation that, if not avoided, could result in death or serious injury.
Do not proceed until all specified conditions are met and clearly understood.

**Caution:**

A caution indicates a hazardous situation that, if not avoided, could result in minor or moderate injury.
Do not proceed until all specified conditions are met and clearly understood.



2.1.2 General Precautions

Always observe the following general precautions. In addition, there are context-specific precautions provided in the respective chapters where applicable.



Warning:

Do not operate the product in any manner not described in this user manual.



Warning:

Only personnel who have received proper training are authorized to operate and maintain the product.



Warning:

Only use accessories provided or recommended by Genizer.



Warning: Do not use the product if it is malfunctioning or has suffered any of the following types of damage:

- Damage to the power cord or plug
- Damage resulting from the product being dropped



Warning:

Always use appropriate personal protective equipment (PPE) when operating or maintaining the product.



Warning:

Keep the power switch easily accessible at all times. The power cord must also be easy to disconnect.



Warning: When handling hazardous chemicals or biological materials, always take appropriate protective measures, such as wearing protective clothing, goggles, and gloves resistant to the substances used. Follow all applicable local and national regulations regarding the safe operation and maintenance of this product.

2.1.3 Flammable Liquids and Explosive Environments



Warning

Explosion hazard: Risk assessment.

When using flammable liquids with this instrument, assess any hazards and implement necessary safety measures, including personal protective equipment, to reduce risks of electric shock, fire, and injury.

Consider the following:

- All personnel must understand local regulations for explosive environments.
- **Spill risk:** Establish safe procedures for handling hazardous liquids.
- **Fire risk:** Do not use liquids with autoignition below 250 °C; remove open flames or ignition sources nearby.
- **Static risk:** Static from operators can ignite flammable liquids; wipe with a damp cloth and avoid dry conditions.
- **Waste risk:** Collected or prepared liquids may be flammable; remove and dispose of containers promptly.



Warning:

Explosion Hazard: Do not turn on the main power switch if flammable liquids or vapors are present nearby.



Warning:

Explosion Hazard: When using flammable liquids, ensure the room ventilation meets local requirements to prevent the formation of an explosive atmosphere.



Warning:

Some chemicals used with the system may be flammable under certain conditions. Ensure these chemicals are used only under non-flammable conditions. Refer to local and/or national classifications for flammable liquids.

2.2 Emergency Procedures

2.2.1 Overview

This section explains how to shut down the NanoMixer-HV-Pro in emergency situations. It also describes the procedure for restarting the instrument.

2.2.2 Emergency Shutdown

In case of an emergency, follow these steps to stop operation:

| Step | Operation |
|------|---|
| 1 | Press the EMERGENCY STOP button on the user interface. Result: All operations stop immediately. |
| 2 | Turn the power switch to the O (off) position to completely shut down the instrument. |
| 3 | Unplug the power cord from the wall outlet. |

2.2.3 Restarting the Instrument

Before restarting the NanoMixer, ensure that the power switch on the back of the instrument is set to the **O (off)** position. Follow the steps below to restart the instrument:

| Step | Operation |
|------|---|
| 1 | Plug the power cord into a wall outlet. |
| 2 | Set the power switch to the I (on) position to restart the instrument. |

Result: After restarting, all system components will be restored. The instrument is ready for a new run/preparation.

3 System Description

3.1 System Overview

3.1.1 NanoMixer-HV-Pro System Overview

The NanoMixer-HV-Pro system consists of a main unit, microfluidic chip, and accessories, with all operations controlled via the main unit's integrated touchscreen interface.

The microfluidic chip features 316L stainless steel microchannels that can be sterilized under high pressure. They provide highly reproducible, uniform hydrodynamic focusing and millisecond-scale laminar mixing in continuous mode, ensuring stable LNP particle size and PDI output.

An optional high-precision online temperature sensor module allows real-time monitoring and recording of reaction temperature. It supports formulation optimization above the lipid phase transition temperature, effectively improves the solubility of poorly soluble active ingredients, and expands the process window.

3.1.2 System Diagram

The figure below shows the NanoMixer-HV-Pro instrument and the accessories included with the system.



System Description

| No. | Component Description |
|-----|-----------------------|
| 1 | Main unit |
| 2 | Power cord |
| 3 | Microfluidic chip |
| 4 | Accessories |
| 5 | Tool |

3.1.3 Instrument Diagram

The figure below shows the key components of the instrument and their locations.

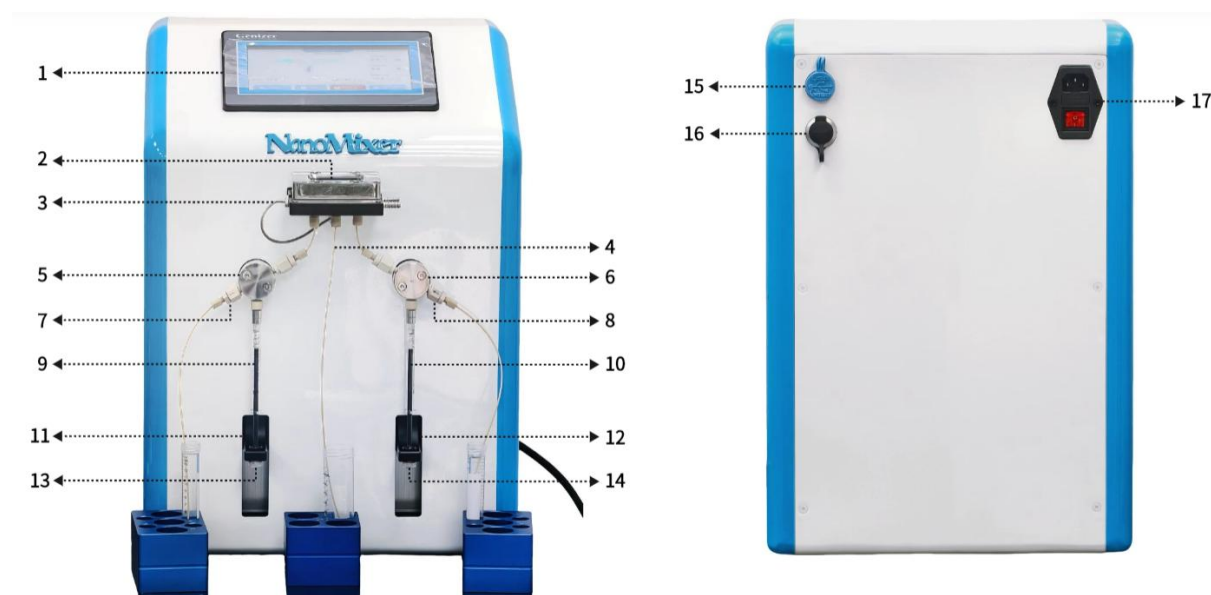

| No. | Component | Description |
|-----|---------------------------|--|
| 1 | User Interface | Touchscreen display for controlling the system. |
| 2 | Microfluidic Chip | 316L stainless steel chip assembly with precise internal geometry for fluid mixing and delivery. |
| 3 | RT Temperature Monitoring | Measures -50~200°C |
| 4 | RT Pressure Monitoring | Sanitary-grade; overpressure shutdown protection |
| 5 | Collection Port | Used for collecting samples and waste liquid |



System Description

| | | |
|----|-----------------------------|---|
| | | generated during preparation. |
| 6 | Automatic Switching Valve-L | Made of PTFE, PCTFE, and high-purity PEEK materials. |
| 7 | Automatic Switching Valve-R | Made of PTFE, PCTFE, and high-purity PEEK materials. |
| 8 | Injection Port - L | High-purity PEEK connector |
| 9 | Injection Port - R | High-purity PEEK connector |
| 10 | TLL Syringe-L | HAMILTON brand, $\pm 1\%$ accuracy, pressure-resistant up to 200 psi; optional sizes: 1.0 ml, 2.5 ml, 5 ml, 10 ml |
| 11 | TLL Syringe-R | |
| 12 | Syringe Pump-L | Servo-driven unit for high-precision flow control |
| 13 | Syringe Pump-R | |
| 14 | Anti-Slip Hand Screw-L | UNF 10-32 magnesium-aluminum alloy fixing screw |
| 15 | Anti-Slip Hand Screw-R | |
| 16 | USB Port | Data transfer |
| 17 | Ethernet Port | Device debugging. |
| 18 | Power | |

3.2 Microfluidic Chip

3.2.1 Introduction

The microfluidic chip uses integrated microfluidic mixing technology, which allows the mixing of multiple fluids. There are typically three geometric structures available for the NanoMixer-HV-Pro instrument (microfluidic chips can also be customized on demand). The table below describes the chip types and their applications (AB indicates the ability to mix 2 samples; Y indicates the chip channel geometry; T indicates temperature control functionality).

| Microfluidic Chip | Number of Phases | Channel Type | Temperature Control |
|-------------------|------------------|--------------|---------------------|
| AB-Y | 2 | Y | × |



System Description

| | | | |
|----------|---|---|---|
| AB-S | 2 | S | × |
| AB-X | 2 | X | × |
| AB-Y-T | 2 | Y | √ |
| AB-S-T | 2 | S | √ |
| AB-X-T | 2 | X | √ |
| ABC-Y | 3 | Y | × |
| ABC-S | 3 | S | × |
| ABC-X | 3 | X | × |
| ABC-Y-T | 3 | Y | √ |
| ABC-S-T | 3 | S | √ |
| ABC-X-T | 3 | X | √ |
| ABCD-Y | 4 | Y | × |
| ABCD-S | 4 | S | × |
| ABCD-X | 4 | X | × |
| ABCD-Y-T | 4 | Y | √ |
| ABCD-S-T | 4 | S | √ |
| ABCD-X-T | 4 | X | √ |



System Description

3.2.2 Example: AB-X-T Microfluidic Chip

Front View

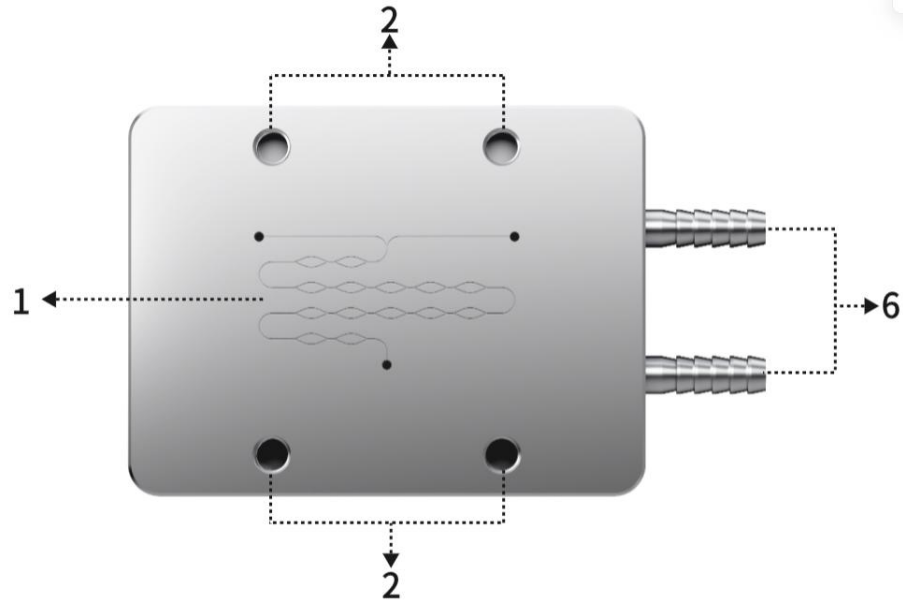

Back View

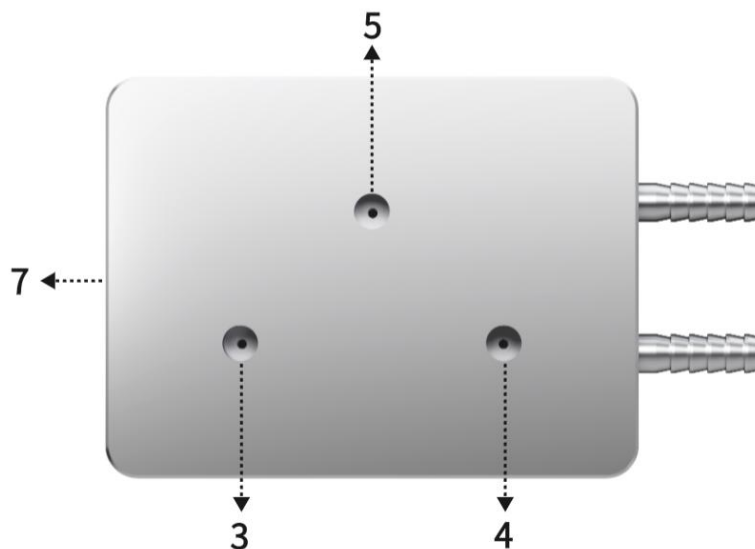

| No. | Component | Description |
|-----|------------------------|---|
| 1 | X-shaped Microchannel | Geometry of the mixer |
| 2 | Upper Cover Screw Hole | UNF 1/4-20 screws secure the upper and lower covers |



System Description

| | | |
|---|------------------------------|---|
| 3 | Left Pump Inlet | UNF 1/4-28 threaded hole with PEEK split conical connector |
| 4 | Right Pump Inlet | |
| 5 | Outlet | UNF 1/4-28 threaded hole with PEEK split conical connector |
| 6 | Pagoda Connector | Outer diameter $\phi 6$ mm, used to connect silicone tubing |
| 7 | Temperature Sensor Interface | For connecting an M6-threaded PT100 temperature sensor |

3.3 User Interface





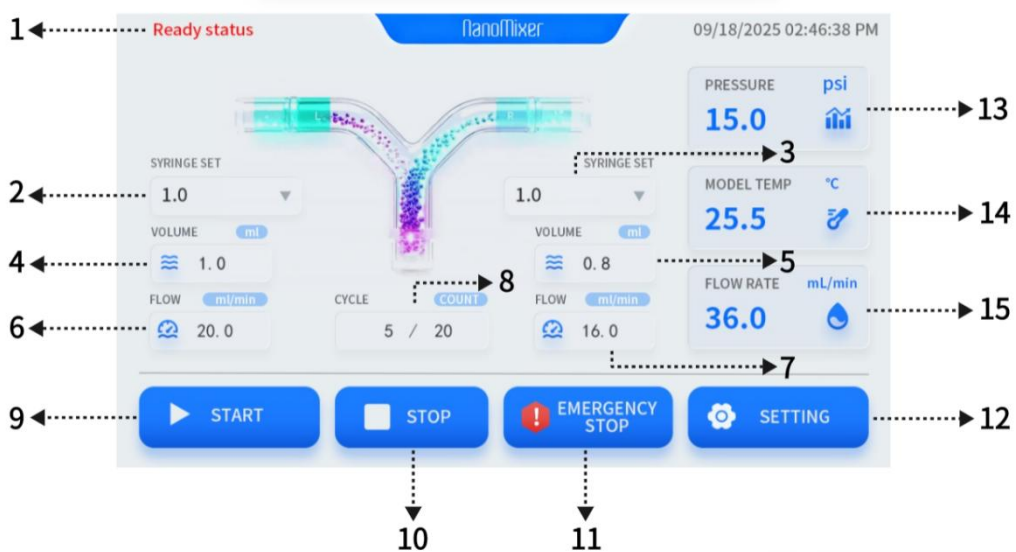

3.3.1 Main Interface

The figure below shows the operating interface of the instrument.

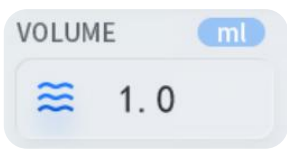
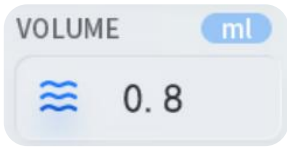
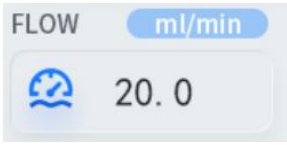
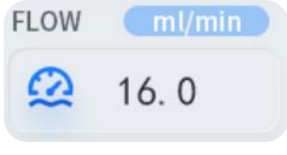
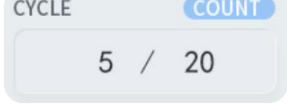

| No. | Name | Description |
|-----|---------------------|---|
| 1 | Ready status | Displays the current operating status of the device |
| 2 | SYRINGE SET 1.0 | Select left pump syringe: 1.0, 2.5, 5, or 10 ml |
| 3 | SYRINGE SET 1.0 | Select right pump syringe: 1.0, 2.5, 5, or 10 ml. |

System Description

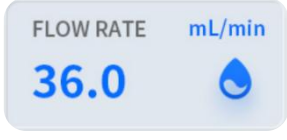
| | | |
|----|---|--|
| 4 |  | Set single-stroke volume for left pump (ml) |
| 5 |  | Set single-stroke volume for right pump (ml) |
| 6 |  | Set left pump speed (0–20 ml/min) |
| 7 |  | Set right pump speed (0–20 ml/min) |
| 8 |  | Set number of cycles; left number shows completed cycles |
| 9 |  | Start operation |
| 10 |  | Stop operation (stops after completing current stroke) |
| 11 |  | Emergency stop (immediate halt) |
| 12 |  | Enter customer setup interface |
| 13 |  | Display inlet pressure (units can be switched among psi, MPa, Bar) |
| 14 |  | Display chip temperature (°C) |
| 15 |  | Display outlet volumetric flow (ml/min) |



System Description

3.3.2 CUSTOMER SETUP

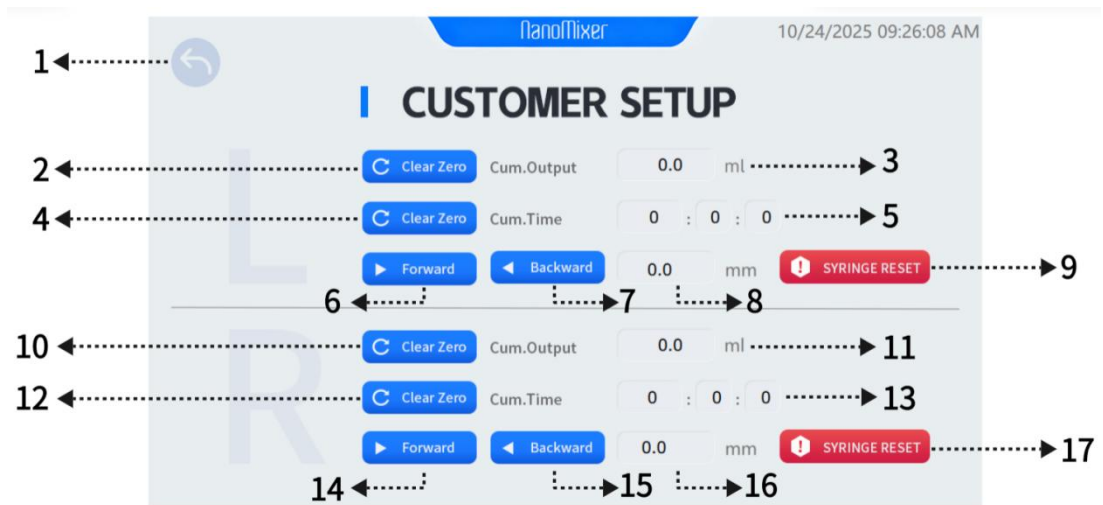

| No. | Name | Description |
|-----|------|--|
| 1 | | Return to main interface |
| 2 | | Reset cumulative processed volume (left pump) |
| 3 | | Display cumulative processed volume (left pump, ml) |
| 4 | | Reset total operation time (left pump) |
| 5 | | Display cumulative machine runtime (left pump) |
| 6 | | Hold to move left syringe upward; release to stop |
| 7 | | Hold to move left syringe downward; release to stop |
| 8 | | Display left syringe travel distance |
| 9 | | Return left syringe to lowest point for replacement |
| 10 | | Reset cumulative processed volume (right pump) |
| 11 | | Display cumulative processed volume (right pump, ml) |
| 12 | | Reset total operation time (right pump) |
| 13 | | Display cumulative machine runtime (right pump) |



| | | |
|----|---|--|
| 14 |  | Hold to move right syringe upward; release to stop |
| 15 |  | Hold to move right syringe downward; release to stop |
| 16 |  | Display cumulative processed volume (right pump, ml) |
| 17 |  | Return right syringe to lowest point for replacement |

4 Installation

This section describes the site planning and preparation required before installing the instrument.

4.1 Site Preparation

4.1.1 Delivery, Storage, and Unpacking

Introduction

This section provides guidance on inspection upon receipt of the shipment, storage conditions before installation, and safety considerations for unpacking and handling the instrument. It is recommended that two people handle the unpacking and moving process, which can be safely performed without special tools.

Receiving the Shipment

- Inspect the carton for visible damage. If any damage is found, note it immediately on the delivery receipt and notify your sales representative.
- Move the carton to a safe indoor location for storage.

Storage Requirements

Cartons should be stored in a protected indoor environment. For unopened cartons, the storage location must meet the following conditions:

| Parameter | Allowed Range |
|-----------------------------|----------------------------|
| Storage ambient temperature | 15 °C to 35 °C |
| Relative humidity | 25% to 65%, non-condensing |

Unpacking the Instrument

Retain all original packaging materials. If the system must be repackaged for transport or other purposes, using the original packaging is critical to ensure safe packaging of the system.

4.1.2 Installation Requirements

Introduction

This section describes the requirements for the room where the system will be installed.

Dimensions and Weight

The following table shows the dimensions of the NanoMixer-HV-Pro:



| Parameter | Value |
|-----------|-----------------|
| W | 36 cm (14.2 in) |
| D | 40 cm (15.7 in) |
| H | 48 cm (18.9 in) |
| Weight | 16 kg (35.3 lb) |

**Warning**

Power Cord Access: Do not obstruct access to the power cord. It must always remain easily accessible for disconnection.

**Caution:**

Ensure that the system is placed on a stable, level workbench with adequate ventilation space.

**Caution:**

This instrument is for indoor use only.

Space Requirements

The NanoMixer-HV-Pro can be installed on a standard laboratory workbench. Prepare a clean workspace on a stable lab bench that meets the specifications in the table below. Ensure there is sufficient space to rotate the product on the workbench to allow maintenance personnel access to the rear panel.

| Parameter | Specification |
|------------------------------------|---|
| Minimum Operating Area (W × D × H) | 40 x 48 x 73 cm 15.7 x 18.9 x 28.7 in |
| Load Capacity | Must safely support the weight of the product and all accessories |
| Workbench Levelness | Level deviation within $\pm 2^\circ$ |

Environmental Requirements

The installation environment must meet the following specifications:

| Parameter | Requirement |
|----------------------|----------------------------|
| Location | Indoor only |
| Ambient Temperature | 15 °C to 35 °C |
| Relative Humidity | 25% to 65%, non-condensing |
| Atmospheric Pressure | 0.070 to 0.106 MPa |
| Maximum Altitude | 2000 m |



| | |
|------------------|---|
| Pollution Degree | 2 |
|------------------|---|

General Requirements:

- The room should have effective exhaust ventilation.
- Maintain a clean environment to minimize airborne dust

Power Requirements

The product's power input requirements are as follows:

| Parameter | Requirement |
|-----------------------|--|
| Rated Voltage | 100 - 240 V AC |
| Voltage Frequency | 50/60 Hz |
| Maximum Current | 4 A |
| Outlet Type | Must use a properly grounded power outlet |
| Over voltage Category | II |
| Outlet Distance | Within 1 m of the device (based on standard power cord length). If extended, use a compliant extension cord. |

Note: To ensure reliable operation, the main power supply must be stable and within the specifications above, avoiding transient or sustained voltage fluctuations beyond the limits.

Device Output

| Parameter | Requirement |
|----------------|-------------|
| Output Voltage | 24 V DC |
| Output Current | 4.1 A |
| Output Power | 100 W |

Power Quality

The main power supply must always be stable and meet the specifications to ensure reliable operation. Avoid transient or slow variations beyond the specified limits.



4.2 Electrical Connection

Introduction

This section describes how to connect the product to the power supply. If the product is relocated, ensure it is reconnected to a compliant power source.

Safety Precautions

**Warning**

Power Cord: Use only the power cord supplied with the NanoMixer-HV-Pro or approved for use with this instrument.

**Warning**

Power Voltage: Before connecting the power cord, ensure that the wall outlet voltage matches the instrument's requirements.

Connecting the Power to the Product

Follow the steps below to connect the product to the power supply:





**Warning**

Protective Grounding: To reduce the risk of electric shock, the product must always be connected to a properly grounded power outlet.

| Step | Operation |
|------|--|
| 1 | Insert the power cord into the socket on the back of the instrument.  |
| 2 | Plug the other end of the power cord into a properly grounded wall outlet. Ensure that the outlet voltage meets the specifications listed in Section 4.1.2 “ Electrical Requirements ”. |
| 3 | Press the red power button on the instrument to start the system. |

4.3 System Installation

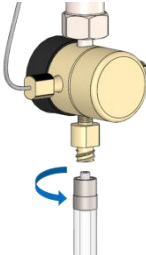
Follow the steps below to install the system:

| Step | Operation |
|------|--|
| 1 | Wait for the system to start and enter the main interface. |
| 2 | Click  to enter the “ CUSTOMER SETUP ” screen. |
| 3 | Click  for the left pump. The black plunger of the left pump will move to the lowest position. |
| 4 | Take out the syringe.  |
| 5 | Turn the syringe clockwise to engage it with the machine interface. Caution: Do not overtighten. Otherwise, the connector may be damaged.  |
| 6 | a. Pull down the black plunger rod of the syringe until it is fully seated on the black syringe holder. b. Use the silver knurled 10-32 screw and rotate clockwise to secure the syringe in place.  |
| 7 | Return to the main interface, click “ SYRINGE SET ” to select the syringe model. |
| 8 | Repeat steps 3–7 to install the syringe for the right pump. |

5 Operation

5.1 Startup and Shutdown

Starting the Instrument

To start the instrument, switch the power button on the back of the instrument from “0 (OFF)” to “I (ON)”.



When the instrument starts:

- The screen lights up and the status indicator turns on.
- The main interface appears when the system is ready.

Shutting Down the Instrument



To shut down the instrument, switch the power button on the back from “I (ON)” to “0 (OFF)”.



5.2 Operating Procedure

5.2.1 Workflow

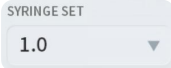
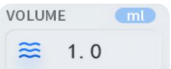
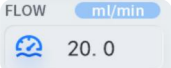
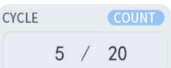
The table below outlines the main stages of operation:

| Step | Operation |
|------|--|
| 0 | <i>Optional: Preheating</i> |
| 1 |  Select the (Left/Right) syringe model. |
| 2 |  Set the single-stroke volume for (Left/Right). |
| 3 |  Set the speed for (Left/Right). |
| 4 |  Input the number of cycles; the instrument stops automatically after the specified cycles. |
| 5 | Press  to run the instrument. |
| 6 | In case of emergency, press  to immediately halt the instrument. |

5.2.2 Preheating

Connect one end of the silicone tubing to the barbed fitting and the other end to the chiller.

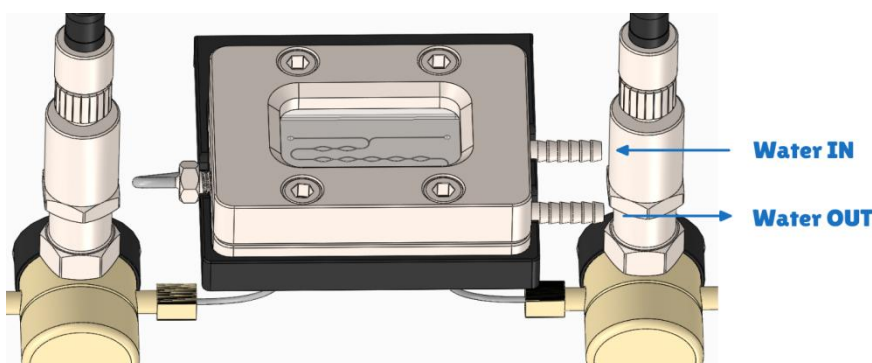

5.2.3 Chip Replacement

Replace the microfluidic chip with the desired channel type as needed.

| Step | Operation |
|------|-----------|
|------|-----------|

- | | |
|---|---|
| 1 | Loosen the PEEK split conical connector counterclockwise and separate it from the chip body. |
|---|---|

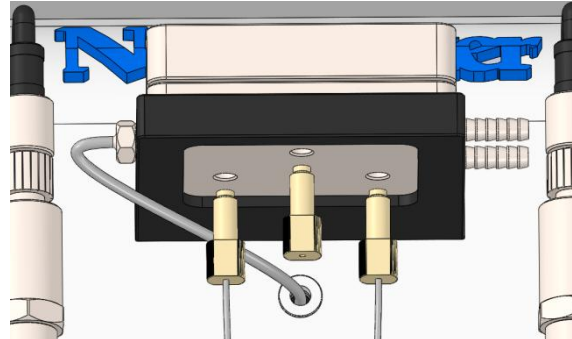

- | | |
|---|---|
| 2 | Loosen the temperature sensor counterclockwise and detach it from the chip body. |
|---|---|

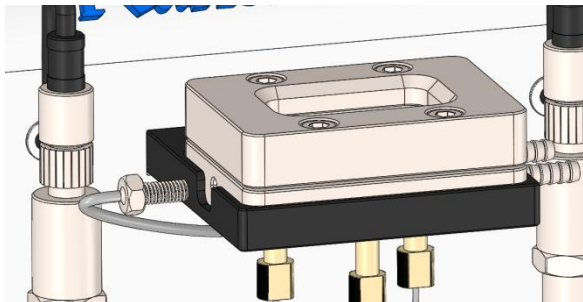

- | | |
|---|--|
| 3 | Remove the chip module from the bracket (if connected to a water bath temperature control system, disconnect the silicone tubing from the barb fitting first). |
|---|--|

- | | |
|---|--|
| 4 | Use a hex key to unscrew the four fastening screws, remove the top cover and tempered glass plate, and place them gently on a clean surface. |
|---|--|

- | | |
|---|---|
| 5 | Take out the new microfluidic chip and gently wipe the channel surface with a lint-free paper moistened with ethanol to ensure it is clean and free of residue. |
|---|---|

- | | |
|---|--|
| 6 | Take out the Nanomixer seal membrane from the accessories, peel off the protective film, align it centrally on the chip, and press out any trapped air. |
|---|--|

- | | |
|---|--|
| 7 | Replace the tempered glass plate and top cover in order, and tighten the four fastening screws. |
|---|--|

- | | |
|---|---|
| 8 | Reattach and tighten the temperature sensor and PEEK split conical connector in their original positions. |
|---|---|

- | | |
|---|---|
| 9 | Pre-flush the chip with pure water and check for leaks. |
|---|---|

- | | |
|----|---|
| 10 | After confirming there are no issues, the chip is ready for normal use. |
|----|---|

6 Troubleshooting

6.1 Mechanical Faults

6.1.1 No Liquid Intake at Inlet

Symptom: The syringe does not draw liquid during the suction stroke.

Cause: The PEEK split conical connector at the inlet is loose.

Solution: Tighten the loose fitting.

6.1.2 Backflow at Outlet

Symptom: Liquid flows back at the outlet while the syringe is in the suction stroke.

Cause: The automatic switching valve has failed.

Solution: Replace the switching valve assembly.

6.1.3 Microfluidic Chip Microchannel Blockage

Symptom: Sudden rise in internal system pressure causes connected capillaries to detach due to high pressure.

Cause: The microchannels on the chip surface are blocked.

Solution: Clean the chip microchannels.

6.1.4 Insufficient Suction Due to Air in Tubing

Symptom: The syringe does not fully fill, and air is present in the liquid.

Cause: Air is trapped inside the tubing system.

Solution: Perform air purging. Pre-flush the system with buffer solution at a flow rate of 1 mL/min. Repeat the flushing process until all air is expelled.

6.2 Electrical Faults

6.2.1 Red Power Switch (PWR) Not Lit

- Check if the fuse is blown; replace if necessary.
- Check the device power connection; reconnect if faulty.
- Check the wall socket; ensure the plug is fully inserted.

6.2.2 No Response After Clicking “Start” on the Main Interface

- Turn off the power and wait  30 seconds before restarting.
- The system will rebuild, which takes a few seconds. If the problem persists after restarting, contact Genizer after-sales service for assistance.

7 Equipment Maintenance

7.1.1 Repair and Preventive Maintenance

- The required frequency of repair and preventive maintenance depends on usage and the specific applications performed.
- It is generally recommended to schedule maintenance and preventive servicing at least once per year. Adhere to the recommended maintenance intervals.
- If any component fails, it is recommended to replace it immediately to prevent further damage to the system. Following these guidelines will help maximize the system's service life.

7.1.2 Daily Cleaning

- The syringe holder and chip bracket are the most common areas for spills, droplets, and material buildup. Surfaces can be wiped with ethanol or isopropanol.
- If fluid flows along the syringe holder into the interior of the instrument, there is no need to stop the machine during operation because the system is designed with a dry-wet separation; small amounts of liquid will not affect safety. After stopping the instrument, wipe the area with a clean, lint-free cloth.
- If fluid splashes onto the plastic housing, wipe it promptly to keep the exterior dry and avoid damage to the paint.
- To clean the instrument body, cover, and all internal components, wipe surfaces with any of the following:
 - a. Warm water with a mild, non-abrasive detergent
 - b. Ethanol
 - c. Isopropanol
- Use a soft cloth to wipe the surfaces, avoiding scratches that could affect the appearance of the instrument.

