



**keonn** Retail RFID  
Systems

## AdvanLift™

Lift and learn  
interactive system



Tel: +34 931 814 477

Barcelona  
London



ES France - Département Composants & Modules  
127 rue de Buzenval BP 26 - 92380 Garches



Tél. 01 47 95 99 89



e-mail : [comp@es-france.com](mailto:comp@es-france.com)  
Site Web : [www.es-france.com](http://www.es-france.com)



### Benefits:

- Increases sales at retail stores
- Increases conversion rate
- Increases cross-selling
- Improves the customer shopping experience
- Provides recommendations
- Fun to use
- Advertising space
- Generates information about user interests
- The content and user interface can be updated remotely

### Applications:

- Cosmetic stores
- Drugstores
- Shoes stores
- Gourmet stores

### Product overview

AdvanLift is a **product recommendation** and **cross-selling** system with tray ideal for cosmetics, footwear, wine, etc.

AdvanLift uses RFID technology and, optionally, an interactive screen to improve the shopping experience of customers at retail stores.

By simply picking up a product from the tray of AdvanLift, customers see benefits, experts' advice, videos of how to use the product, and recommended products.

The **use process** is as follows:

1. The customer picks up an item from the shelf
2. The RFID subsystem of AdvanLift detects which product has been picked up
3. The screen of AdvanLift shows images of the product, together with benefits, experts' advice, videos of how to use the product, and recommended products.
4. With AdvanLift touch screen, the customer can browse through other products, request that an employee brings one product, etc.

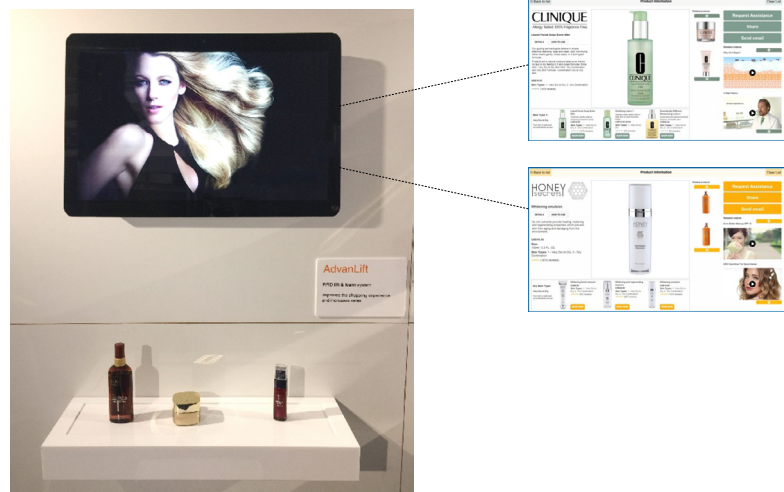

The content and user interface of AdvanLift can be updated remotely very easily, by means of the **AdvanCloud cloud-based software**.

All the events are registered and stored in AdvanCloud. This information can then be analysed for **business intelligence** purposes:

- Number of users that use AdvanLift
- Products that customers picked up from the tray of AdvanLift
- Recommended products that customers select on the screen
- Products that the customers request to be brought by an employee
- Etc.

AdvanLift **comprises**:

- RFID subsystem, with four antennas
- Optional: touch screen
- Embedded computer
- Content and user interface management cloud-based software



### Finishing options for the frame

Options	The color of the tray can be customized
Default finish	White

### Technical specifications

Screen size	16 inches, 21 inches, 32 inches
Touch screen technology	Projected capacitive
RFID frequency	Dual Band (ETSI and FCC)
RF Power output	Programmable from -5 dBm to 30 dBm in 0.5 dBm steps
Standard Compliance	EPC global Gen2 (ISO 18000-6C)
RFID Antennas polarization	Circular
Size	641 mm x 216 mm x 74 mm 25.2 inches x 8.5 inches x 2.9 inches
Weight of the tray	14,5 Kg
Temperature range	0°C to +40°C

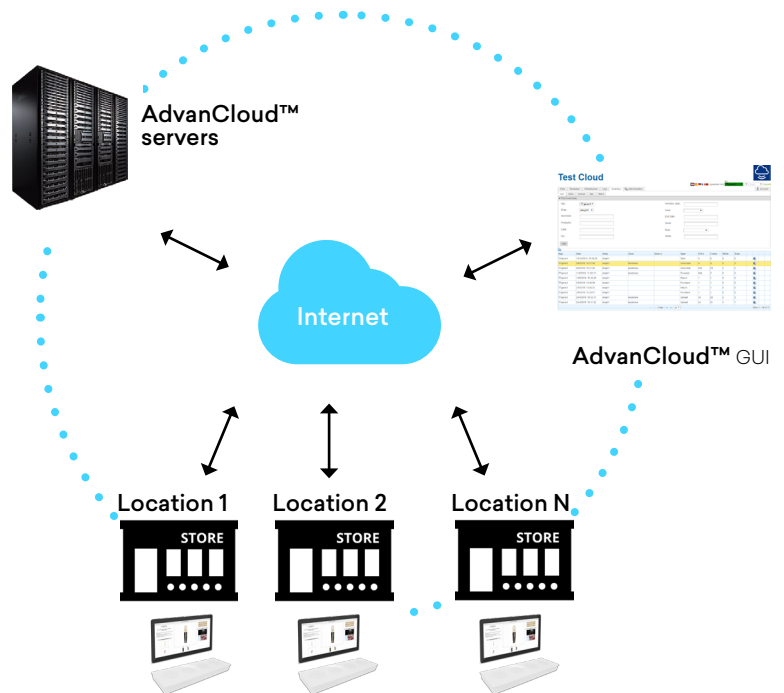



## Mechanical specifications of the AdvanLift shelf

### Screen 16 inches

units in mm

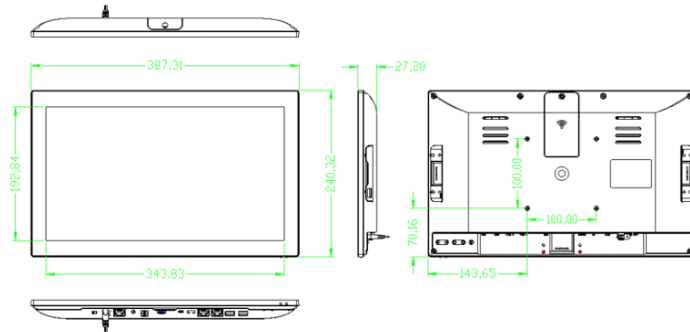

### Screen 21 inches

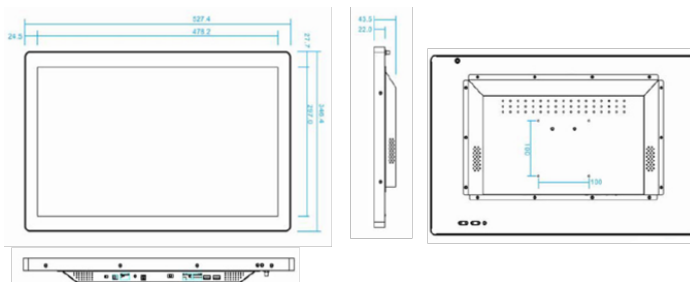

### Screen 32 inches

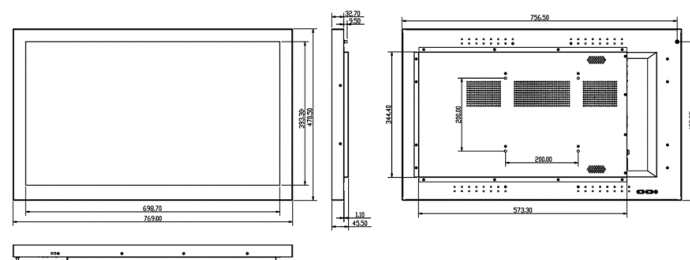

### Product codes for ordering

ADLF	-	O	-	FF	-	mmm	
							<b>O = Options</b>
		16t					16 inches touch screen
		21t					21 inches touch screen
		32t					32 inches touch screen
		-					simple set, no screen
							<b>FF = Frequency Band</b>
				EU			865,6 MHz - 867,6 MHz
				US			902,0 MHz - 928,0 Mhz
							<b>mmm = Model</b>
						400	Model number

Examples:

#### ADLF-US-400:

- RFID shelf only (without screen nor computer)
- Frequency band : 902,0 MHz - 928,0 Mhz
- Model 400

#### ADLF-21t-EU-400:

- 21" touch screen
- Frequency band : 865,6 MHz - 867,6 MHz
- Model 400





Copyright © Keonn Technologies S.L.  
All rights reserved.

Information in this publication  
supersedes all earlier versions.  
Specifications subject to change  
without notice.



ES France - Département Composants & Modules  
127 rue de Buzenval BP 26 - 92380 Garches



Tél. 01 47 95 99 89



e-mail : [comp@es-france.com](mailto:comp@es-france.com)  
Site Web : [www.es-france.com](http://www.es-france.com)