

APD-7101 (AMB-232A)

10.4" TFT Industrial Display Monitor

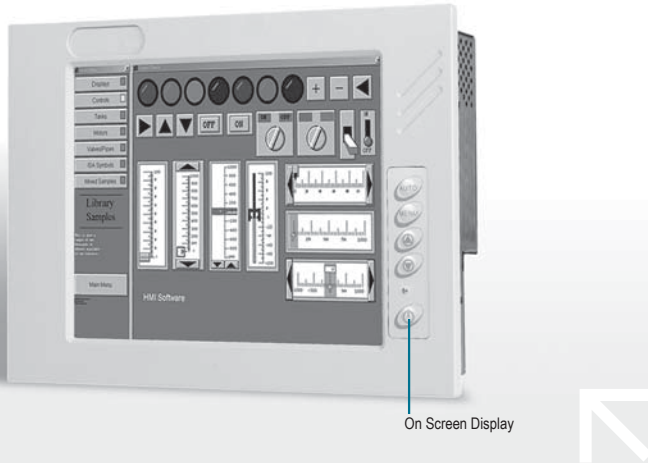

On Screen Display

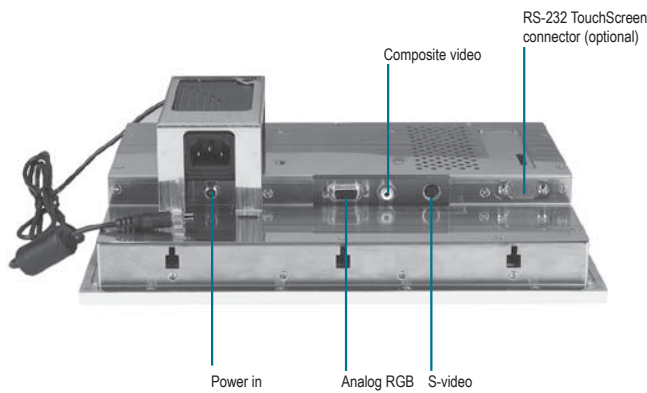

Power in

Analog RGB

S-video

Composite video

RS-232 TouchScreen connector (optional)

Rigorous IP65 Test

Completely protected against dust



Protected against jets of water from all directions

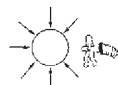

Features

- 10.4" TFT SVGA LCD
- Stainless Steel Closed-frame Architecture with Aluminum Front Panel
- RGB, Composite Video, S-video Input Signal Selectable
- Picture-In-Picture Function Enable
- VESA 75mm Standard Screw Holes



Specifications

System	
Input Signal	RGB, Composite video, S-video
On Screen Display Control	Brightness, contrast, phase, sharpness, AutoTune, PIP, H/V-position
OS support	MS DOS, Windows® 2000, Windows® XP (TouchScreen model does not support Windows® XP)
Mechanical	
Construction	Stainless steel chassis & aluminum alloy front panel
Front Panel Color	RAL-7305
Mounting	Panelmount Optional: Wallmount kit, Swivel ARM, Desk stand
Dimension	12.2" (W) x 8.5" (H) x 2.2" (D) (309mm x 216mm x 54.8mm)
Carton Dimension	14.7" (W) x 14.1" (H) x 13" (D) (373mm x 359mm x 330mm)
Gross Weight	12.4 lb (5.6Kg)
Environmental	
Operating Temperature	32°F~113°F (0°C to 45°C)
Storage Temperature	-4°F~140°F (-20°C to 60°C)
Operating Humidity	10% to 90%@40°C, non-condensing
Vibration	1G / 5 ~ 500Hz (Random) / Operation
Shock	15G peak acceleration (11 msec. duration) / operation
EMC	CE/FCC Class A
Power Supply	
External Power Adaptor 60W	Input: 100 to 240 ±10%V AC, Full Range Output: +12V DC@5A
LCD	
Display Type	10.4" color TFT LCD
Max. Resolution	800 x 600
Max. Colors	262K
Dot Size	0.264mm x 0.264mm
Luminance	230 cd/m ² (TYP.)
Viewing Angle	120° (H) / 100° (V)
Brightness Control	Yes
Back Light MTBF	20,000hrs

Dimension

Unit: mm

Cutout Size: 291.2 x 198.2mm

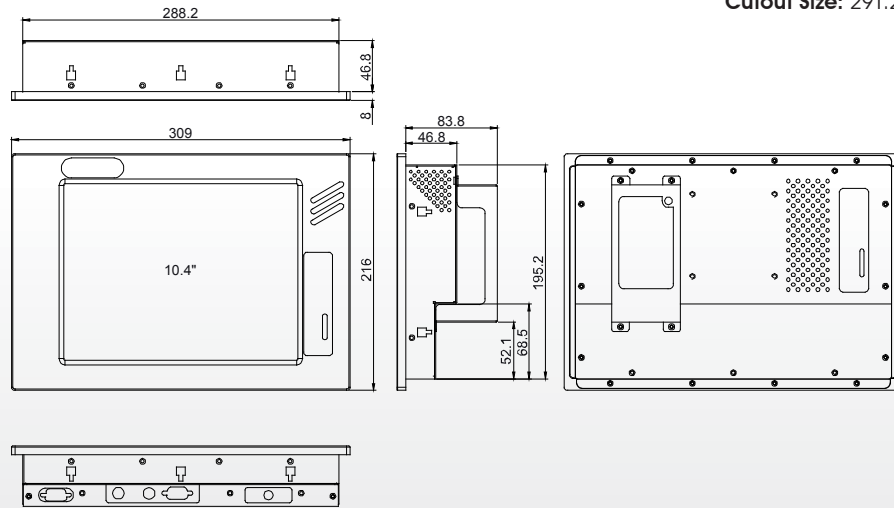

TouchScreen (Optional)	
Type	8-wire, Analog Resistive
Resolution	1024 x 1024
Light Transmission	76% ± 2
Lifetime	1 million activations
OS Support	MS DOS, Windows® 2000

Ordering Information

- **AMB-232A-F1**
10.4" SVGA TFT Display Monitor
- **AMB-232AT-F1**
AMB-232A-F1 w/Resistive TouchScreen

Optional Accessories

- **ARM-LA0115**
Swivel Arm with VESA 75/100mm Standards
- **ARM-WK075-0**
Wallmount Kit with VESA 75/100mm Standards
- **STAND-8150B0**
Desktop Stand with VESA 100mm Standards
- **STAND-8150S0**
Desktop Stand with VESA 100mm Standards (Silver)

01

Medical Station Solutions - ONYX Series

02

Medical Display Solutions - ONYX Series

03

Operator Panel Solutions - OMNI Series

04

Robust Panel PC Solutions

05

Embedded Controller - Boxer S Series

06

Embedded Controller - BOXER Series

07

Industrial Monitor Solutions

08

Sun-readable & Vehicle LCD Monitors

09

Industrial Workstation Solutions

10

Common Accessories