

## Features

- Onboard Intel® Atom™ N270 1.6 GHz
- IP-67 Water-Proof & IEC60945 Ed.4 Certificated
- 12.1" 500 Nits XGA LED Backlight (FOX-121HTT)
- 12.1" 1000 Nits XGA LED Backlight (FOX-121STT)
- Fanless Operation
- Backlight On/Off & Brightness Adjustment, Min. 10 Nits
- WiFi, GPRS, GPS (Optional)

Note: IEC60945 ed.4 Compliant with the conditions: 8.2.1/ 8.2.2/ 8.3/ 8.4.2.6/ 8.7/ 8.8



## Specifications

System	
Processor	Intel® Atom™ N270 1.6 GHz
System Memory	DDR2 SODIMM, Up to 2GB
LCD/CRT Controller	Intel® 945GSE
Ethernet	10/100/1000Base-TX, RJ-45 x 1
I/O Port	USB2.0 x 2, RS-232 x 1, RS-232/422/485 x 1, LAN x 1
Storage Disk Drive	2.5" SATA Hard Disk Drive / CompactFlash™ Slot (Internal)
Expansion Slot	Mini-PCI x 1
OS support	Windows® CE 6.0, Windows® XP Embedded, Windows® XP, Windows® 7, Windows® Embedded Standard 7, Linux Fedora
Mechanical	
Construction	Sealed Aluminum Alloy Chassis
Color	Silver Gray
Mounting	VESA 75/100
Dimension	13.58"(W)x 11.1"(H) x 2.35"(D) (345mm x 282mm x 60mm)
Carton Dimension	20.23"(W)x 9.72"(H) x 20.31"(D) (514mm x 247mm x 516mm)
Gross Weight	21.46 lb (8 Kg)
Net Weight	17.41 lb (6.5 Kg)
Environmental	
Operating Temperature	-4°F~131°F (-20°C~55°C)
Storage Temperature	-4°F~158°F (-20°C~70°C)
Storage Humidity	5%~90% @ 40°C, non-condensing
Vibration	3 g rms/ 5~ 500Hz/ operation – With HDD
Shock	20 G peak acceleration (11 msec. duration)
Safety	IP-67 (SGS report), IEC60945
EMC	CE /FCC class A
Power Supply	
DC Input	DC 9~30V
LCD	
Display Type	12.1" TFT-LCD
Max Resolution	1024 x 768
Max. Colors	262K colors
Luminance	500 cd/m <sup>2</sup> / 1000 cd/m <sup>2</sup>
Viewing Angle	160°(H), 160°(V) / 160°(H), 120°(V)
Back Light	LED
Back Light MTBF (hours)	50,000 / 60,000
Touchscreen	
Type	5-wire, Analog Resistive
Resolution	2048x2048
Light Transmission	>80%
Life time	35 Million activations

# FOX-121

## Dimension

Unit: mm

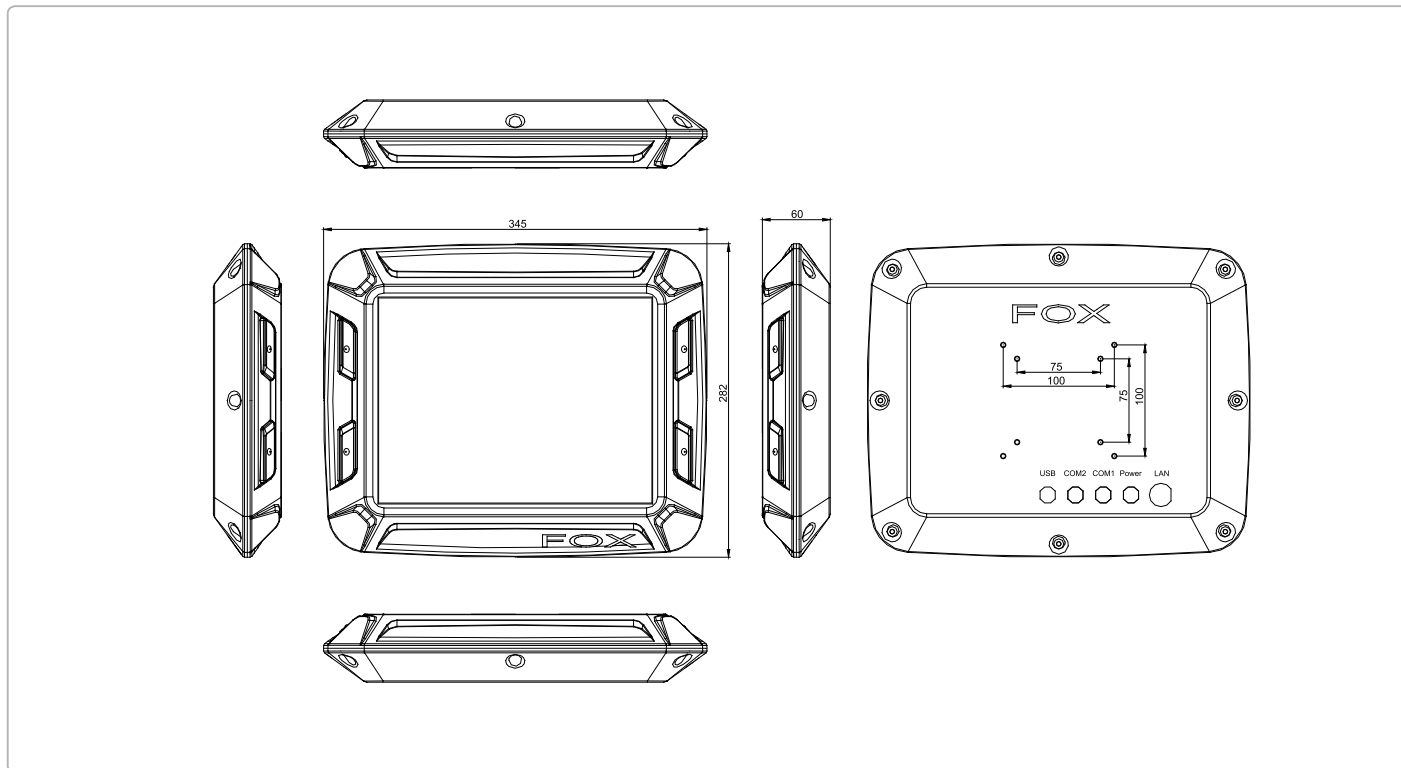

## Ordering Information

- **TF-FOX-121HTT-A1-1010**  
MPWP Panel PC, Intel® Atom™ N270 1.6GHz, 12.1" 500 nits with Bonding, DC 24V, R-TS, 1 GB RAM, LAN
- **TF-FOX-121HTT-A2-1010**  
MPWP Panel PC, Intel® Atom™ N270 1.6GHz, 12.1" 500 nits with Bonding, DC 24V, R-TS, 1 GB RAM, LAN, 1 antenna
- **TF-FOX-121HTT-A3-1010**  
MPWP Panel PC, Intel® Atom™ N270 1.6GHz, 12.1" 500 nits with Bonding, DC 24V, R-TS, 1 GB RAM, LAN, 2 Antennas
- **TF-FOX-121STT-A1-1010**  
MPWP Panel PC, Intel® Atom™ N270 1.6GHz, 12.1" 1000 nits with Bonding, DC 24V, R-TS, 1 GB RAM, LAN
- **TF-FOX-121STT-A2-1010**  
MPWP Panel PC, Intel® Atom™ N270 1.6GHz, 12.1" 1000 nits with Bonding, DC 24V, R-TS, 1 GB RAM, LAN, 1 antenna
- **TF-FOX-121STT-A3-1010**  
MPWP Panel PC, Intel® Atom™ N270 1.6GHz, 12.1" 1000 nits with Bonding, DC 24V, R-TS, 1 GB RAM, LAN, 2 Antennas

## Accessories in Packing

- **1700090208**  
COM (D-SUB) Cable with Waterproof M12 Connector (FOX series)
- **1709080251**  
Two USB Y Cables with Waterproof M12 Connector (FOX series)
- **M990FOX001**  
3-pin Water-proof Cap Connector for DC-in or Audio Line-out Port (FOX series)
- **P990FOX001**  
Water-proof Cap Connector for LAN Port of FOX series (RJ-45-compliance)

## Optional Accessories

- **STAND-FOXSO**  
Desktop Stand
- **1757910004**  
AC Adapter 100W
- **1702031803**  
Power Cord 3P-250V
- **9761F12100**  
GPRS/GPS Kit
- **9761F12101**  
WiFi Kit, 802.11 b/g
- **Industrial Grade 2.5" SATA SSD**
- **Industrial Grade CompactFlash™ Card**