

Heavy-Duty Industrial Panel PC

IPPC15B7-RE/IPPC15B9-RE/
IPPC17B9-RE/IPPC19B9-RE



■ Highlight

- Fanless design modularized Panel PC
- IP65 front panel protection
- 5-wire resistive touch panel
- Slim & compact design

■ Features



Modular design,
swappable
Computing box
(For 15" model only)



Intel® Core I platform,
fanless (B9 series)

■ I/O View



IPPC B9 Series I/O



IPPC B7 Series I/O



Riser card expansion
B9 series 2 X PCI
B7 series 1 X PCI



Optional wide-range
DC power B7 series
only

Heavy-Duty Industrial Panel PC

Specification

Model No.	IPPC15B7-RE	IPPC15B9-RE	IPPC17B9-RE	IPPC19B9-RE
System				
Processor	Intel® Atom™ Processor D2550 1M Cache, 1.86GHz		Intel® Core i3-2340UE 1.3GHz	
System Memory	1x DDR3-1066 SO-DIMM Up to 4GB		2x DDR3 1333 SO-DIMM Up to 16GB	
External I/O				
USB	4x USB 2.0		2x USB 2.0 2x USB 3.0	
Serial/Parallel	1x D-SUB9 RS-232/422/485 COM1		3x D-SUB9 COM1/COM2/COM3	
Audio	MIC in/ Line out phone jack			
Graphics	1x VGA		1x DVI-I	
LAN	2x GbE LAN RJ-45			
Digital I/O	1x Digital I/O			
Keyboard/Mouse	None			
Membrane Control	None			
Power	1x 3pin DC power connector 1x Power on/off rock switch			
Storage Space				
HDD	1x 2.5" SATA2			
Movable Slot	None		1x CFAST slot	
Expansion				
Onboard Expansion Bus	1x Mini-PCIe half/full size		2x Mini-PCIe half/full size	
Expansion Slot	1 x PCI slot		2 x PCI slot	
Display				
Display Type	15" TFT-LCD		17" TFT-LCD	19" TFT-LCD
Max. Resolution	1024 x768		1280 x 1024	
Max. Color	16.2M		16.7M	
Luminance (cd/m2)	400		350	
View Angle (H°/V°)	160/140		170/170	170/160
Contrast	700:1		800:1	1000:1
Backlight Lifetime(hrs)	50000			
Touch Screen				
Type	Resistive			
Interface	USB			
Light Transmission (%)	80		81	
Power				
Power Input	9V~32V DC input 12V DC input(option)		12V~24VDC input	
Mechanical				
Construction	Aluminum front bezel and black steel back cover with aluminum heat-sink			
IP Rating	IP65 front bezel			
Mounting	Panel and VESA 75x75mm / 100x100mm			
Dimensions (mm)	388 x 315 x 63.6	388 x 315 x 110.14	430 x 365 x 118.1	465 x 390 x 118.1
Net Weight (kgs)	6.5kgs	7.9kgs	TBD	TBD
Environment				
Operating Temperature(°C)	0°C~ 50°C(with SSD)/ 0°C~ 40°C(with HDD)			
Storage Temperature(°C)	-20°C~60°C			
Storage Humidity	10%~90% (non-condensing)			
Certification	CE/FCC Class B			
Operating System Support	Windows Embedded Standard 7, Windows 7 Pro for Embedded			

Heavy-Duty Industrial Panel PC

Dimensions

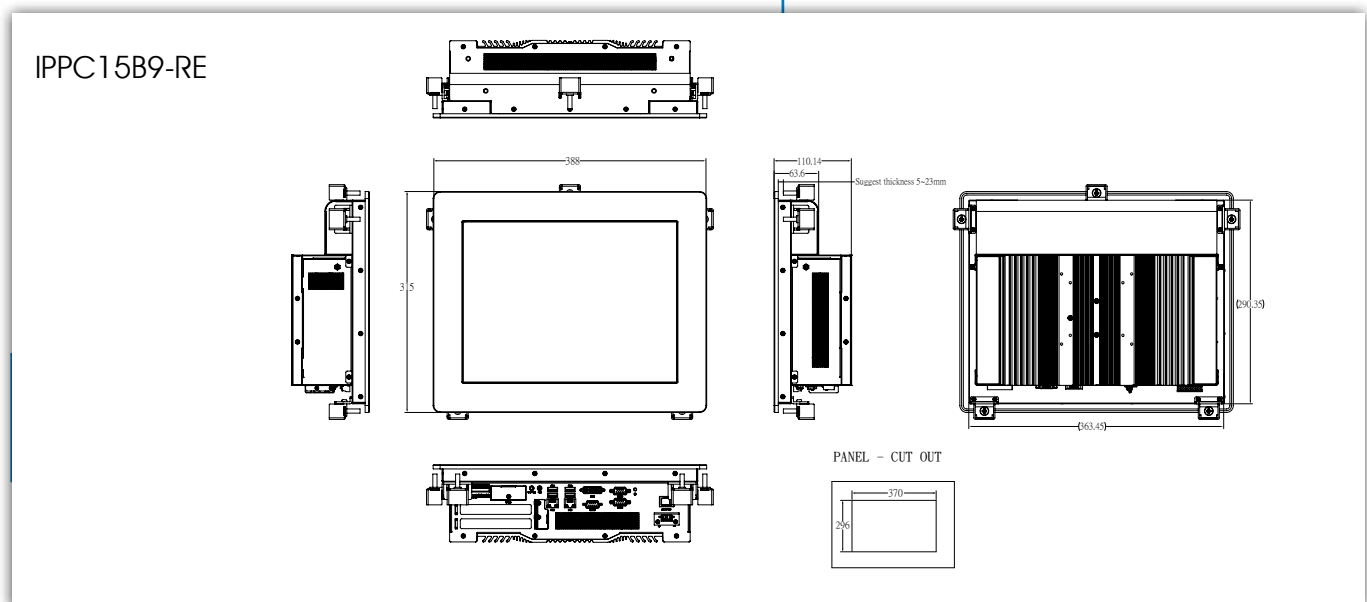
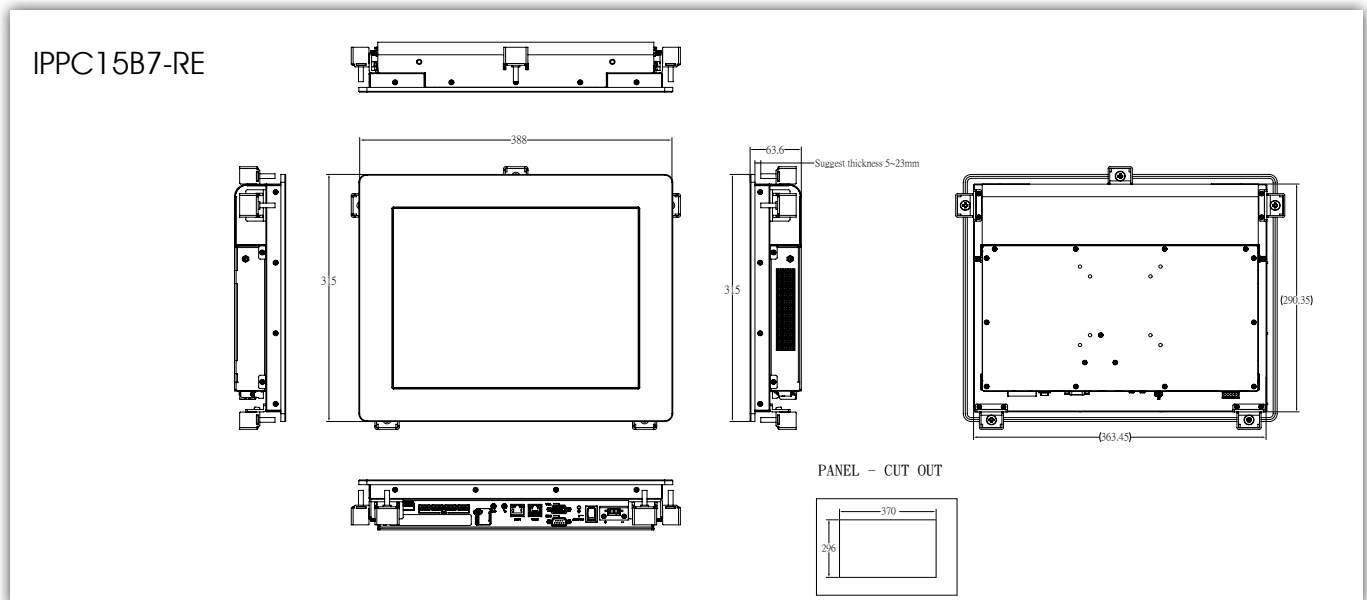

Ordering Information

IPPC15B7-RE	15" Modularized Panel PC, Intel® Atom™ D2550 1.86GHz, with 2GB DDR3 SO-DIMM, 320GB HDD, 9~32V DC, and resistive touch, w/o power adaptor
IPPC15B9-RE	15" Modular Panel PC with resistive touch Intel® Core™ i3-2340UE 1.3GHz CPU, 4GB DDR3-1333 SO-DIMM, 320G HDD, 12~24V wide range DC input, w/o power adaptor
Power adaptor	AC 90~240V input, 12V DC output 84W power adaptor IBASE P/N: A005PS084W0050000P

Heavy-Duty Industrial Panel PC

IPPC17B9-RE

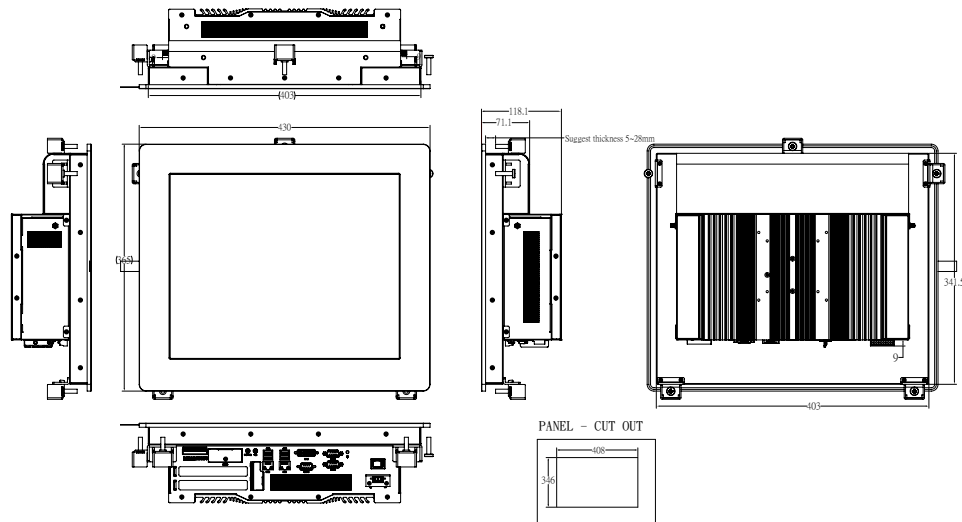

IPPC19B9-RE

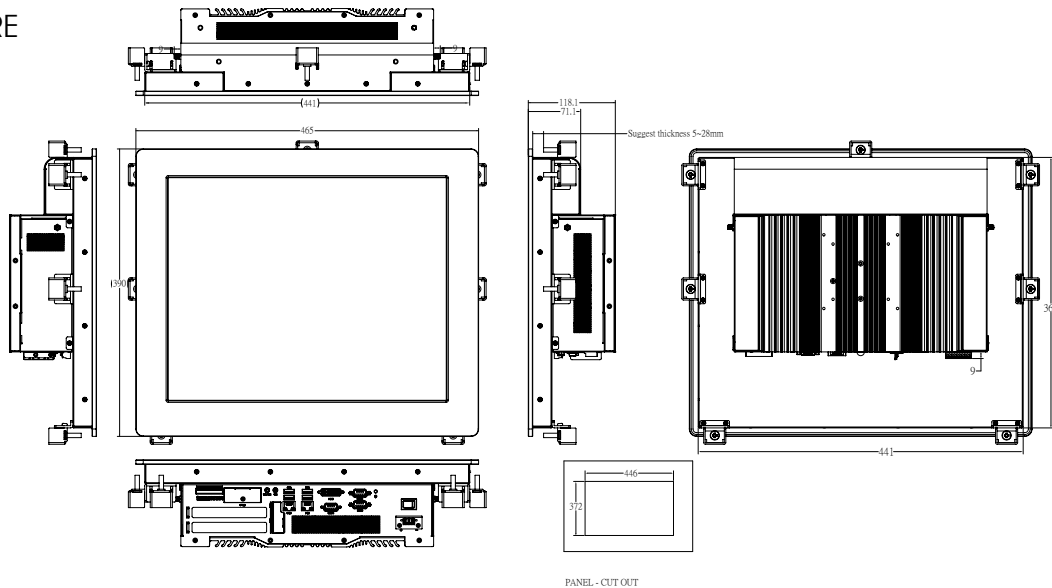

Ordering Information

IPPC17B9-RE	17" Modular Panel PC with resistive touch Intel® Core™ i3-2340UE 1.3GHz CPU, 4GB DDR3-1333 SO-DIMM, 320G HDD, 12V-24V wide range DC input, w/o power adaptor
IPPC19B9-RE	19" Modular Panel PC with resistive touch Intel® Core™ i3-2340UE 1.3GHz CPU, 4GB DDR3-1333 SO-DIMM, 320G HDD, 12V-24V wide range DC input, w/o power adaptor
Power adaptor	AC 90~240V input, 12V DC output 84W power adaptor IBASE P/N: A005PS084W0050000P