

Keysight Technologies

Becoming Familiar with your Standard Oscilloscope Probe

Application Note



Unlocking Measurement Insights

An often overlooked, important part of oscilloscope testing is the probe you use. The main role of a probe is to connect your target device under test (DUT) to the oscilloscope's input so you can pick up the signal from the DUT and view the waveform on the oscilloscope screen.

But keep in mind that an oscilloscope probe is not just a piece of wire with pointy tip attached to it. There is more to it that you need to know if you want correct testing results. The majority of oscilloscopes with ≤ 1 GHz bandwidth come standard with one high-impedance passive probe per each oscilloscope channel. This is the probe the majority of people will use.

The probe tip resistance is typically $9\text{ M}\Omega$ and will form a 10:1 resistor divider ratio with the $1\text{ M}\Omega$ oscilloscope input. The input signal to the probe is attenuated by a factor of $1\text{ M}\Omega / (9\text{ M}\Omega + 1\text{ M}\Omega)$. For instance, if you probed a 10 V signal with a probe including a 10:1 attenuation ratio, you should have a 1 V signal coming from the probe that is fed to the oscilloscope's input. The probe tip is followed by a high-impedance cable. A termination box or interface box at the end of the probe cable connects to the input of the oscilloscope.

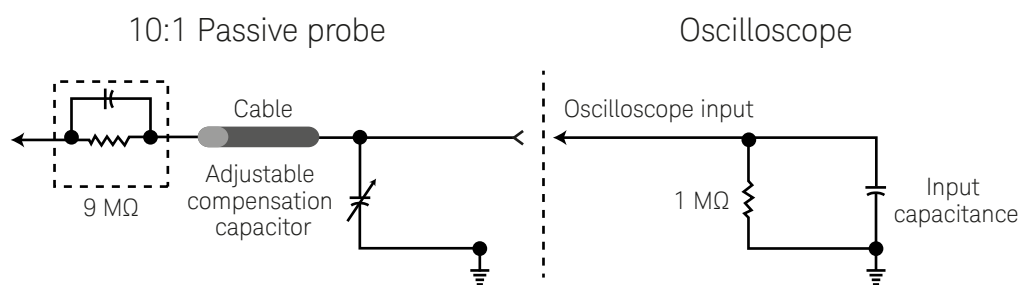

Figure 1. A simplified diagram of a high impedance passive probe with 10:1 attenuation ratio.

The primary feature of this probe is its very high impedance. At DC, the probe's input impedance has $10\text{ M}\Omega$ of resistance, and as the frequency goes up, the input impedance of the probe falls off as the capacitive reactance of the probe gets larger.

The standard passive probe is the most rugged, flexible and inexpensive probe that also gives a very wide input dynamic range – making this probe an excellent choice for general-purpose probing and troubleshooting.

Probe Compensation

Most standard passive probes have an adjustable compensation capacitor for matching RC coefficient to the input capacitance of the oscilloscope. The probe's adjustable compensation capacitor can be adjusted to cancel the input capacitance of the oscilloscope. To compensate the probe, the oscilloscope probe is connected to the probe compensation terminal to make the square wave look as square and flat-topped as possible. Before making any oscilloscope measurements, you should connect your probes to the probe compensation signal on the front panel to ensure they are properly adjusted.

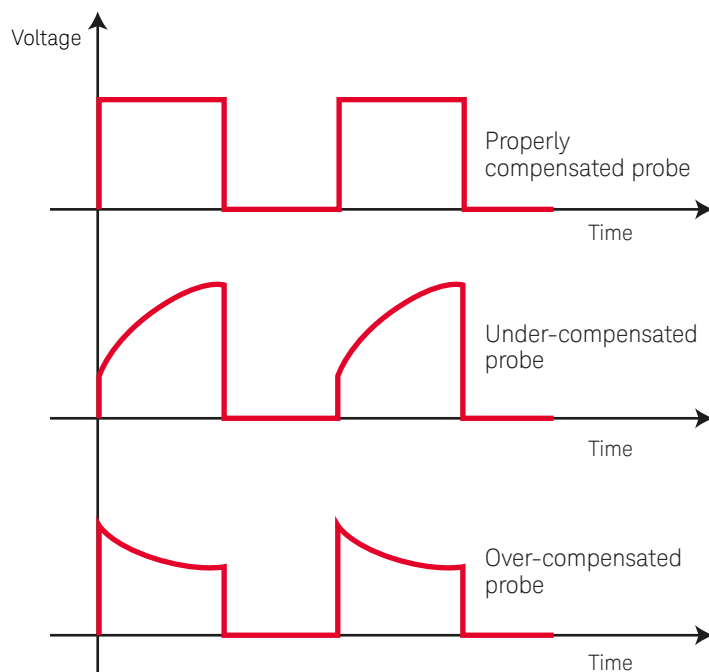

Figure 2. It's good practice to connect your probes to the probe compensation signal on the oscilloscope's front panel to ensure they are properly adjusted.

Dual Attenuation Ratio Probe

Most standard passive probes offer a 10:1 attenuation ratio. A standard passive probe usually provides a dual attenuation ratio – user selectable 10:1 and 1:1 range. The 1:1/10:1 probe has a switch that inserts what's usually a 9 M Ω resistor in series with the signal. In the oscilloscope, there's a 1 M Ω resistor for forming 10:1 input attenuation ratio. In the 1:1 mode, there is no series resistor on the probe side and the total DC resistance seen from the probe tip is only 1 M Ω on the oscilloscope's input.



Figure 3. Keysight's N2140A and N2142A dual-attenuation ratio passive probes which provide the convenience of having both 10:1 and 1:1 attenuation.

The primary benefit of using a dual-attenuation ratio probe is it provides the convenience of both 10:1 and 1:1 attenuation. In general, the 1:1 mode of the probe provides lower noise, making it ideal for measuring low level signals such as ripple and noise of a power supply. However, the 1:1 mode will produce a significant amount of capacitance appearing in parallel with the oscilloscope's input, resulting in reduction of the bandwidth down to approximately 25 MHz.

In the example below, a 10:1/1:1 probe is used to measure the power supply output noise with each attenuation ratio setting. At 1:1 mode, the measured noise is favorable with almost half the noise measured with the 10:1 mode.

Dual Attenuation Ratio Probe (Continued)

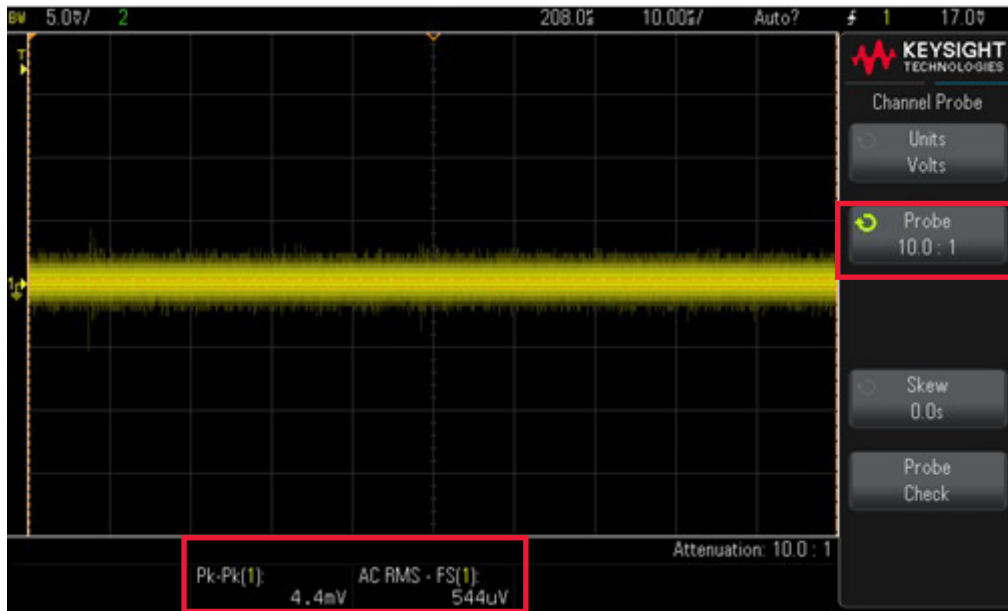

Figure 4. Oscilloscope and probe baseline noise with 10:1 probe.

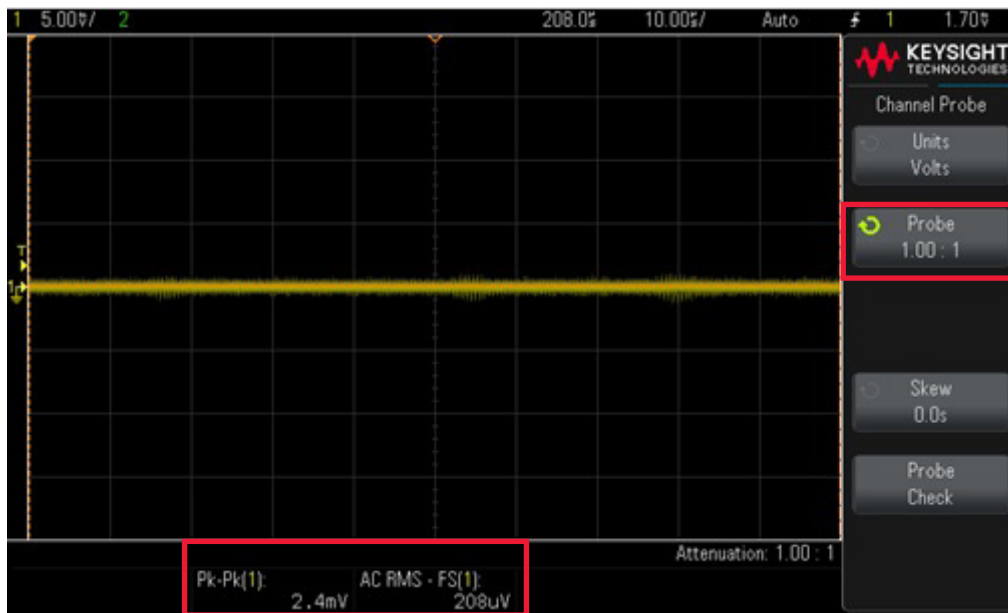

Figure 5. Oscilloscope and probe baseline noise with 1:1 probe.

Understanding Probe Loading

When you connect an oscilloscope probe to a circuit, the probe becomes part of the circuit-under-test and the probe's electrical characteristics affect the overall measurement response. These effects can degrade measurement accuracy and operation because the new circuit that includes the probe will behave differently from the circuit without the probe. This is especially true when testing higher frequency signals.

All probes present resistive, capacitive and inductive loading. The challenge is to ensure these effects stay within acceptable limits. Resistive loading is usually the least worrisome of the three loading effects, as long as you're using a high impedance passive probe for measuring low speed signals. The most common resistive loading effect results from the voltage divider consisting of the circuit's output resistance and the probe's input resistance.

$$V_{in} = V_{source} \times \frac{Z_{probe}}{Z_{source} + Z_{probe}}$$

Z_{source} is the source impedance of the circuit-under-test. The lower the probe's resistance relative to Z_{source} , the more the probe-loading reduces the measured waveform's amplitude. For instance, if Z_{source} is 1 M Ω and Z_{probe} is 10 M Ω , the measured amplitude is roughly 9% less than the actual value before the signal is probed.

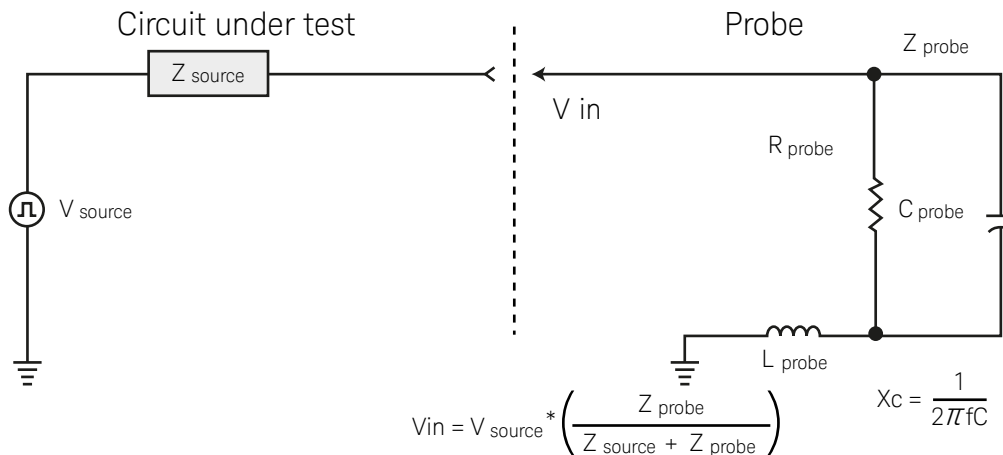

Figure 6. The probe's resistive, capacitive and inductive components can change the response of the circuit under test, depending on how much the probe loads the circuit.

Understanding Probe Loading (Continued)

At DC, the probe's resistance determines its input impedance and loading characteristics. While the probe's capacitive reactance does not contribute to the measurement as the capacitance reactance (X_c) is infinite at DC. However, as the frequency increases the capacitive reactance gets smaller and becomes the major source of loading, drawing more and more energy from the circuit under test.

If you took a measurement of your target, you might see a ringing of your waveform. Is that from your circuit or from probing? It's hard to decipher, but it's a valid question. Inductive loading often appears as ringing in the observed waveform. The source of the ringing is the LC resonance circuit, which comprises the probe's internal capacitance and ground lead and the probe tip inductance. The ringing frequency of a simple LC circuit is:

$$\text{Fringing} = 1 / 2\pi\sqrt{LC}$$

Where Fringing is the frequency in Hz, L is the inductance in Henry, and C is the capacitance in farad.

A ground lead is often a major source of inductive loading. Simply changing the alligator ground lead to a shorter one may change the waveform you are measuring. If this occurs, you probably have a problem with inductive loading, not with your circuit.

Conclusion

It's important to choose your probe wisely and use it in a way that ensures you're getting the most reliable measurements. Combining the right probe with the right oscilloscope puts you on the path to the most precise oscilloscope measurements. You learned the theory of passive probe operation as well as the benefit of compensating the probe before measurement. Dual-attenuation ratio probes provide the convenience of both 10:1 and 1:1 attenuation ratio in a single package. It is very important to understand the electrical behavior of the probe because it can affect the measurement results and the operation of the circuit.

Evolving Since 1939

Our unique combination of hardware, software, services, and people can help you reach your next breakthrough. We are unlocking the future of technology.

From Hewlett-Packard to Agilent to Keysight.

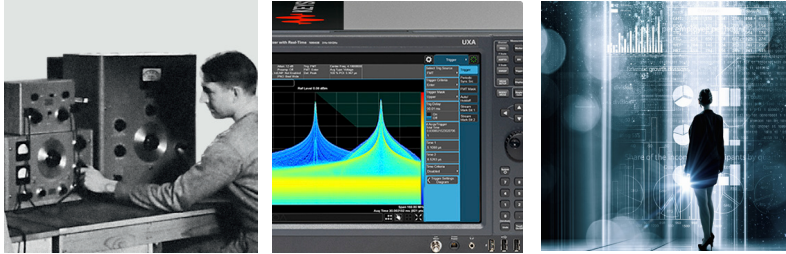

myKeysight

myKeysight

A personalized view into the information most relevant to you.

Register your products to get up-to-date product information and find warranty information.

KEYSIGHT SERVICES

Accelerate Technology Adoption.
Lower costs.

Keysight Services

Keysight Services can help from acquisition to renewal across your instrument's lifecycle. Our comprehensive service offerings—one-stop calibration, repair, asset management, technology refresh, consulting, training and more—helps you improve product quality and lower costs.



Keysight Assurance Plans

Up to ten years of protection and no budgetary surprises to ensure your instruments are operating to specification, so you can rely on accurate measurements.

Keysight Channel Partners

Get the best of both worlds: Keysight's measurement expertise and product breadth, combined with channel partner convenience.

